

STOP!

Don't Connect Unless You Inspect!

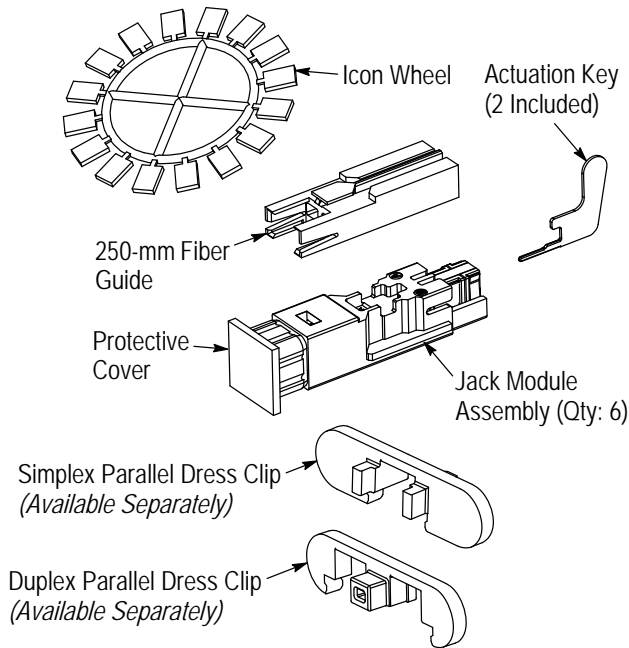

i **NOTE**
Dimensions in this instruction sheet are in metric units [with U.S. customary units in brackets]. Figures are not drawn to scale.

The jacks fit into adapter plates or patch panels for use in a rack- or wall-mount enclosures or enclosures having an adapter plate or patch panel. The jacks can also be installed in wall outlets for use in wall boxes using Parallel Dress Clip 1374206-1 (simplex) or 1374205-1 (duplex) shown in Figure 1.

i **NOTE**
For available adapter plates, patch panels, enclosures, and wall outlets, and installation instructions, refer to 408-8844.

Reasons for reissue of this instruction sheet are provided in Section 6, REVISION SUMMARY.

2. DESCRIPTION (See Figure 1)

Each jack kit contains six MT-RJ jack module assemblies (each with protective cover), an icon wheel, 250-mm fiber guide (beige), and two actuation keys.

i **NOTE**
The jack kits are shipped with the protective covers installed onto the jacks. Keep protective covers in place until ready for connection.

Each jack has two channels designated (on the top of the jack) with "A" and "B".

MT-RJ JACK KIT		OPTICAL FIBER SIZE*
PART NUMBER	DESCRIPTION	
6278303-1	Standard Jacks	50/125 μ m
6278807-[]	MT-RJ SECURE* Jacks	
6278303-2	Standard Jacks	62.5/125 μ m
6278808-[]	MT-RJ SECURE Jacks	
6278303-4	Standard Jacks	XG 50/125 μ m
6693951-[]	MT-RJ SECURE Jacks	

*The fiber optic size is marked on the rear underside of the jack module assembly. Size "50/125" is indicated as "50", Size "62.5/125" is indicated as "62", and Size "XG 50/125" is indicated as "XG".

Figure 1

1. INTRODUCTION

The MT-RJ jack kits listed in Figure 1 are designed to terminate 250-mm coated optical fiber. The jack kits must be used with only the optical fiber size given in Figure 1. Read these instructions thoroughly before assembling the jack kits.

i **NOTE**
These jack kits cannot be used with build-up tubes, loose tube fiber, easy-strip fiber, fan-out kits, or breakout kits.

3. ASSEMBLY PROCEDURE

! DANGER
ALWAYS wear eye protection when working with optical fibers. NEVER look into the end of terminated or unterminated fibers. Laser radiation is invisible but can damage eye tissue. NEVER eat, drink, or smoke when working with fibers. This could lead to ingestion of glass particles.

! CAUTION
During assembly, keep components and tools as clean as possible to avoid contamination in the optical interface.

3.1. Tools and Materials

The following tools and materials are necessary for preparation, assembly, inspection, and maintenance of the assembly. Follow the operating instructions (408-series) packaged with the tools and safety guidelines packaged with the materials.

A. Required

- Fiber Optic Combination Strip Tool 1278947-1 (408-4577) or 1754708-1
- Alcohol Fiber Wipe Packet 501857-2 or lint-free tissues and isopropyl alcohol greater than 91% (99% preferred)
- Fiber Optic Cleaver 1871696-1 (408-10086)



NOTE

The above items are included in MT-RJ Jack Termination Kit 1278346-1 and LightCrimp Plus* and MT-RJ Jack Combination Termination Kit 1278118-4.

- Canned air (commercially available)
- Test Kit (408-4579):

TEST KIT	OPTICAL FIBER SIZE (Multimode)	TEST EQUIPMENT CONNECTOR INTERFACE
1278861-1	50/125- μ m	SC
1278861-2		Straight Tip (ST) Style
1278862-1	62.5/125- μ m	SC
1278862-2		ST Style

B. Optional

- Visual Fault Locator 1828352-1
- Bare Fiber Adapter 934-125 (available from RIFCOS)
- 200 Microscope Kit 1754767-1
- 2.5mm Universal Adapter 1754766-1 (included with microscope)
- MT-RJ Microscope Adapter 1754768-1 (use with microscope)

3.2. Preparation

A. Stripping the Cable

IMPORTANT - For correct system polarity, Channel “A” must be connected to Channel “B” and Channel “B” must be connected to Channel “A” on any cable run or cable assembly (including fiber optic equipment). Refer to Figure 2.

1. Using the fiber optic combination strip tool, strip the fiber to 31 to 33 mm [1.22 to 1.30 in.].
2. Clean the stripped portion of the fiber with an alcohol fiber wipe or lint-free tissue moistened with isopropyl alcohol greater than 91% (99% preferred) to remove the fiber coating residue. DO NOT touch the stripped portion of the fiber after cleaning.

RIFCOS is a trademark

Panel Workstation

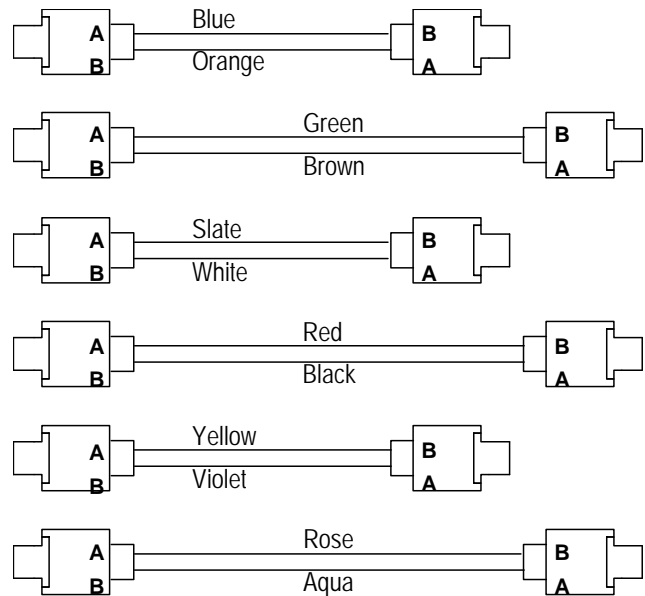

Figure 2

B. Cleaving the Fiber



CAUTION

Fibers must be terminated as soon as the cleaving and inspection process is complete; otherwise, damage to the fibers could result.

1. Open the fiber clamp of the fiber optic cleaver. Press the button, and slide the carriage back (toward the fiber clamp). Then move the fiber slide back until it stops.
2. Place the stripped fiber into the slot so that the end of the buffer is at the 4-mm marking. See Figure 3, Detail A.
3. While applying pressure on the buffer, carefully slide the fiber slide forward (toward the carriage) until it stops. See Figure 3, Detail B.
4. Gently close the fiber clamp, and slide the carriage forward. DO NOT touch the button while sliding the carriage. See Figure 3, Detail C.
5. Open the fiber clamp, and move the fiber slide back until it stops.
6. Remove the cleaved fiber, and properly dispose of the scrap fiber. If the fiber does not cleave, repeat the process starting with Step 3 of Paragraph 3.2.A.



CAUTION

Be careful to dispose of fiber ends properly. The fibers create slivers that can easily puncture skin and cause irritation.



CAUTION

DO NOT attempt to clean the fiber after it has been cleaved.

Detail A

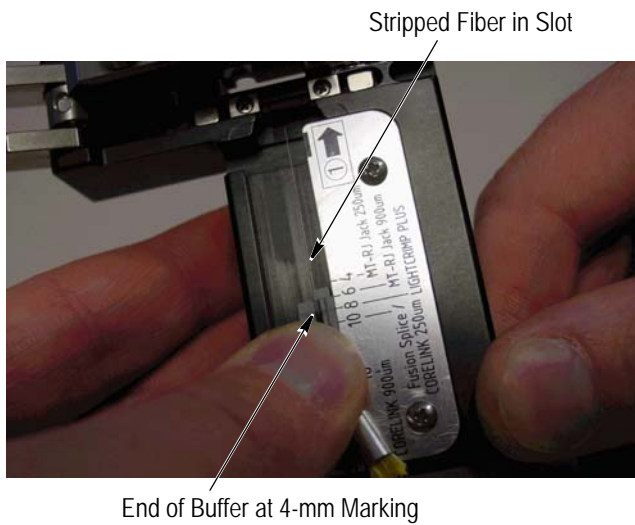

1. Fit the bare fiber adapter onto the universal adapter; then assemble the universal adapter onto the microscope.

2. Using the microscope, inspect the fiber for a quality cleave. Refer to the instructions packaged with the microscope kit) for operating procedures and safety precautions concerning the microscope.

IMPORTANT - Fibers must be terminated as soon as the cleaving and inspection process is complete; otherwise, damage to the fibers could result. Proceed to Paragraph 3.3.

3.3. Termination

i **NOTE**
DO NOT use build-up tubes, loose tube fiber, easy-strip fiber, fan-out kits, or breakout kits.

IMPORTANT - For correct system polarity, Channel "A" must be connected to Channel "B" and Channel "B" must be connected to Channel "A" on any cable run or cable assembly (including fiber optic equipment). Refer to Figure 2.

Proceed as follows:

1. Holding the jack or placing the jack on a clean, flat surface (the protective cover helps to keep the jack stabilized), slide the fiber guide onto the back of the jack. See Figure 4.

i **NOTE**
The fiber guide is marked with the fiber size. Make sure that the marking on the fiber guide corresponds with the fiber size being used.

Detail B

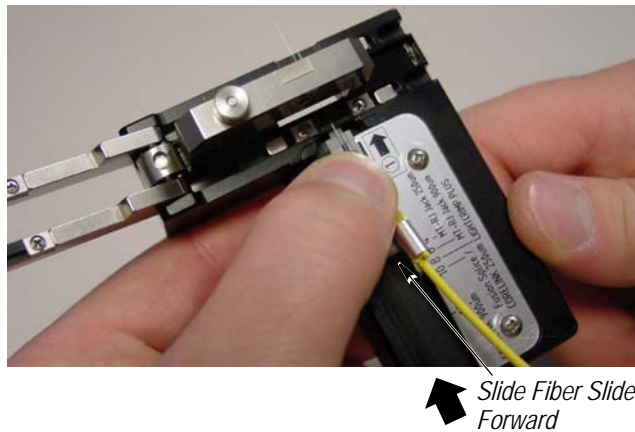

Detail C

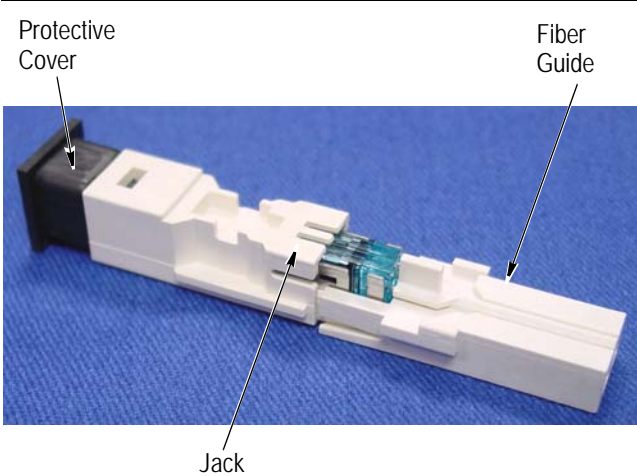
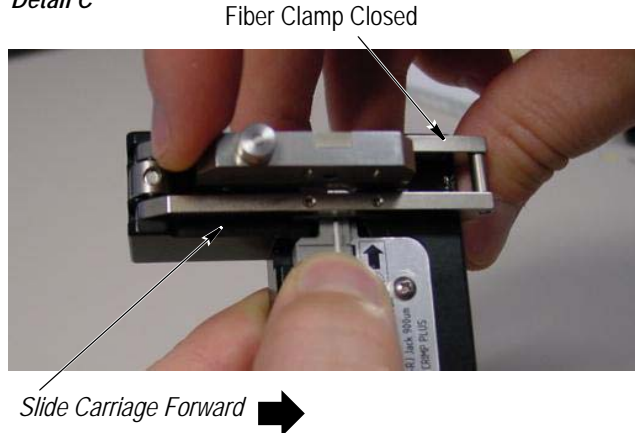

Figure 3

Figure 4

! **CAUTION**
Fibers must have a quality cleave before terminating to the jacks. To ensure that the cleave tool is producing quality cleaves, it is **STRONGLY RECOMMENDED** to inspect at least one fiber cleave per day according to the following:

2. With the handle of the actuation key pointing toward the top of the jack, insert the key (pointed end first) into the key hole for Channel A until it stops (the entire key portion must be inside the hole). See Figure 5, Detail A. DO NOT force the key. With the key in this position, the fiber hole is "closed".

3. Slide the prepared fiber onto the slot on the fiber guide and into the fiber hole until the fiber stops. See Figure 5, Detail A.

4. While lightly holding the fiber in place, SLOWLY rotate the key handle 90° (one-quarter turn) toward the outside of the jack. See Figure 5, Detail B. With the key in this position, the fiber hole is “open”.



CAUTION

Ensure that the key is rotated *ONLY* one-quarter turn; otherwise, the fiber hole will be partially open, and the fiber cannot be inserted.

5. Insert the fiber further into the fiber hole until it bottoms. See Figure 6, Detail A. If the fiber stubs while inserting it into the fiber hole, slightly turn the fiber, and continue to insert the fiber into the hole. The fiber is fully inserted into the fiber hole when the stripped portion of the fiber is inside the jack.

6. Hold the fiber in place using enough pressure to create a slight bow in the fiber, then SLOWLY rotate the key handle 90° (one-quarter turn) toward the inside of the jack. DO NOT “flip” the key handle. Refer to Figure 6, Detail B. The fiber is now terminated to the jack.

7. Remove the key from the jack.



NOTE

If preferred, use the visual fault locator to confirm that the fiber is fully inserted into the fiber hole. When the fiber is properly inserted, the laser (or LED) light will diminish in the target area of the jack. Refer to Figure 7.



CAUTION

If using the visual fault locator, avoid contamination to the ferrule end face. Make sure that the protective cover remains clean when removed, and then before proceeding, that the protective cover is re-installed onto the jack.



NOTE

If the ferrule end face is touched or otherwise contaminated, clean the end face with canned air before re-installing the protective cover. TO AVOID PERSONAL INJURY, wear eye protection.

8. Repeat the assembly procedure for Channel B.

9. Carefully slide the fiber guide at least 76 mm [3 in.] away from the jack, then carefully route the fiber out of the slot in the fiber guide. Keep the protective cover on the jack if not installing the jack immediately.

Detail A

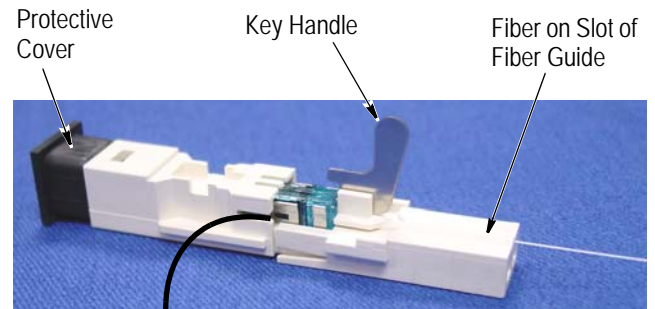
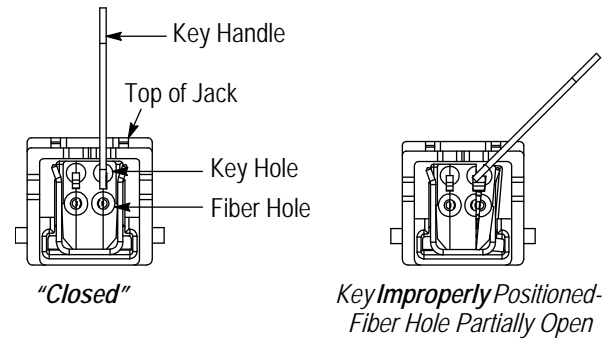

Detail

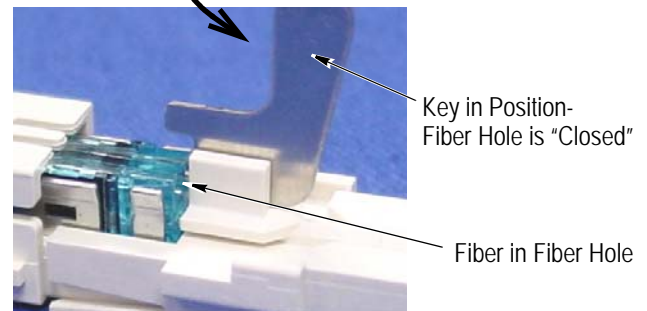

Detail B

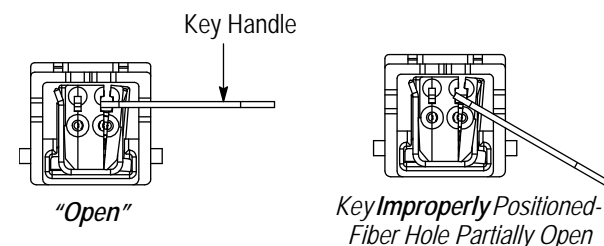
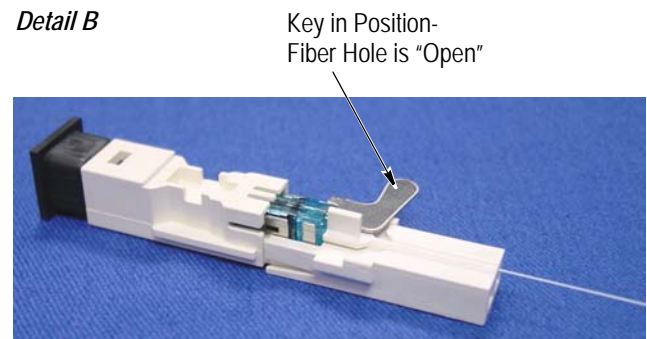
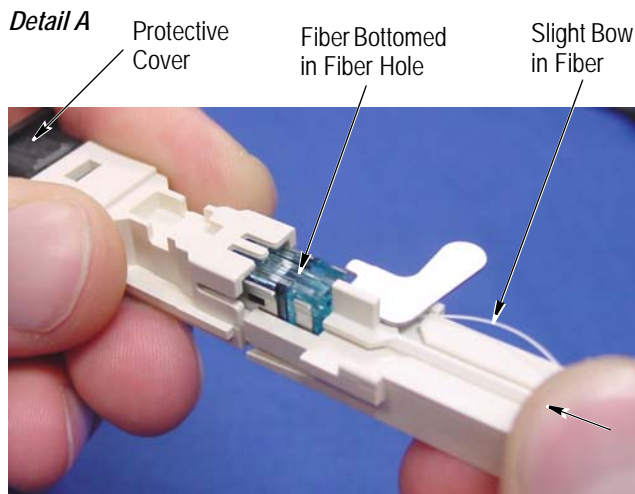

Figure 5



Insert Fiber into Fiber Hole

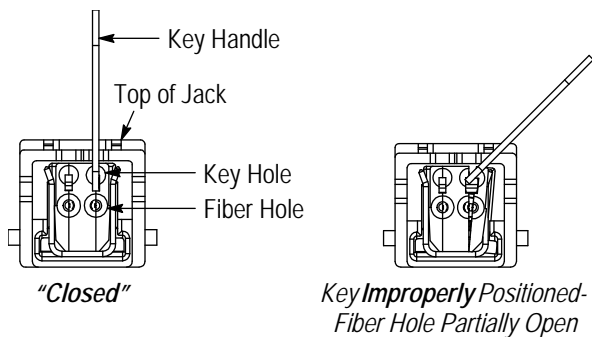
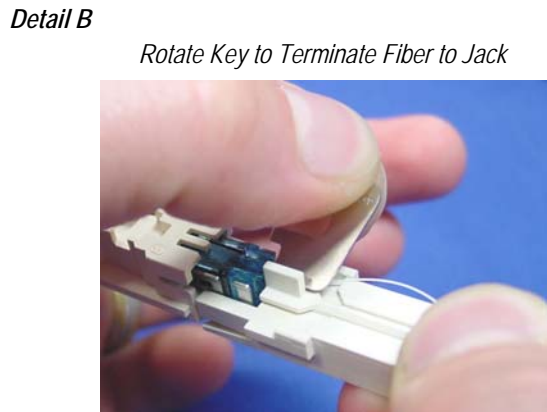

Figure 6

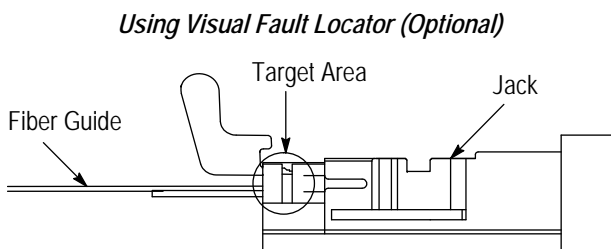

Figure 7



CAUTION

To avoid putting tension on the fiber, it is important to slide the fiber guide away from the jack before routing the fiber out of the fiber guide.

3.4. Inspection

Remove the protective cover, and inspect the ferrule end face for cleanliness using the microscope kit.

STOP!
Don't Connect Unless You Inspect!

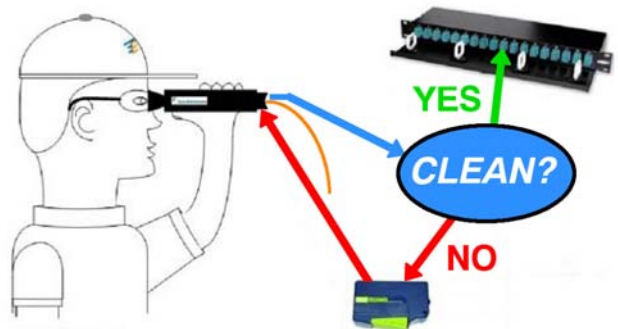

DANGER: Never View Active Fiber Signals

3.5. Installation

Refer to Instruction Sheet 408-8844 for instructions on installing the jacks into the adapter plates, patch panels, or enclosure or wall outlets.

4. TESTING

Test the system attenuation and polarity using the applicable test kit listed in Paragraph 3.1.A. Refer to 408-4579 (packaged with the test kit) for instructions on using the test kit and testing procedures.

5. REPLACEMENT AND REPAIR

Jack kit components are not repairable. Replace any damaged or defective components. DO NOT re-use the jacks by removing the fibers after a successful termination.

6. REVISION SUMMARY

Revisions to this instruction sheet include:

- Updated document to corporate requirements
- New logo