

AMPAMP INCORPORATED
HARRISBURG, PA 17105CUSTOMER HOTLINE
1 800 722-1111AMP* SMB MIL-TYPE 50-OHM AND 50- AND
75-OHM COMMERCIAL PRINTED CIRCUIT
BOARD (PCB) RIGHT-ANGLE JACK CONNECTORS**IS 2987-10**RELEASED
10-23-91**MIL-TYPE 50-OHM RIGHT-ANGLE JACK CONNECTOR
414026 (Ref)**

Fig. 1

cad

1. INTRODUCTION

This Instruction Sheet (IS) covers the installation of AMP SMB MIL-Type 50-Ohm and 50- and 75-Ohm PCB Commercial Connectors (such as 413996, 414026, 228435, and 221014) designed for right-angle mount applications.

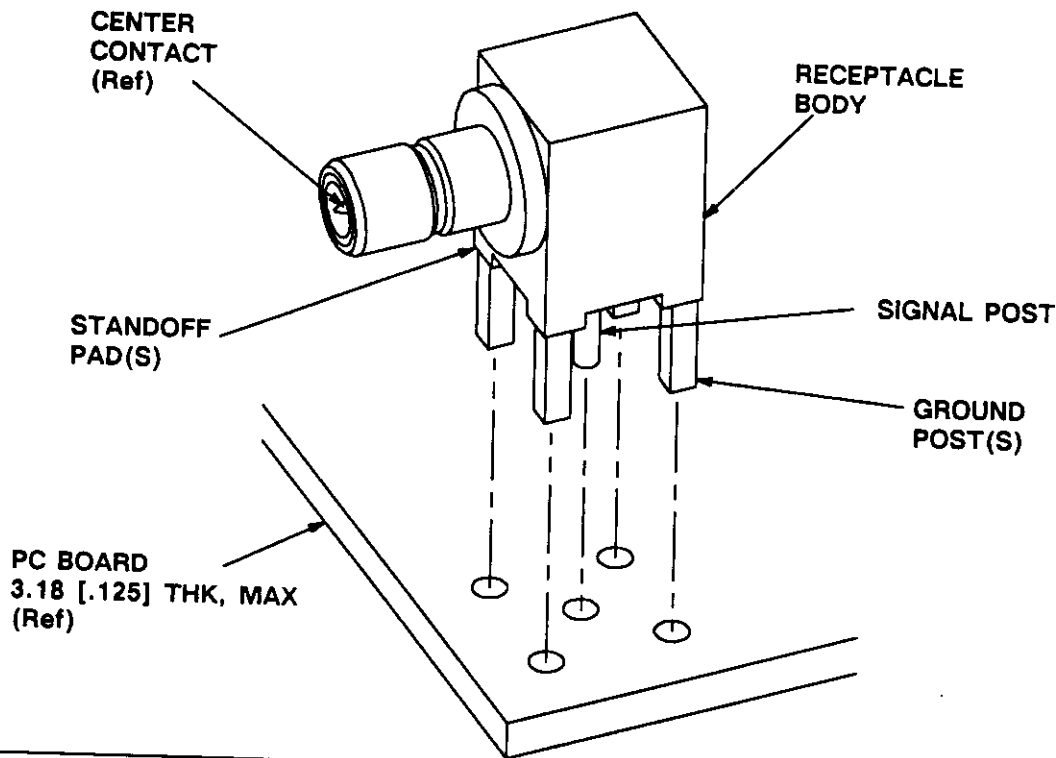
Read this instruction sheet thoroughly before starting assembly.

NOTE

Dimensions on this instruction sheet are in millimeters followed by inches in brackets.

2. DESCRIPTION

The right-angle connectors are designed with a receptacle body with four ground posts and four standoff pads (with the exception of MIL-Type 50-Ohm connector 413996, which is designed without standoff pads), and a signal post. The connectors can be

mounted from the center to the outer edge of a 3.18 [.125] thick (maximum) pc board.

3. MOUNTING CONNECTORS

1. Determine location for connector on pc board.
2. Make a layout on the pc board using the appropriate dimensions provided in Figure 2.
3. Insert the ground posts into the pc board until the standoff pads are seated on the pc board. See Figure 3, A.

NOTE

Since there are no standoff pads on MIL-Type 50-Ohm right-angle jack connector 413996, the receptacle body must be seated on the pc board, as shown in Figure 3, B.

4. Solder connector to pc board, making sure it remains seated. Use standard soldering techniques. Remove any flux residue.

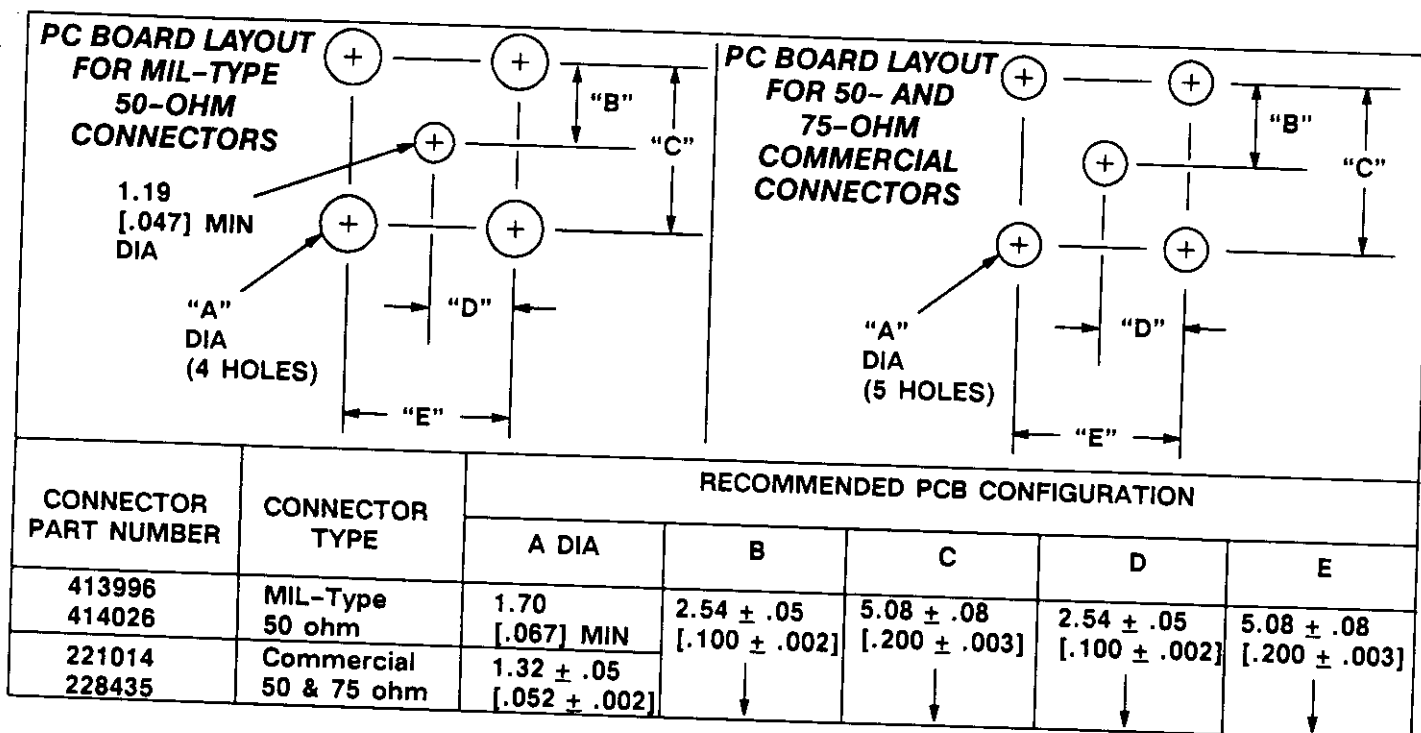

Fig. 2

cad

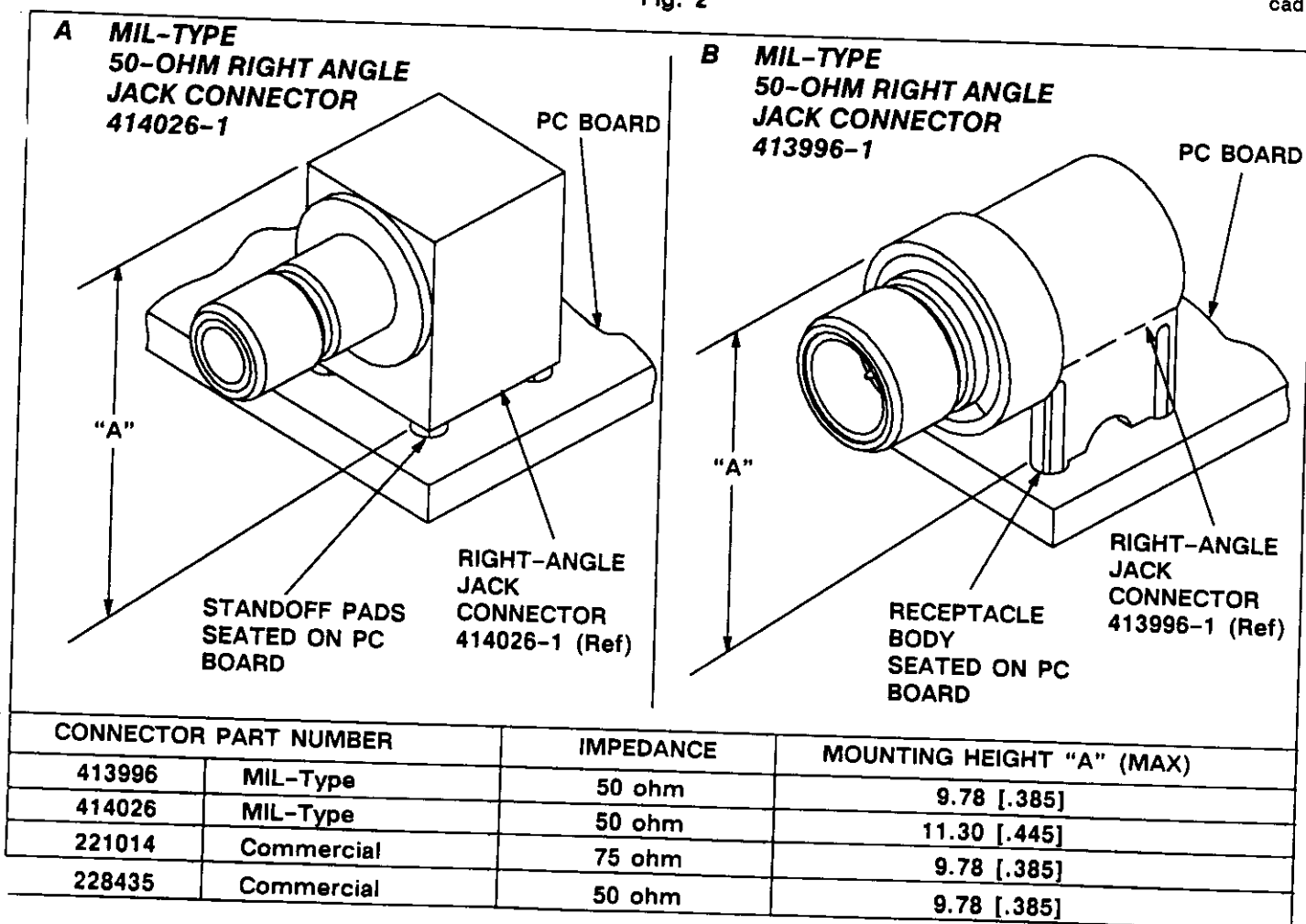

Fig. 3

cad