

1. INTRODUCTION

This publication provides "Instructions" on product application and a "Maintenance and Inspection Procedure" for:

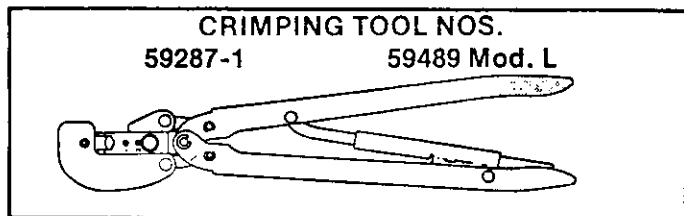

These tools are used to crimp:

- PLASTI-GRIP★ butt splices on wire sizes 12 thru 10.

Basic instructions on the use of these tools, wire preparation, tool adjustments, etc. are provided in Section 2, "Instructions." Section 3 features a splice "Crimp Inspection" procedure. Section 4 contains a "Maintenance and Inspection Procedure" which will enable you to establish and maintain a *tool certification program*.

These instructions may be used for tools not listed in Figure 1 but accompanied by this IS. for unlisted tools, use the wire strip dimensions given in Figure 1 for an identical size tool.

Tools are coated with preservative to prevent rust and corrosion. Wipe this preservative from tool, particularly from crimping area.

2. INSTRUCTIONS

NOTE: Refer to paragraph 2.3 for insulation crimp adjustment.

2.1 WIRE STRIPPING

Strip wire to dimensions listed in Figure 1.

NOTE: Do not use wire with nicked or missing conductor strands.

2.2 CRIMPING PROCEDURES

Open crimping dies by closing handles until CERTI-CRIMP★ ratchet, see Figure 3, releases. Note that once ratchet is engaged handles cannot be opened until they are first fully closed.

- Note that the splices and tool handle are color coded yellow. See Figure 1.
- Place splice in crimping dies so that end of splice butts against locator as shown in Figure 2.
- Close handles until splice is held firmly in place. Do not deform splice barrel.
- Insert stripped wire until end of conductor butts against splice wire stop. See Figure 2.
- Close tool handles until ratchet releases.
- To crimp other half of splice, turn splice or tool around. Position uncrimped half in dies and follow same procedure used to crimp first half of splice.
- Observe dot code on finished crimp to insure that correct splice and tool combination was used. See Figure 1.

TOOL NO. & COLOR CODE	SPLICE WIRE RANGE	MAX. INSUL. DIA.	SPLICE INSULATION COLOR AND DOT CODE	WIRE STRIP LENGTH	
				MIN.	MAX.
59489 MOD. L YELLOW	12-10	.250	YELLOW 1 DOT	9/32"	5/16"
59287-1 YELLOW	12-10 LG. EXP.	.300		5/16"	11/32"

Figure 1

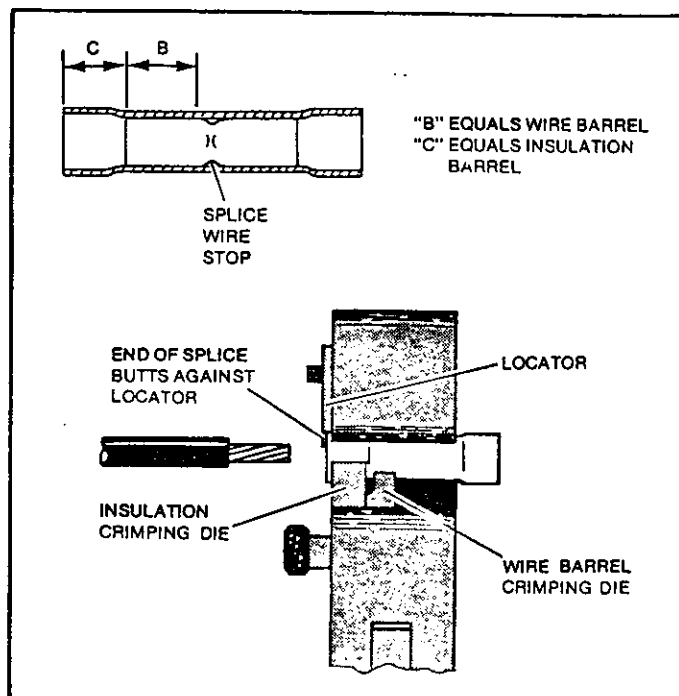

Figure 2

- Refer to paragraph 3 and Figure 4 for splice crimp inspection procedure.

2.3 INSULATION CRIMPING ADJUSTMENT

NOTE: PLASTI-GRIP splices feature a wire insulation support only.

The insulation crimping section of the hand tool has three positions: 1 — Tight, 2 — Medium, 3 — Loose. See Figure 3.

- Position No. 3 is for wire having a large insulation diameter.
- Position No. 2 is for wire having a medium insulation diameter.

All illustrations and information contained in this instruction sheet are based on the latest product information available at the time of publication.

Copyright 1960, 1965, 1979 by AMP Incorporated, Harrisburg, Pa. All International Rights Reserved. AMP Incorporated products covered by U.S. and Foreign Patents and/or Patents Pending.

- (c) Position No. 1 is for wire having a small insulation diameter.

Splice insulation should ideally be in contact with wire insulation after crimping.

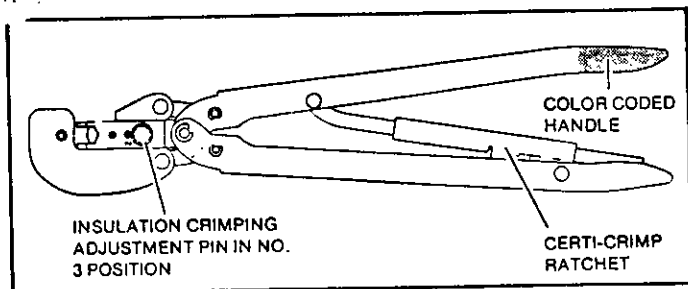

Figure 3

3. CRIMP INSPECTION

Inspect crimped splices by checking the features described in Figure 4.

Use only the splices that meet the conditions shown in the "ACCEPT" column.

"REJECT" splices can be avoided through careful use of instructions in Section 2, and by performing regular tool maintenance as instructed in Section 4.

4. MAINTENANCE/INSPECTION PROCEDURE

AMP recommends that a maintenance/inspection program be performed periodically to ensure dependable and uniform terminations. Tools should be inspected at least once a month. Frequency of inspection may be adjusted to suit your require-

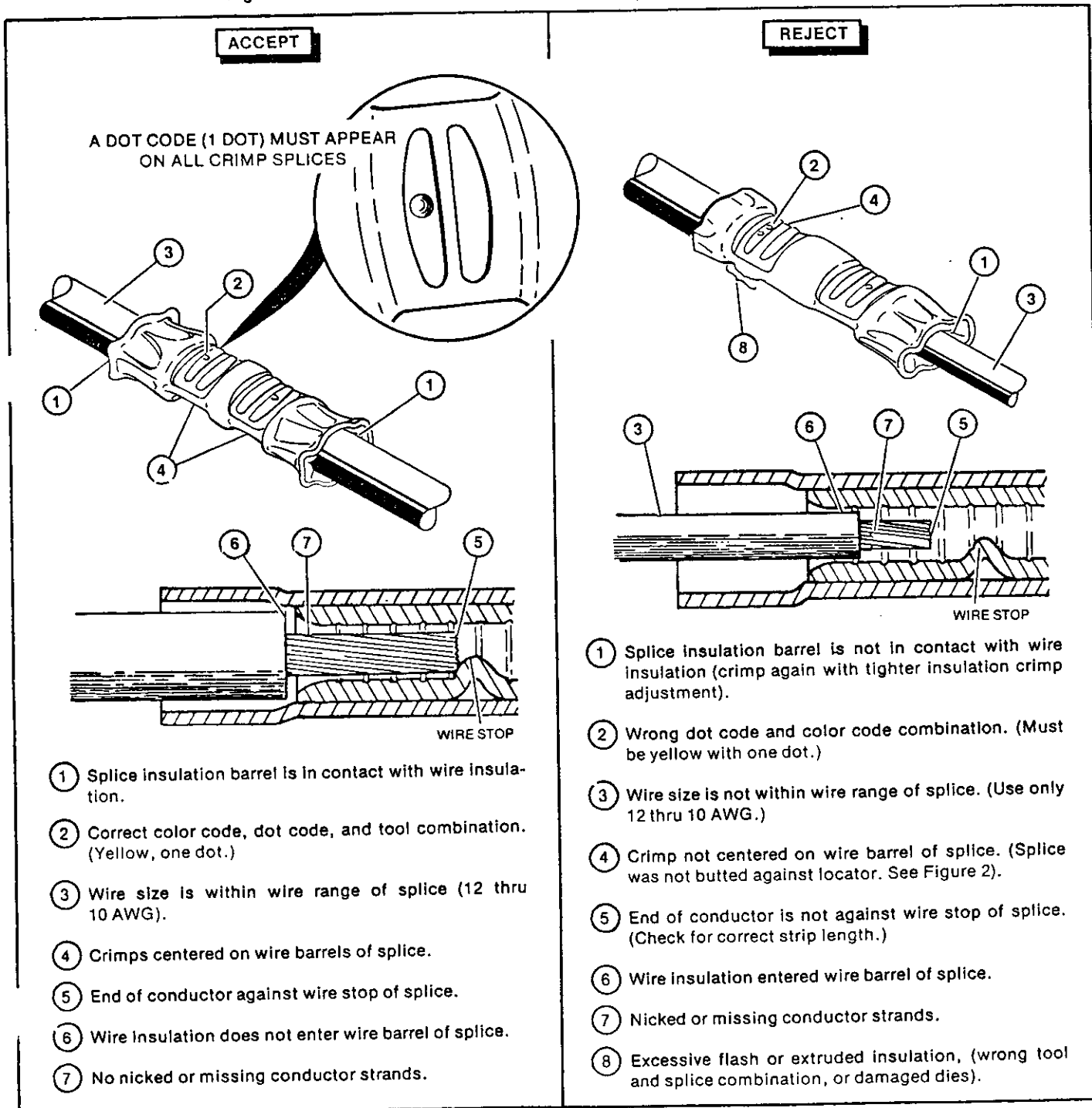

Figure 4

ments through experience. Frequency of inspection is dependent upon:

1. The care, amount of use, and handling of the tool.
2. The type and size of the products crimped.
3. The degree of operator skill.
4. The presence of abnormal amounts of dust and dirt.
5. Your own established standards.

All tools are inspected before packaging. Since there is a possibility of tool damage in shipment, new tools should be inspected in accordance with Section 4 when received in your plant. Due to the precision design, *it is important that no parts of these tools be interchanged except those replacement parts listed in Figure 9.*

4.1 CLEANING

The tool should be immersed (handles partially closed) in degreasing compound to remove accumulated dirt, grease and foreign matter. Make certain the degreasing compound does not attack paint or plastic materials.

Remove remaining degreasing compound with a lint free cloth. When degreasing compounds are not available, tool may be wiped clean with a lint free cloth. Relubricate tool, as instructed in paragraph 4.3 before placing it back in service.

4.2 VISUAL INSPECTION

- (a) Visually inspect the tool for missing pins or retaining rings. If parts are missing or defective, refer to Figure 9 for customer replaceable parts.
- (b) Visually inspect the die closure surfaces for flattened, broken or chipped conditions. Although dies may gage within permissible limits, worn or damaged die closure surfaces are objectionable and can affect the quality of the crimp. Examples of possible damaged die closure surfaces are shown in Figure 5.

4.3 LUBRICATION

Lubricate all pins, pivot points and bearing surfaces with a good grade S.A.E. #20 motor oil as follows:

Tools used in daily production — Lubricate daily
 Tools used daily (occasional) — Lubricate weekly
 Tools used weekly — Lubricate monthly

Wipe excess oil from tool, particularly from crimping area. Oil transferred from crimping area onto certain terminations may affect the electrical characteristics of an application.

4.4 DIE CLOSURE INSPECTION

Each tool is inspected for proper die closure before packaging. An inspection should be performed periodically to check the tool die closure for excessive wear.

NOTE: *The following plug gaging information for insulation crimp die closures is provided for customers specifically requiring this information. If plug gaging is not required, inspect the die closures using an alternate procedure, i.e., performing the "Insulation Crimp Adjustment" (see para. 2.3) and "Visual Inspection" (see para. 4.2).*

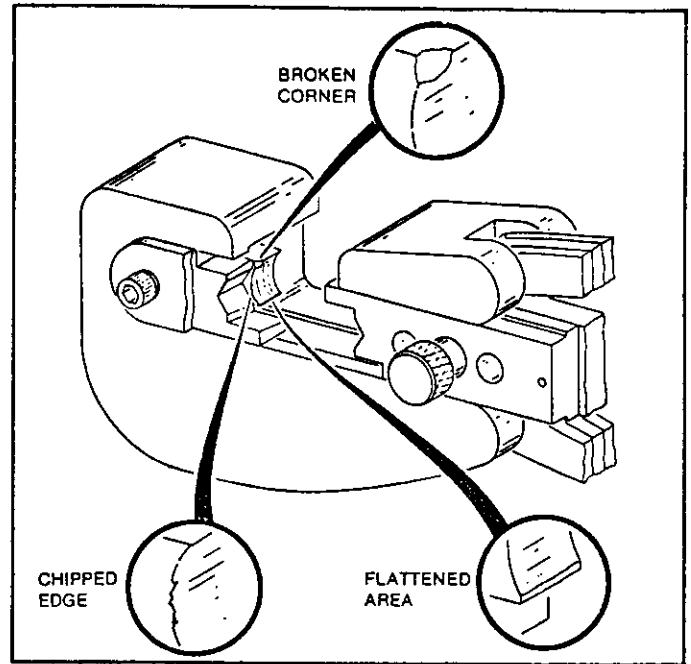

Figure 5

The die closure inspection is accomplished using GO NO-GO plug gages. AMP neither manufactures nor sells plug gages. Suggested designs and GO NO-GO dimensions for the plug gage members are listed in Figures 6 and 7. The following procedure is recommended for inspecting the die closures.

- (a) Clean oil or dirt from the die closures and plug gage members.
- (b) Close handles of tool until wire barrel dies are bottomed. Do not apply additional pressure to tool handles.
- (c) With wire barrel dies bottomed, inspect the wire barrel crimp die closure using the proper plug gage. Carefully try to insert, without forcing, the GO member. See Figure 8, Detail A. The GO member must pass completely through the die closure.
- (d) Try to insert the NO-GO member. The NO-GO member may enter partially, but must not pass completely through the die closure.
- (e) Insert insulation crimp adjustment pin in the No. 1 position.
- (f) On tool No. 59489 Mod. L, loosen socket head screw in locator. Swing locator 90° and re-tighten socket head screw. See Figure 8, Detail B.
- (g) Measure the insulation crimping die closure using the proper plug gage in the same manner as steps (c) thru (d). See Figure 8, Detail B.
- (h) On tool No. 59287-1, measure the insulation crimping die closure using the proper plug gage. Hold gage in approximately a 45° angle with the die closure and carefully try to insert, without forcing, the GO member. See Figure 8., Detail B. The GO member must pass completely through the insulation crimp die closure.

- (i) Try to insert the NO-GO member. The NO-GO member may enter partially, but must not pass completely through the die closure.
- On tool No. 59489 Mod. L, loosen socket head screw, reposition locator and re-tighten screw.
- (k) If both wire barrel and insulation crimp die closures meet the GO NO-GO gage conditions, the die closures may be considered dimensionally correct.

- (l) If you find that the die closures do not conform with the GO NO-GO gage conditions, contact your local AMP field representative.

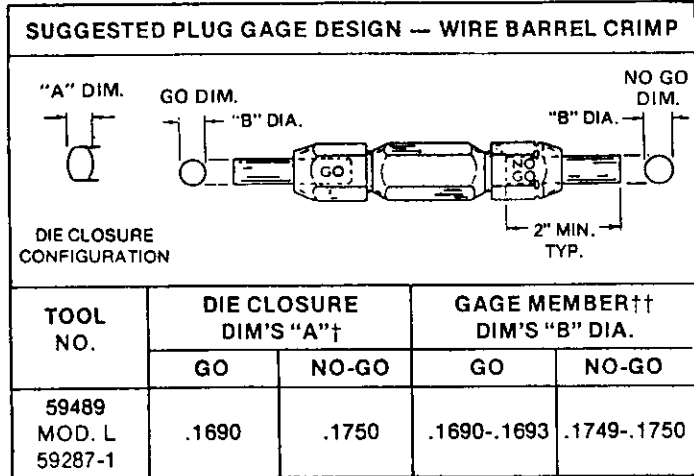
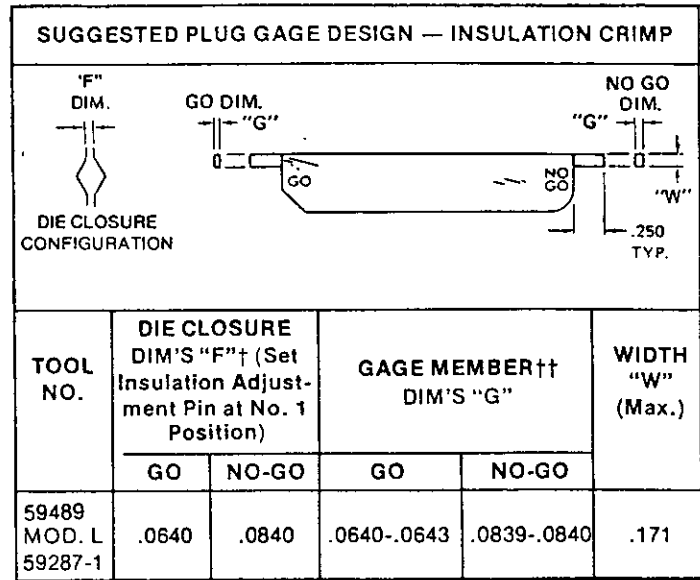

Figure 6



†Die closure dimensions apply when wire barrel dies are bottomed, but not under pressure.
 ††Material — Tool Steel.

Figure 7

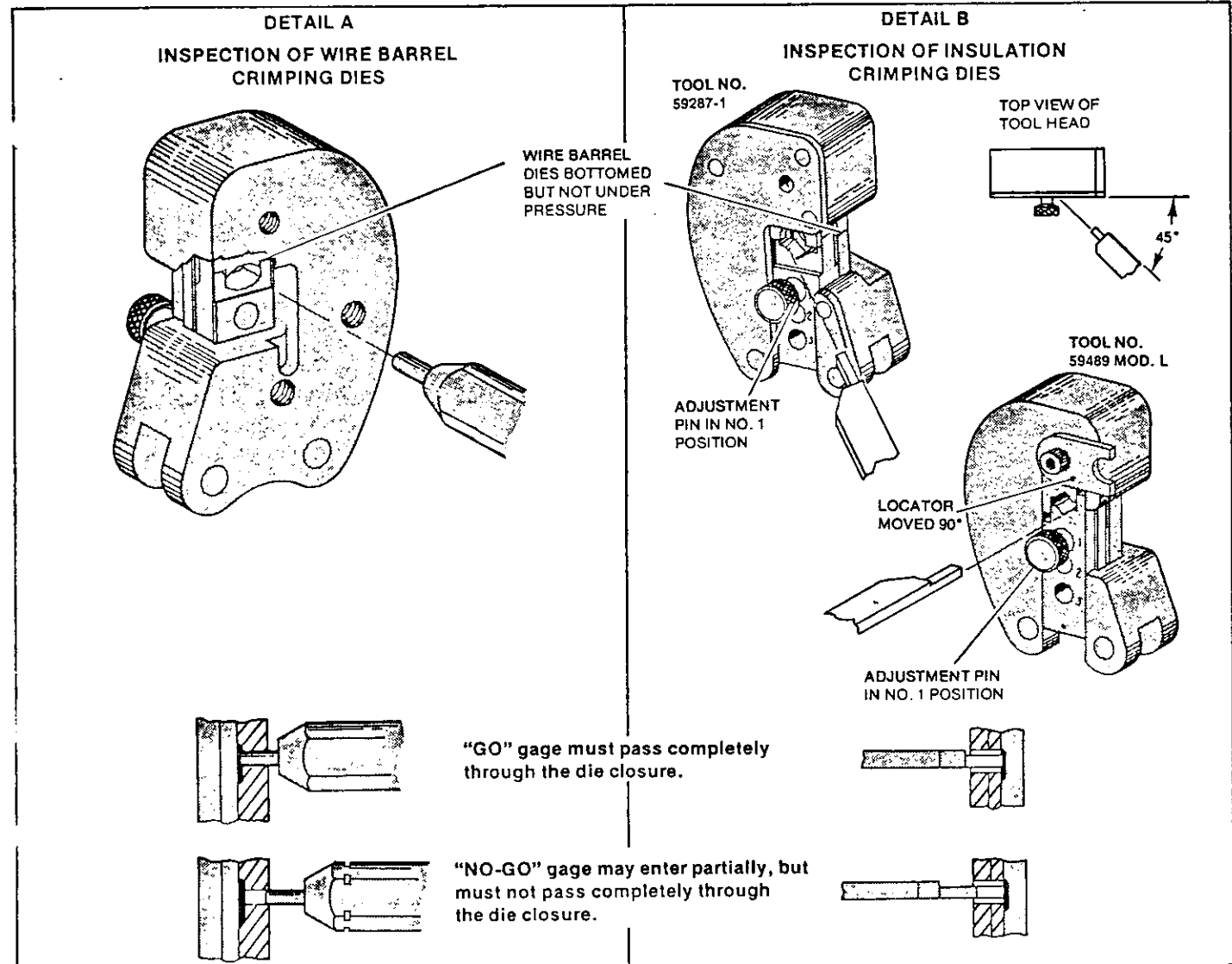

Figure 8

4.5 CERTI-CRIMP RATCHET INSPECTION

The CERTI-CRIMP ratchet feature on hand tools should be checked to make certain that the ratchet does not release prematurely allowing dies to open before they have fully bottomed.

- (a) Thoroughly clean the bottoming surfaces of the dies.
- (b) Make a test crimp using the maximum wire load, i.e., a No. 10 AWG wire in a 12-10 splice. When this crimp is made, squeeze handles until the ratchet is free, however, **DO NOT RELAX PRESSURE ON TOOL HANDLES.**
- (c) Bottoming is satisfactory if bottoming surfaces of the wire barrel crimp dies make contact with each other or if the clearance between the bottoming surfaces is .001" or less.
- (d) If the .001" shim stock can be inserted completely between the bottoming surfaces of the wire barrel

crimp dies, the dies are considered as not bottoming. Contact your local AMP field representative.

4.6 REPLACEMENT PARTS

It may be advantageous to stock certain replaceable parts to prevent loss of production time. Figure 9 lists the customer replaceable parts that can be purchased from AMP Incorporated. Parts other than those listed on Figure 9 should be replaced by AMP Incorporated to insure proper CERTI-CRIMP ratchet adjustments.

For major tool repair service or adjustment, contact your local AMP field representative or return the tool to AMP Incorporated, Tool Repair Service, 1523 N. Fourth Street, Harrisburg, Pennsylvania 17105, or a wholly owned subsidiary of AMP Incorporated.

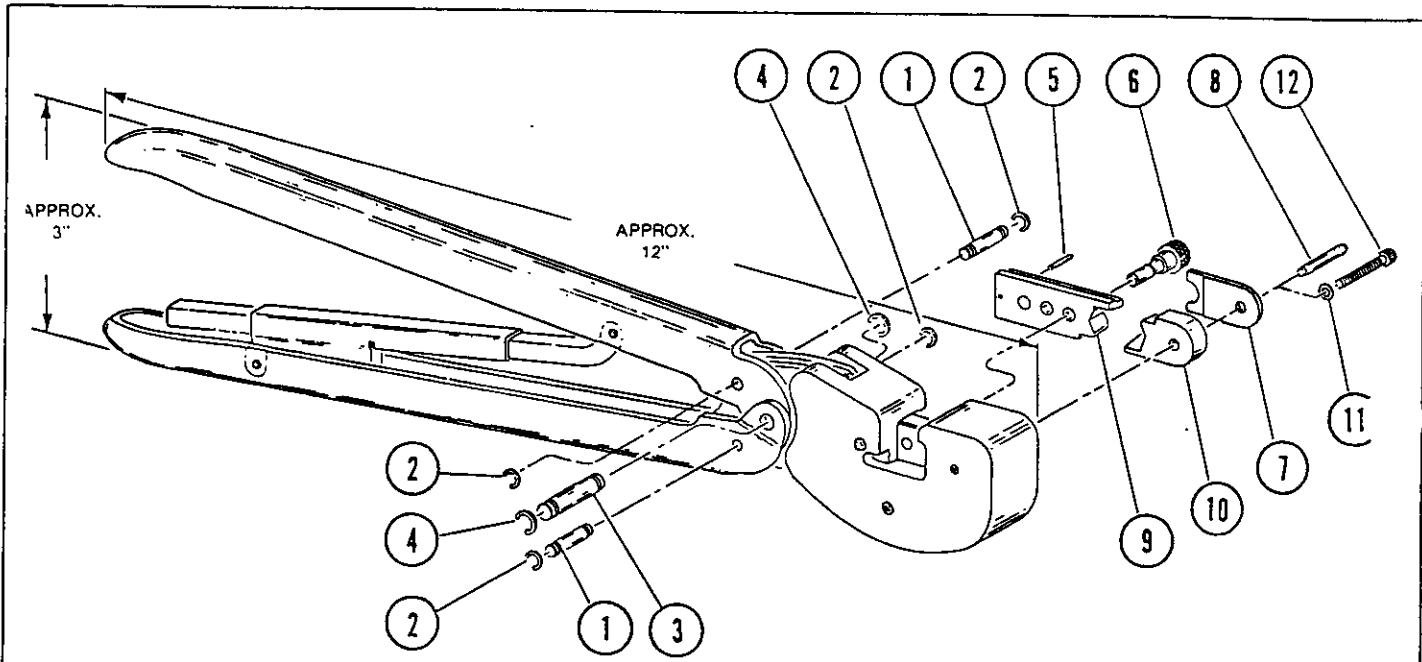

ITEM	DESCRIPTION	QUANTITY	TOOL NUMBERS	
			59287-1	59489 MOD. L
1	PIN, RETAINING	2	300388	300388
2	RING, RETAINING	4	21045-3	21045-3
3	PIN, RETAINING	1	300389	300389
4	RING, RETAINING	2	21045-6	21045-6
5	PIN	1	21028-5	21041-4
6	PIN, ADJUSTMENT	1	303848-2	303848-2
7	LOCATOR	1	5-304052-5	305312
8	PIN	1	5-21028-7	---
9	INSULATION DIE (MOVING)	1	1-306107-0	301147
10	INSULATION DIE (STATIONARY)	1	1-306106-0	301146
11	WASHER, LOCK	1	---	21057-3
12	SCREW	1	---	2-21000-3

Figure 9

REL. DATE	REV. DATE	APPROVALS	
7-28-60	1-8-79	ENG. <i>Hoyd H. Renshaw</i>	PUB. <i>Paul Felty</i>