

Note: When OPEN, TPA Protrudes from Housing by 4.5 mm [.177 in.] (Approx)

TERMINAL			CONNECTOR	
PART NUMBER	DESCRIPTION	QUANTITY	TYPE	POSITION
33012-3002 ●	1.5-mm Tin-Plated Female	18	Plug	1-9, 12-20
33001-3004 ●	1.5-mm Gold-Plated Female			
33000-1002 ●	1.5-mm Tin-Plated Male	18	Cap	
33011-0004 ●	1.5-mm Gold-Plated Male			
7116-4111-02 ■	2.8-mm Tin-Plated Female	2	Plug	10 and 11
7114-4111-02 ■	2.8-mm Tin-Plated Male	2	Cap	

● MOLEX product † ■ YAZAKI product †

Figure 1

1. INTRODUCTION

This instruction sheet covers assembly (inserting terminals into the connectors, installing a body clip, and mating the connectors) and disassembly (unmating the connectors, removing the body clip, and extracting terminals from the connectors) procedures for 20-Way Automotive Unsealed Hybrid Plug Connector Assemblies 2098377-[] and Cap Connector Assemblies 2098380-[]. Recommendations for continuity testing are also covered.

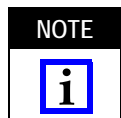

Dimensions in this instruction sheet are in metric units [with U.S. customary units in brackets]. Figures are not drawn to scale.

The connectors accept the terminals listed in Figure 1. A body clip is used to mount the cap connector onto a panel. The following body clips are available separately to assemble onto the cap connector.

† Not available from TE Connectivity.

MOLEX and YAZAKI are trademarks of their respective owners.

CONNECTOR PART NUMBER SUFFIX	BODY CLIP †	
	PART NUMBER	MANUFACTURER
-1, -2, -3	151-00180	Hellermann Tyton
-7, -8, -9	8C3T-13A506-AA	Ford Motor Company
	6S6T-14A592-AA	

2. DESCRIPTION

Each connector features a housing (with terminal cavities) and a TPA. The TPA of the cap connector is protected by a shroud. After all terminals are inserted, the TPA is used to ensure that the terminals are fully seated and provide additional terminal retention.

The connector is shipped with the TPA in the pre-lock OPEN position (1ST STAGE). The TPA is actuated when moved to the CLOSED position (2ND STAGE).

Each row of terminal cavities is marked on the wire end of the connector for circuit identification. The terminal cavities are polarized to prevent the terminals

from being inserted upside-down. When inserted, the terminal deflects a retention finger, locking the terminal into place.

The housing features a key and alignment channels (plug connector) or keying slot and alignment ribs (cap connector). The cap connector features a hold-down retainer, which holds the optional body clip. When mating the connectors, the alignment slots and alignment ribs properly align the connectors. See Figure 1.

3. ASSEMBLY

3.1. Insert Terminals

The following procedure assumes that the terminals have been properly crimped. Refer to Figure 2, Detail A for inserting 1.5-mm terminals and Detail B for inserting 2.8-mm terminals into the plug and cap connectors. Proceed as follows:

1. Ensure that the TPA of the connector is in the OPEN position as shown in Figure 1. If it is not, insert the tip of a small screwdriver into one of the removal slots of the housing (shown in Figure 8), and pry the TPA until it is in the OPEN position. The TPA should protrude from the housing by approximately 4.5 mm [.177 in.]. DO NOT remove the TPA completely from the housing. For the cap connector, note that even though the TPA protrudes from the housing, it is recessed in the shroud.
2. Grasp the wire of the terminal approximately 20 mm [.75 in.] behind the insulation barrel of the terminal, then at the wire end of the connector, align

the terminal with the desired terminal cavity, orienting the terminal so that the alignment tab located on the top of the terminal box (for 1.5-mm terminals) or the orientation tabs located on the sides of the terminal box (for 2.8-mm terminals) is facing the top of the terminal cavity. The orientation of the terminal for the top row is the opposite of the bottom row.

3. Push the terminal straight into the terminal cavity until it stops (there will be an audible “click”).



CAUTION DO NOT force the terminal into the terminal cavity. If there is resistance or the wire “buckles,” pull the terminal out, ensure proper orientation, and re-insert the terminal.

4. After all terminals are inserted, push the TPA into the housing until it stops. The TPA should be flush with the housing (CLOSED position). See Figure 3.



CAUTION Make sure to AVOID pushing the tips of the terminals.

3.2. Test for Continuity

It is recommended using a continuity test fixture that will not cause damage to the terminals. Consult the continuity test fixture manufacturer for acceptable force for probing.

From the mating face of the plug connector, insert the test probe into the access window of the terminal to be tested. See Figure 4.

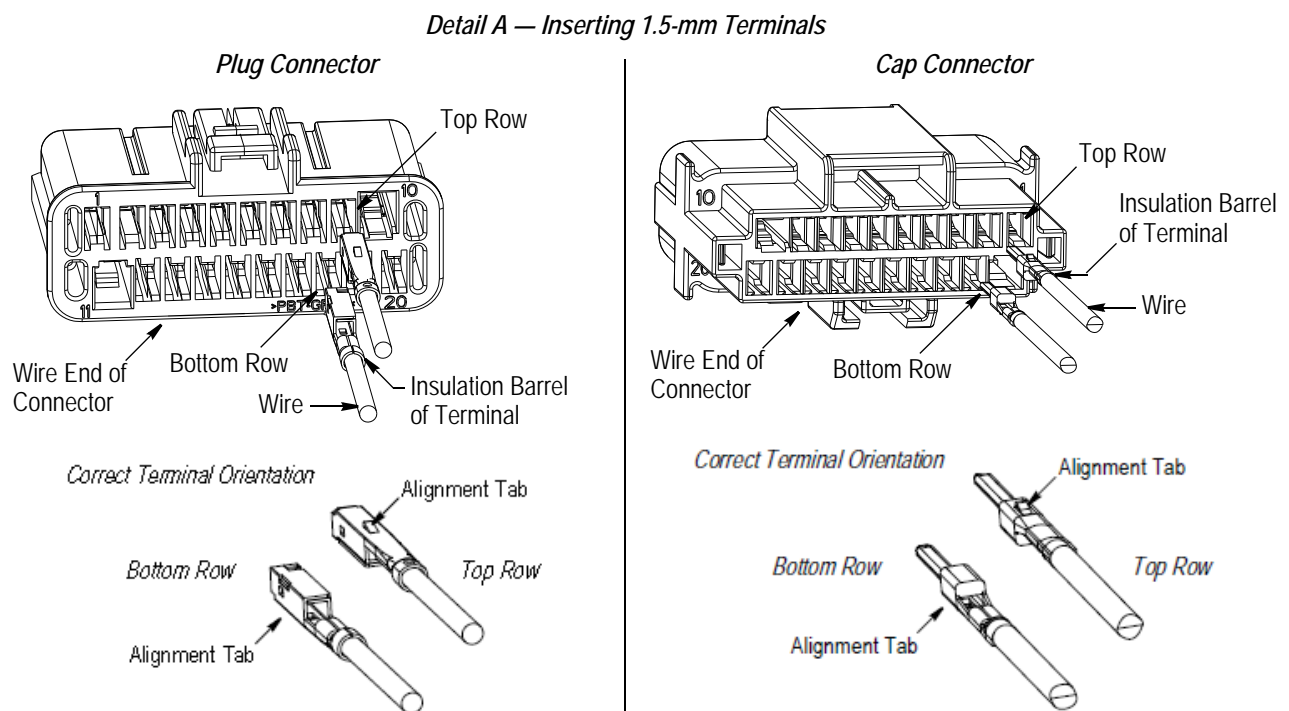

Figure 2 (Cont'd)

Detail B — Inserting 2.8-mm Terminals

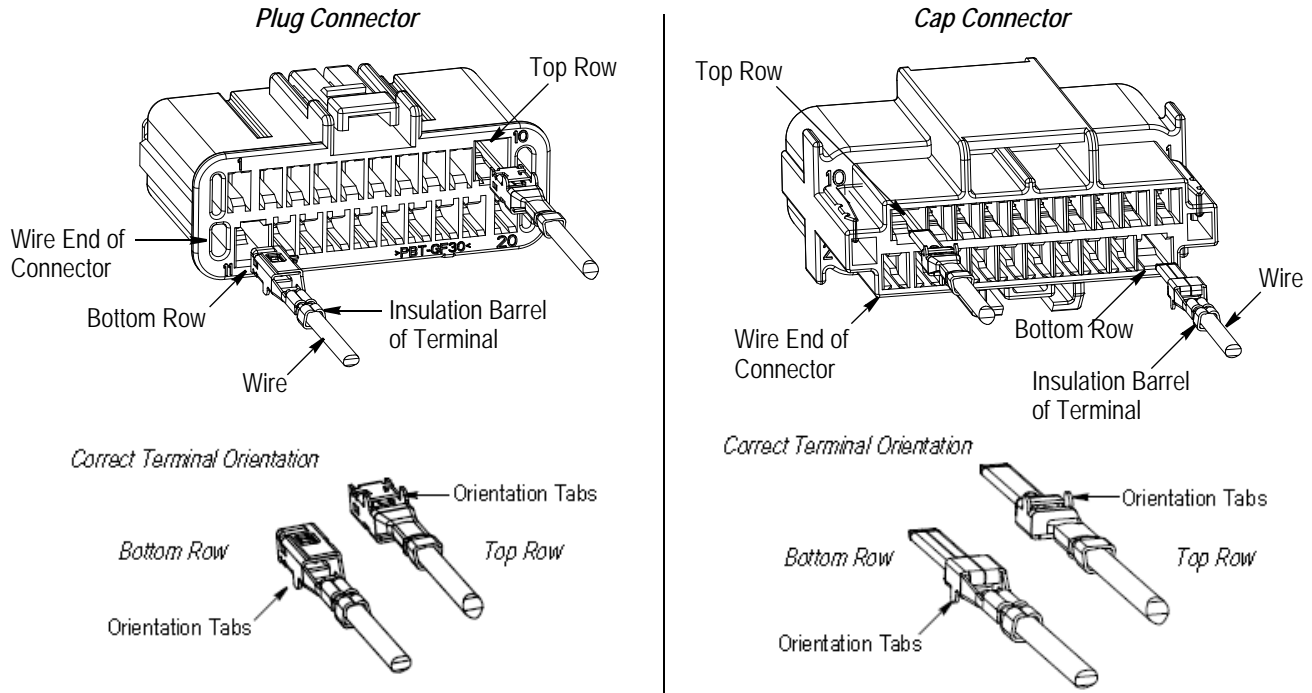

Figure 2 (End)

Moving TPA to CLOSED Position

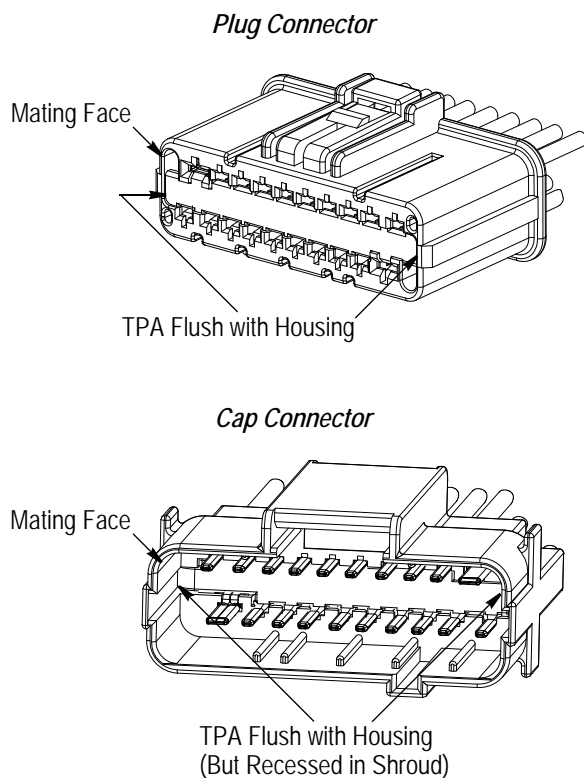

Figure 3



To avoid damage to the terminal, **MAKE SURE** that the probe does not apply excessive force to the tip of the terminal.

Continuity Testing

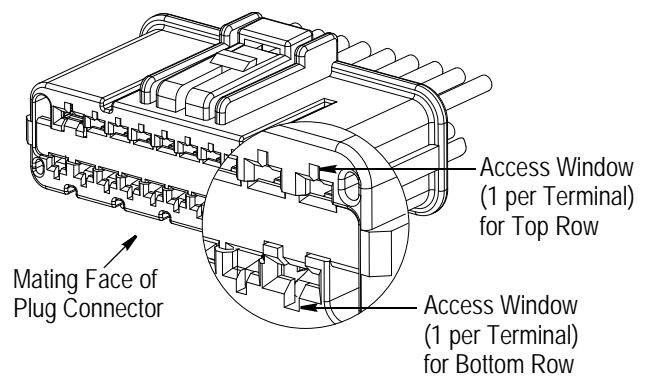

Figure 4

3.3. Install Body Clip (Optional)

1. Align the body clip with the mating face of the cap connector so that the latch faces the end of the hold-down retainer of the cap connector. See Figure Figure 5, Detail A.
2. Slide the body clip onto the hold-down retainer until it is fully seated (there will be an audible or haptic “click”). See Figure Figure 5, Detail B.

Installing Body Clip (Optional)

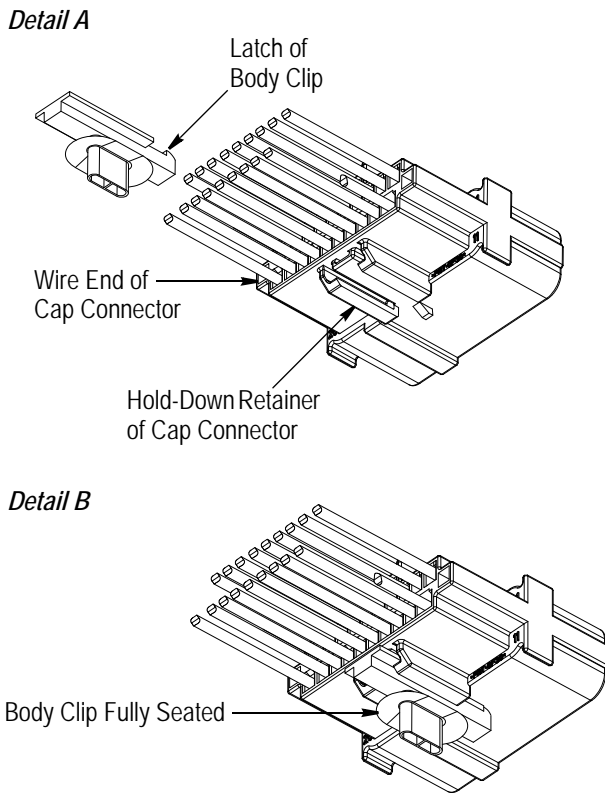

Figure 5

Mating Connectors

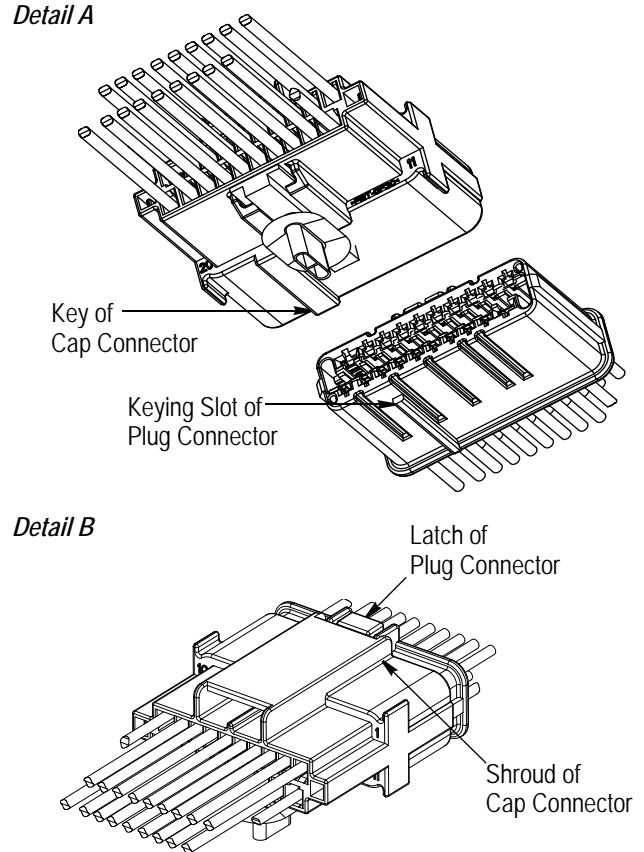

Figure 6

3.4. Mate Connectors

1. Align the mating faces of the connectors so that the key of the cap connector faces the keying slot of the plug connector. See Figure Figure 6, Detail A.
2. Push the connectors together so that the alignment ribs enter the alignment slots and until the latch of the plug connector engages the shroud of the cap connector (there will be an audible “click”). See Figure 6, Detail B.

4. DISASSEMBLY

4.1. Unmating Connectors

Depress the latch of the plug connector (shown in Figure 6), and simultaneously pull the connectors apart.

4.2. Removing Body Clip

1. From the mating face of the cap connector, slide the tip of a flat blade screwdriver into the hold-down retainer so that it is under the latch of the body clip. See Figure 7.
2. Rotate the screwdriver so that the latch of the body clip is free from the hold-down retainer.
3. Slide the body clip out of the hold-down retainer.

Removing Body Clip

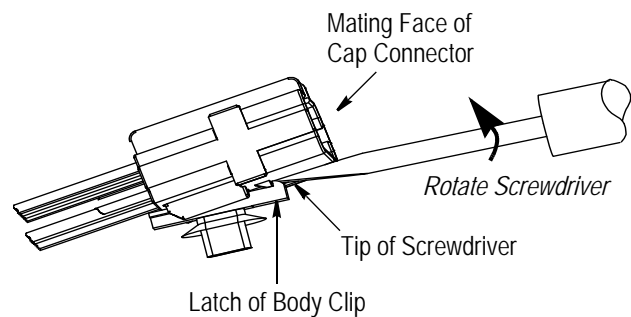

Figure 7

4.3. Extracting Terminals

1. Remove the TPA from the housing of the connector as follows:

For the plug connector, from the mating face, insert the tip of a small screwdriver into one of the removal slots, and pry the TPA out and away from the housing. Refer to Figure 8, Detail A.

For the cap connector, from the wire end, insert the tip of a small screwdriver into one of the

removal slots, rotate the screwdriver to pry the TPA latch toward the wires, then push the TPA out of the mating face of the connector and away from the housing. Refer to Figure 8, Detail B.

Removing TPA (for Extracting Terminals)

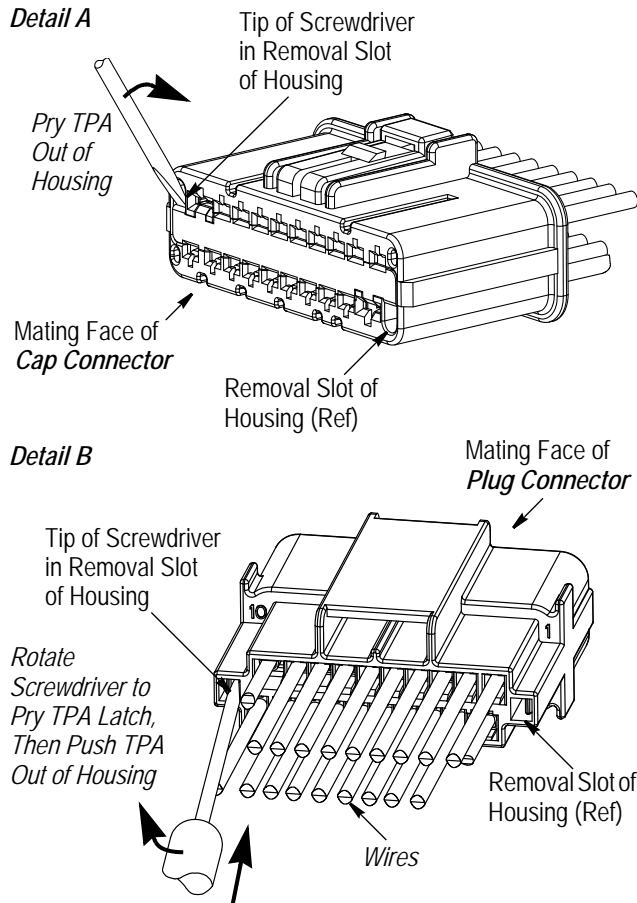
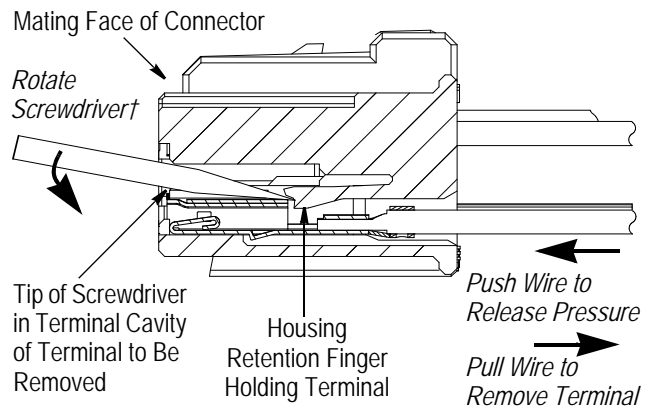

Figure 8

2. At the mating face of the connector, insert the tip of a flat blade screwdriver into the terminal cavity of the terminal to be removed until it stops. See Figure 9, Detail A (plug connector) and Detail B (cap connector).
3. Holding the screwdriver in place, gently push the wire of the terminal to be removed toward the housing until it stops (this will release the pressure on the terminal).
4. Rotate the screwdriver toward the terminal to lift the housing retention finger away from the terminal. While holding the screwdriver in position, pull the wire until the terminal is released, then pull the terminal straight out of the terminal cavity.
5. Pull the screwdriver out of the connector.
6. Insert a new terminal according to Paragraph 3.1, and test the terminal following the recommendations given in Paragraph 3.2.

Extracting Terminals

Detail A — Plug Connector — Bottom Row Shown



† Rotate Screwdriver Opposite Direction for Top Row

Detail B — Cap Connector — Top Row Shown

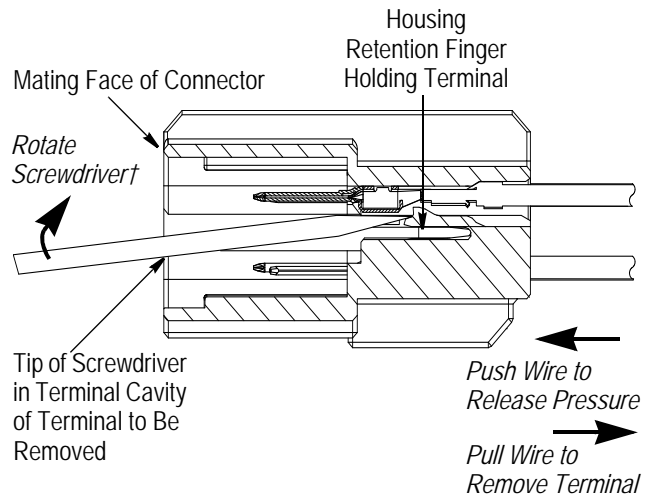

† Rotate Screwdriver Opposite Direction for Bottom Row

Figure 9

7. Re-install the TPA into the housing of the connector and move it to the CLOSED position as follows:
 - a. From the mating face of the connector, align the terminal cavities of the TPA with the tips of the terminals.
 - b. Carefully, slide the TPA into the connector until it stops. Be careful not to bend any of the terminals. If a terminal is bent, replace it.

5. REPLACEMENT AND REPAIR

The connectors and terminals are not repairable. DO NOT use any defective or damaged connectors or terminals. DO NOT re-use a terminated terminal by removing the wire.

6. REVISION SUMMARY

- Changed position information in table in Figure 1