

| REVISIONS | | | |
|-----------|------------------------|-------------|----|
| REV | DATE | DESCRIPTION | BY |
| C | REV PER ECH 8000202708 | | GG |

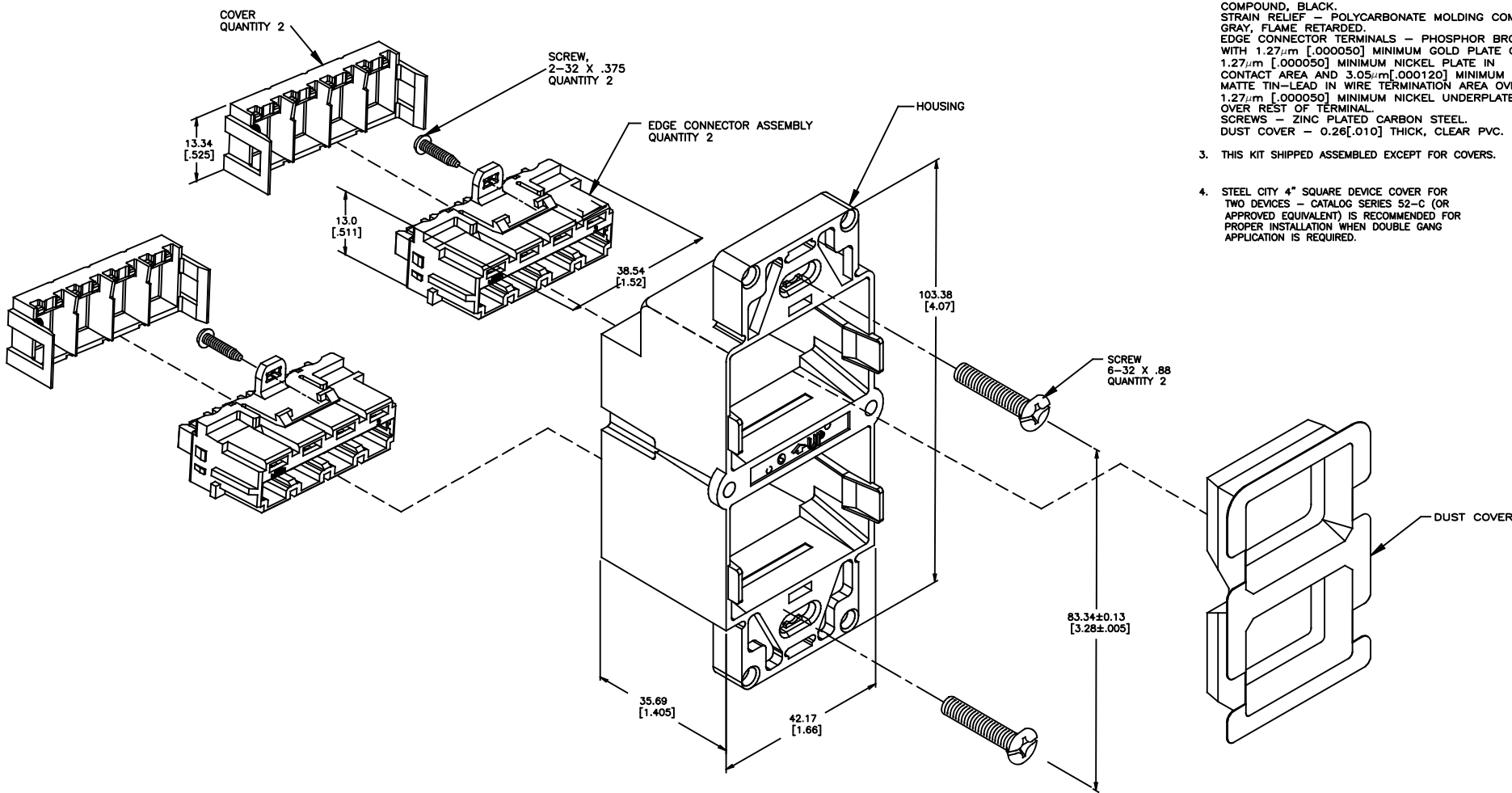

EXPLODED VIEW

1. DIMENSIONS ARE MAXIMUM UNLESS OTHERWISE SHOWN.
2. MATERIAL:
 HOUSING — ABS MOLDING COMPOUND, NATURAL.
 EDGE CONNECTOR HOUSING — POLYESTER MOLDING COMPOUND, BLACK.
 STRAIN RELIEF — POLYCARBONATE MOLDING COMPOUND, GRAY, FLAME RETARDED.
 EDGE CONNECTOR TERMINALS — PHOSPHOR BRONZE WITH 1.27µm [.000050] MINIMUM GOLD PLATE OVER 1.27µm [.000050] MINIMUM NICKEL PLATE IN CONTACT AREA AND 3.05µm [.000120] MINIMUM MATTE TIN-LEAD IN WIRE TERMINATION AREA OVER 1.27µm [.000050] MINIMUM NICKEL UNDERPLATE OVER REST OF TERMINAL.
 SCREWS — ZINC PLATED CARBON STEEL.
 DUST COVER — 0.26[.010] THICK, CLEAR PVC.
3. THIS KIT SHIPPED ASSEMBLED EXCEPT FOR COVERS.
4. STEEL CITY 4" SQUARE DEVICE COVER FOR TWO DEVICES — CATALOG SERIES 52-C (OR APPROVED EQUIVALENT) IS RECOMMENDED FOR PROPER INSTALLATION WHEN DOUBLE GANG APPLICATION IS REQUIRED.

406091-1
 PART NO.

| | | | | | |
|--|--|-----------------|------------|---|----------|
| THIS DRAWING IS A CONTROLLED DOCUMENT. | | REV | T | SPRINKLE | SECTION |
| DIMENSIONS: mm [inches] | | DATE | 11-17-2016 | STATUS | Standard |
| MATERIAL | | APP | 11-17-2016 | STATUS | Standard |
| GENERAL | | PROJ | 11-17-2016 | STATUS | Standard |
| CUSTOMER DRAWING | | SCALE | 2:1 | SHEET | 1 of 1 |
| CUSTOMER DRAWING | | DATE CODE | 8000202708 | REV | C |
| CUSTOMER DRAWING | | COMMSCOPE, INC. | | INSTALLATION KIT, SMALL, UNSHIELDED AMP COMMUNICATION OUTLET II | |