

THIS DRAWING IS UNPUBLISHED. RELEASED FOR PUBLICATION ,19 .
 © COPYRIGHT 19 BY AMP INCORPORATED. ALL RIGHTS RESERVED.

LOC		DIST		REVISIONS			
P	LTR	DESCRIPTION	DATE	DWN	APVD		
G	14	K	08S / 0L20-0106-96	03DEC96	MLE	TM	

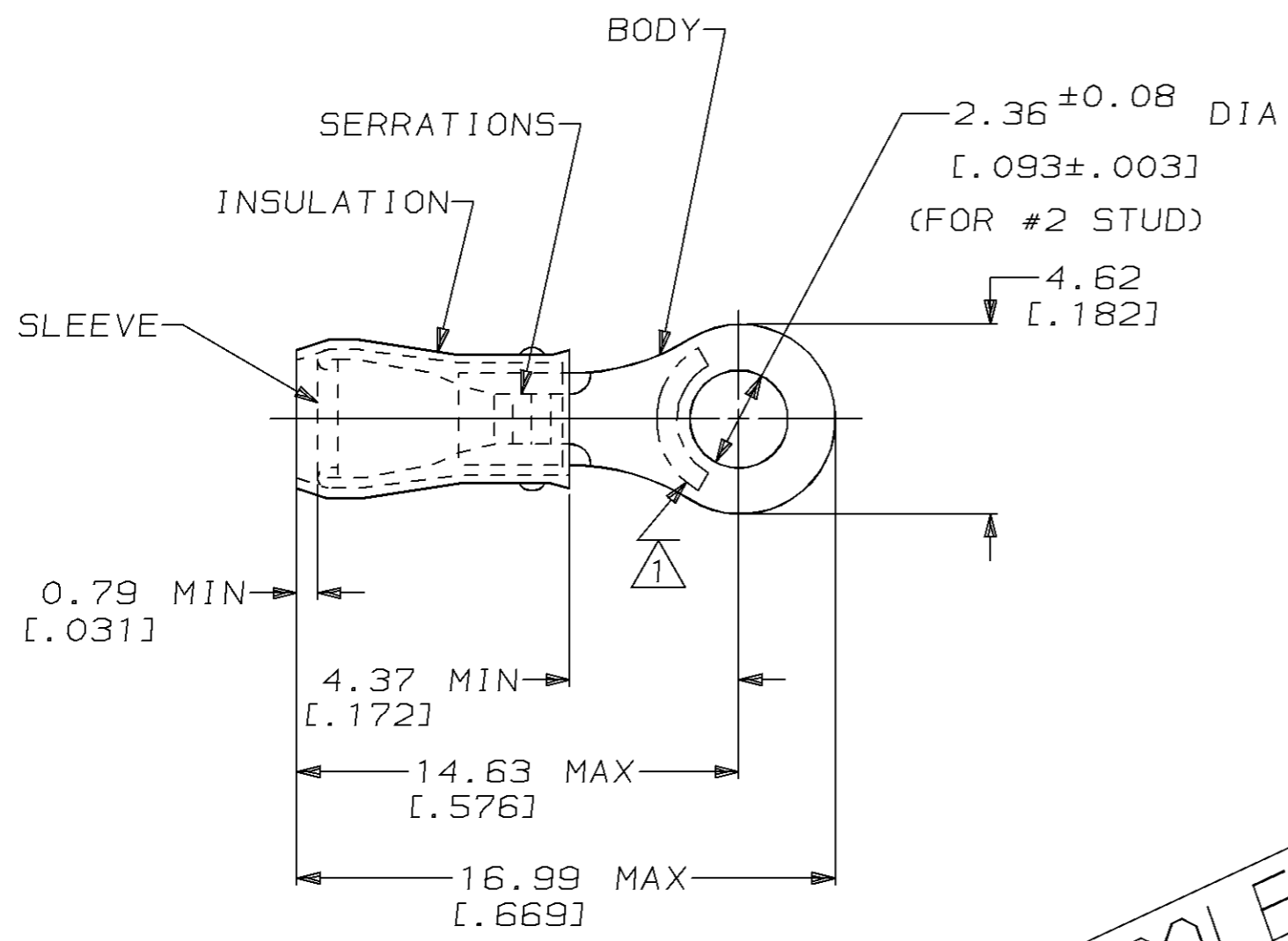

- 1 STAMP AMP 22-18* APPROX AS SHOWN
22-16 TERMINALS ARE STAMPED 22-18 IN
ACCORDANCE WITH MILITARY SPEC MIL-T-7928
COMMERCIAL WIRE RANGE IS 22-16
- 2. WIRE INSUL DIA, 2.03-3.17 [.080-.125]
- 3. TONGUE MATERIAL THK, 0.79^{±0.05} [.031^{±.002}]
- 4. FOREIGN PRODUCTION ONLY
- 5 REPLACED BY 324158

OBSOLETE

-	-	-
-	-	-
5	LOOSE PIECE	320440
QTY	PACKAGE TYPE	PART NO

AMP INCORPORATED CUSTOMER SERVICE SYSTEM		MAX RECOMMENDED OPERATING TEMPERATURE: 105°C [221°F]	THIS DRAWING IS A CONTROLLED DOCUMENT FOR AMP INCORPORATED. IT IS SUBJECT TO CHANGE AND THE CONTROLLING ENGINEERING ORGANIZATION SHOULD BE CONTACTED FOR THE LATEST REVISION.		DWN M ELLIS 16JUN95	AMP AMP Incorporated Harrisburg, PA 17105-3608			
FOR ADDITIONAL PRODUCT INFORMATION OR COPIES OF DRAWINGS AND TECHNICAL DOCUMENTS	PRODUCT INFORMATION CENTER 1-800-522-6752	VOLTAGE RATING: 300 V MAX	DIMENSIONS: mm [in]	TOLERANCES UNLESS OTHERWISE SPECIFIED:	CHK C PRESNELL 16JUN95	NAME N BIRCH PRODUCT SPEC TERMINAL, RING TONGUE, PIDG™, WIRE SIZE, 22-16 AWG			
FOR APPLICATION TOOLING INFORMATION	TOOLING ASSISTANCE CENTER 1-800-722-1111	CIRCULAR MIL AREA: 0.26mm² - 1.65mm² [509-3260]		0 PLC ±- 1 PLC ±- 2 PLC ±0.20 [.008] 3 PLC ±- 4 PLC ±- ANGLES ±-	APVD 16JUN95			APPLICATION SPEC	
FOR ORDER ENTRY	1-800-526-5142		MATERIAL BODY, SLV, COPPER PER ASTM-B-152 INSUL, PVC, COLOR, RED	FINISH BODY & SLV, TIN PLATE PER MIL-T-10727	WEIGHT -	SIZE A3	CAGE CODE 00779	DRAWING NO G-320440	
					CUSTOMER DRAWING		SCALE 4:1	SHEET 1 OF 1	REV K