

4

3

2

1

CONVERSION CHART	
INCH	MM
.002	0.05
.010	0.25
.016	0.40
.020	0.50
.024	0.60
.035	0.88
.039	0.99
.059	1.49
.079	2.00
.090	2.28
.098	2.48
.115	2.92
.138	3.50
.157	3.98
.167	4.24
.216	5.48
.270	6.85
.276	7.01
.344	8.73
.368	9.34
.400	10.16
.410	10.41
.472	11.98
.512	13.00
.905	22.98
.945	24.03

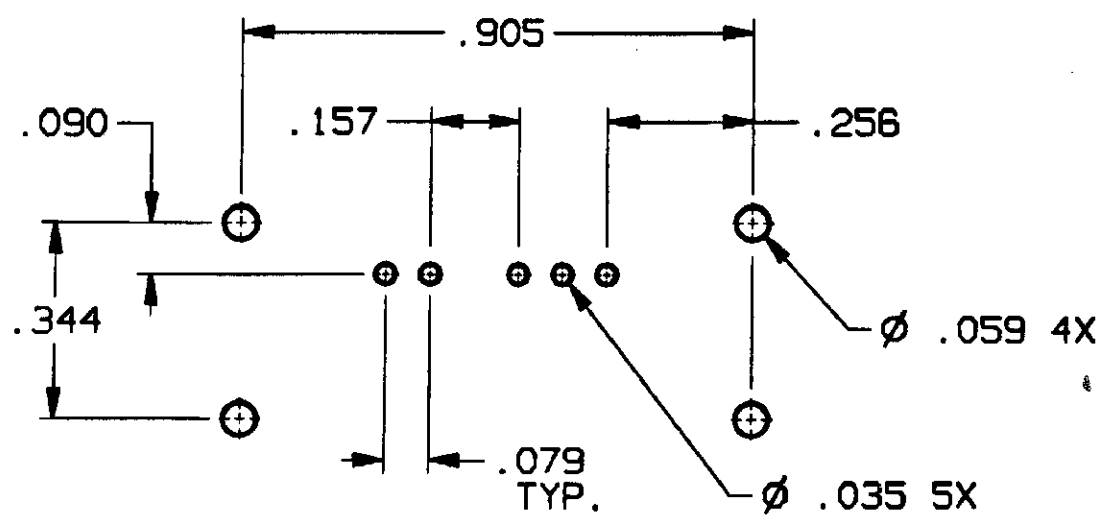
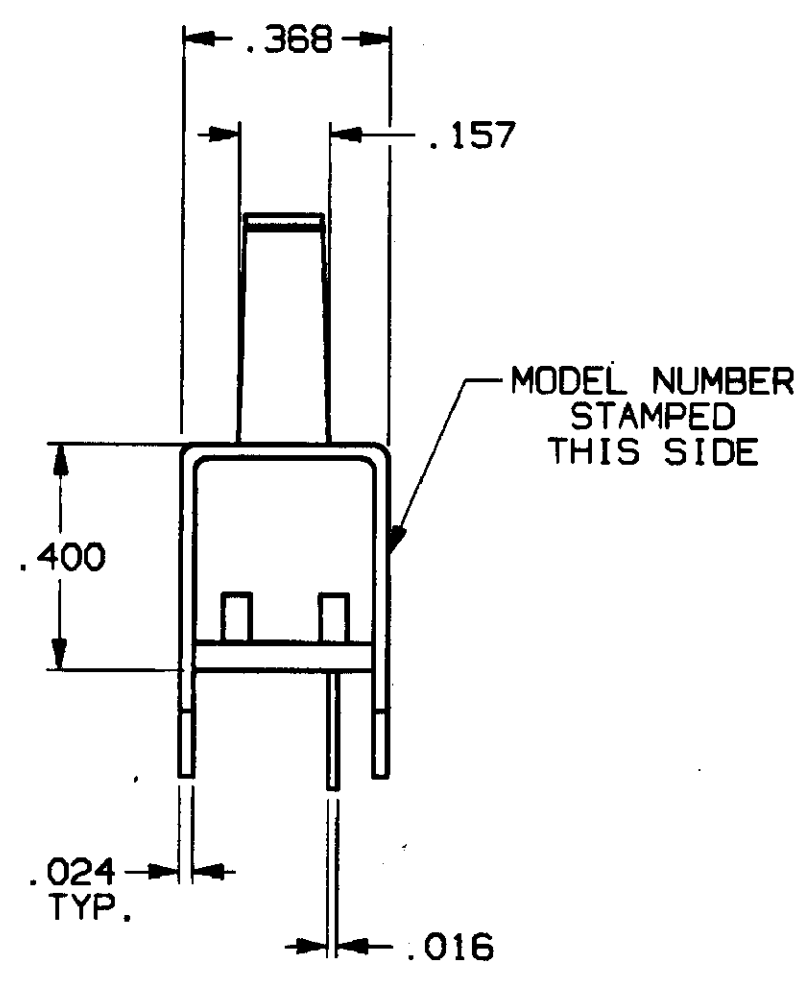
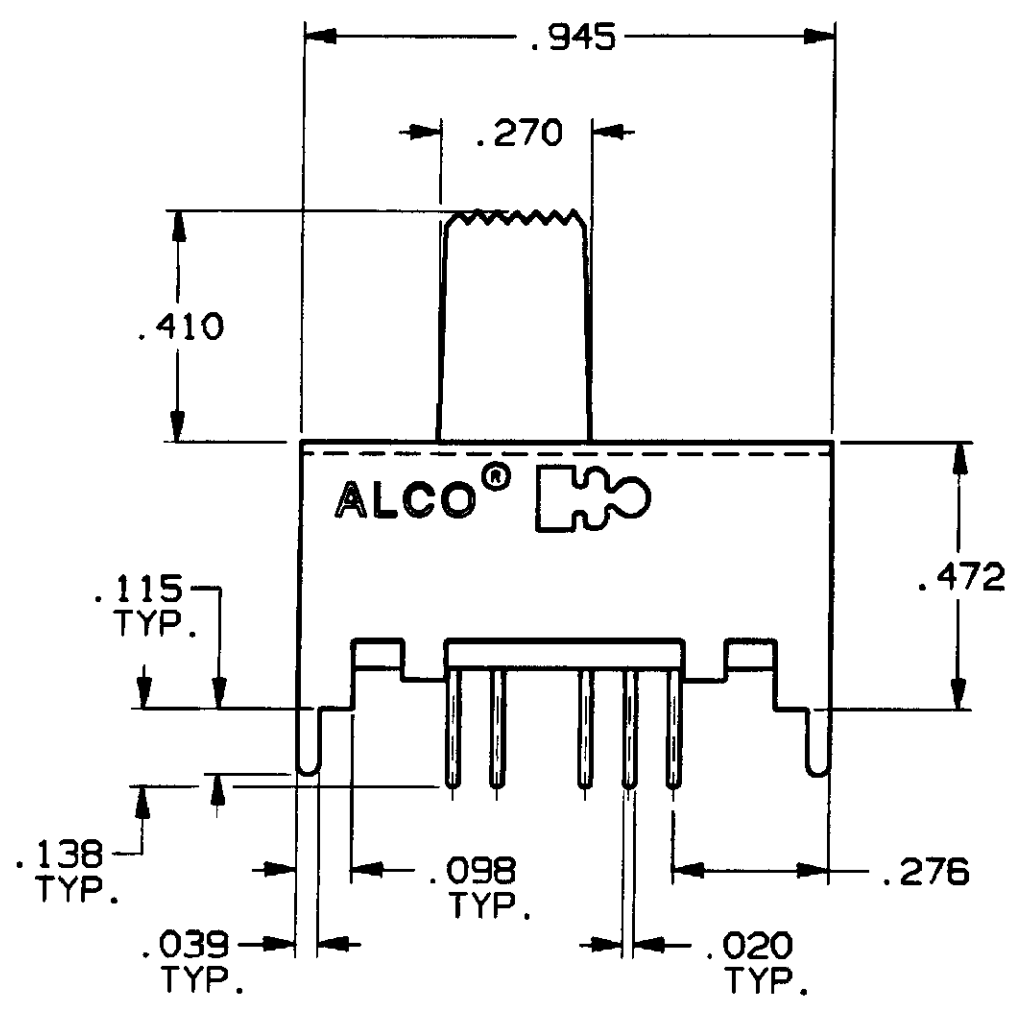
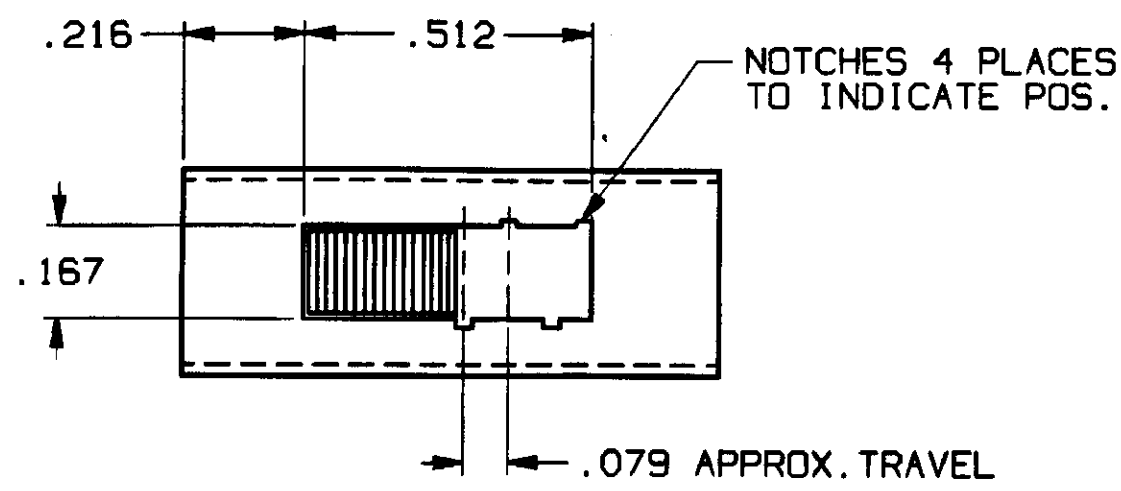

PC BOARD LAYOUT, TOP VIEW
RECOMMENDED TOLERANCES ±.002

SPECIFICATIONS:

MATERIALS:
CASE: COLD ROLLED STEEL.
ACTUATOR: POLYESTER, UL94V-0.
TERMINALS: GOLD OR SILVER PLATE.
TERMINAL SEAL: EPOXY.
CONTACTS, MOVING: COPPER ALLOY, GOLD OR SILVER PLATE.
CONTACTS, FIXED: COPPER ALLOY, GOLD OR SILVER PLATE.

ELECTRICAL:
CONTACT RATING, SILVER: 300 MA @ 125 VAC.
CONTACT RATING, GOLD: 0.4 VA MAX. @ 20 VDC OR PEAK AC.
INITIAL CONTACT RESISTANCE: 30 MILLIOHMS MAX.
INSULATION RESISTANCE: 1,000 MEGOHMS MIN.
DIELECTRIC STRENGTH: 500 VOLTS RMS @ SEA LEVEL.
LIFE EXPECTANCY: 15,000 CYCLES.

MECHANICAL:
ACTUATION FORCE: 600 ±300 GRAMS.
ACTUATOR TRAVEL: .079 IN.

ENVIRONMENTAL:
SOLDER HEAT RESISTANCE:
OPERATING TEMPERATURE: -4°F TO +185°F, (-20°C TO +85°C).
STORAGE TEMPERATURE: -40°F TO +212°F, (-40°C TO +100°C).

NOTES:

1. INTERPRET DRAWING PER ANSI Y14.5M 1982.

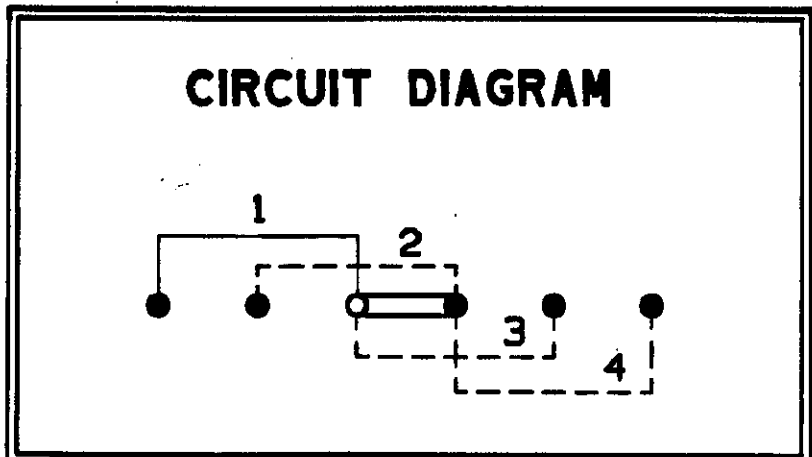

MODEL NO.	PLATING
MSSA-3450	SILVER
MSSA-3450 G	GOLD

AUGAT D/N 40043-SD

THIS IS A C.A.D. GENERATED DRAWING.
DO NOT MAKE MANUAL REVISIONS TO MASTER.

REV	A
REVISIONS	0G3C-0173-02

CUSTOMER DRAWING			
SPECIFICATIONS ARE SUBJECT TO CHANGES WITHOUT NOTICE			
THIRD ANGLE PROJECTION TOLERANCES (EXCEPT AS NOTED) ANGULAR = ±1° DECIMAL .XXX = ±.010 AUGAT CONFIDENTIAL This document contains information which is the exclusive property of Augat Inc. Distribution, reproduction or use by others is not permitted without the expressed written consent of Augat Inc.	UNLESS OTHERWISE SPECIFIED DIMENSIONS ARE IN MILLIMETERS. DO NOT SCALE PRINT MATERIAL: SEE SPECIFICATIONS FINISH: SEE SPECIFICATIONS	ORIGINAL DATE OF DRAWING: 9-17-96 DRAWN: C. THEODORE CHECKED: APPROVED: CODE IDENT. NO. 91506 NEXT ASSY:	DATE: 9-17-96 DATE: DATE: DWG. SIZE C

TYCO ELECTRONICS	
TITLE: CUSTOMER DRAWING SLIDE SWITCH, (SP 4 POS.) MSSA-1450 SERIES	
DWG. NO. 3-1437580-7	REV. A
PRODUCT CODE:	SCALE: SHEET 1 OF 1

4

3

2

1