

REVISIONS				
P	LTR	DESCRIPTION	DATE	APVD
A2		WIRE RANGE IS UPDATED	26OCT2018	SV

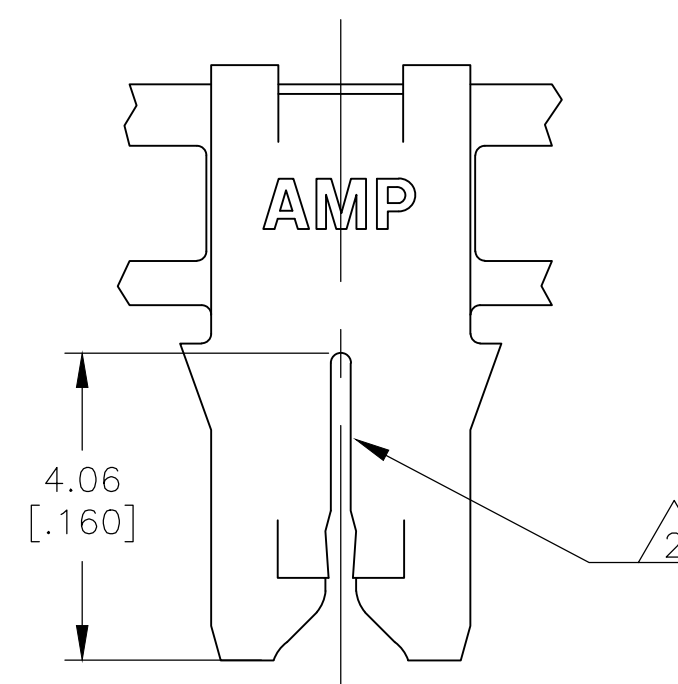
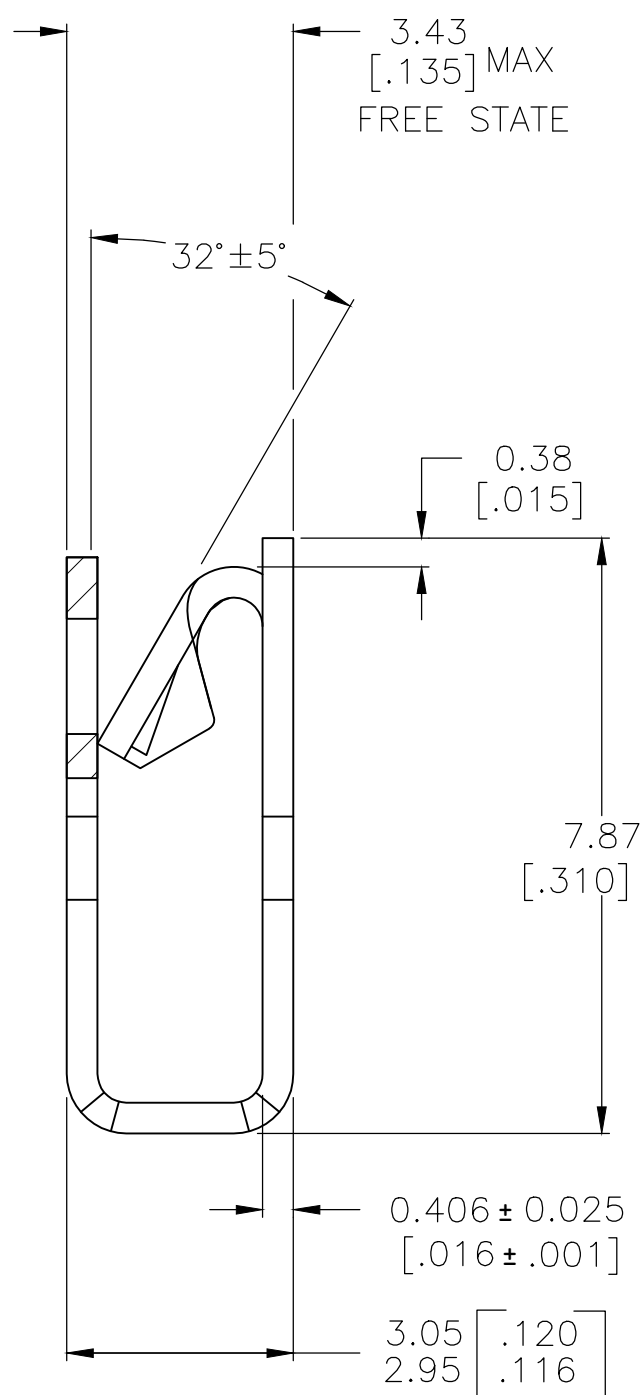
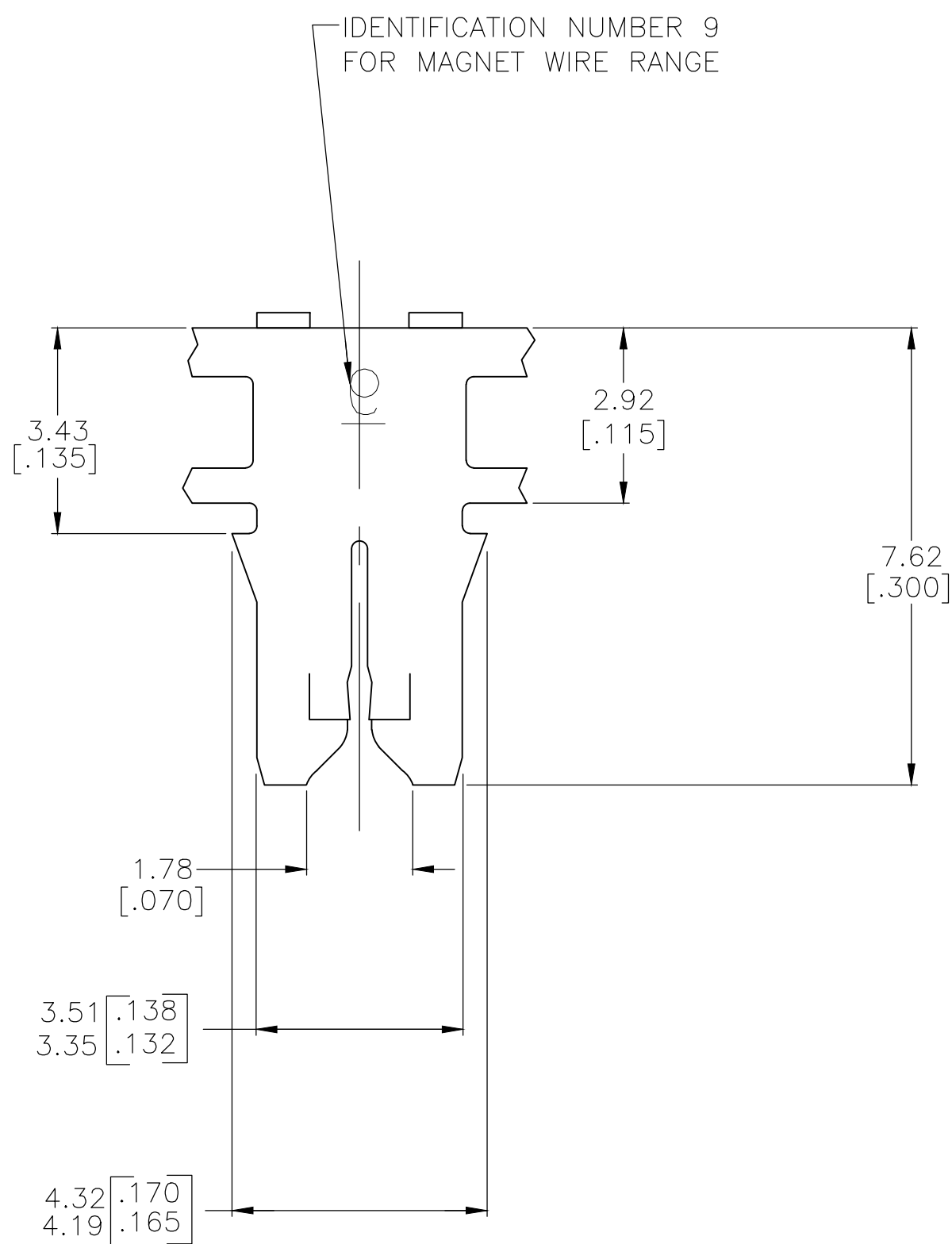
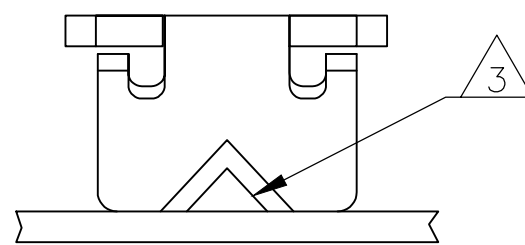

- 1 CONTINUOUS STRIP ON REELS WITH TERMINALS LOCATED ON 5.59±0.08[.220±.003] CENTERS.
- 2 SLOT ACCEPTS A SINGLE OR DOUBLE WIRE ONLY
COPPER WIRE RANGE 0.36–0.51mm [#27–#24] AWG
ALUMINUM WIRE RANGE 0.45–0.51mm [#25–#24] AWG
- 3 POKE-IN ACCEPTS A 0.50–0.90 mm² [#20–#18 AWG] SOLID OR FUSED STRANDED LEAD WIRE.
- 4 PART WILL ACCEPT EITHER POKE-IN TAB OR FUSED LEAD WIRE.

PAPER	CARDBOARD REEL	TIN PLATED	BRASS	2825380-1
SPLICE	REELING MATERIAL	FINISH	MATERIAL	PART NO
THIS DRAWING IS A CONTROLLED DOCUMENT.		DWN BASVESH WARAD 09NOV2016		
DIMENSIONS: mm[INCHES]		CHK SUBRAMANIAN, VIJAI 09NOV2016		
TOLERANCES UNLESS OTHERWISE SPECIFIED:		APVD SUBRAMANIAN, VIJAI 09NOV2016		
0 PLC ± - 1 PLC ± - 2 PLC ± 0.25 [.010] 3 PLC ± - 4 PLC ± - ANGLES ± -		NAME		
MATERIAL SEE TABLE		FINISH SEE TABLE	PRODUCT SPEC 108-2012	APPLICATION SPEC 114-2046
		WEIGHT 0	SIZE A2	CAGE CODE 00779
		CUSTOMER DRAWING	DRAWING NO C=2825380	RESTRICTED TO -
		SCALE 10:1	SHEET 1 OF 1	REV A2