

REVISIONS					
REV	LTN	DESCRIPTION	DATE	OWN	APVD
A1	ECR-18-007348	: 2294162-2 ADDED	1DEC2018	SK	WK
A2	ECR-19-003999	: VIEWS ADDED	14MAR2019	SK	WK
A3	ECR-19-014157	: 2294162-3 ADDED	08JAN2020	PK	WK
A4	ECR-23-164294	: 2294162-4 AND -5 ADDED	20JAN2022	PM	SM
A5	ECR-24-214700	: 2294162-6 ADDED	25JUL2024	PM	SM

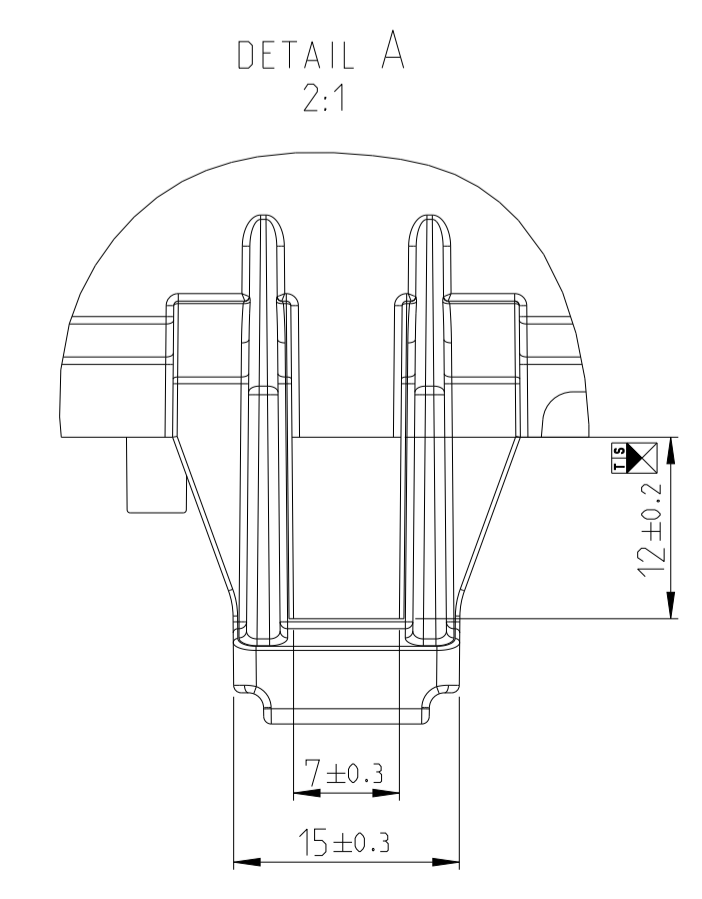
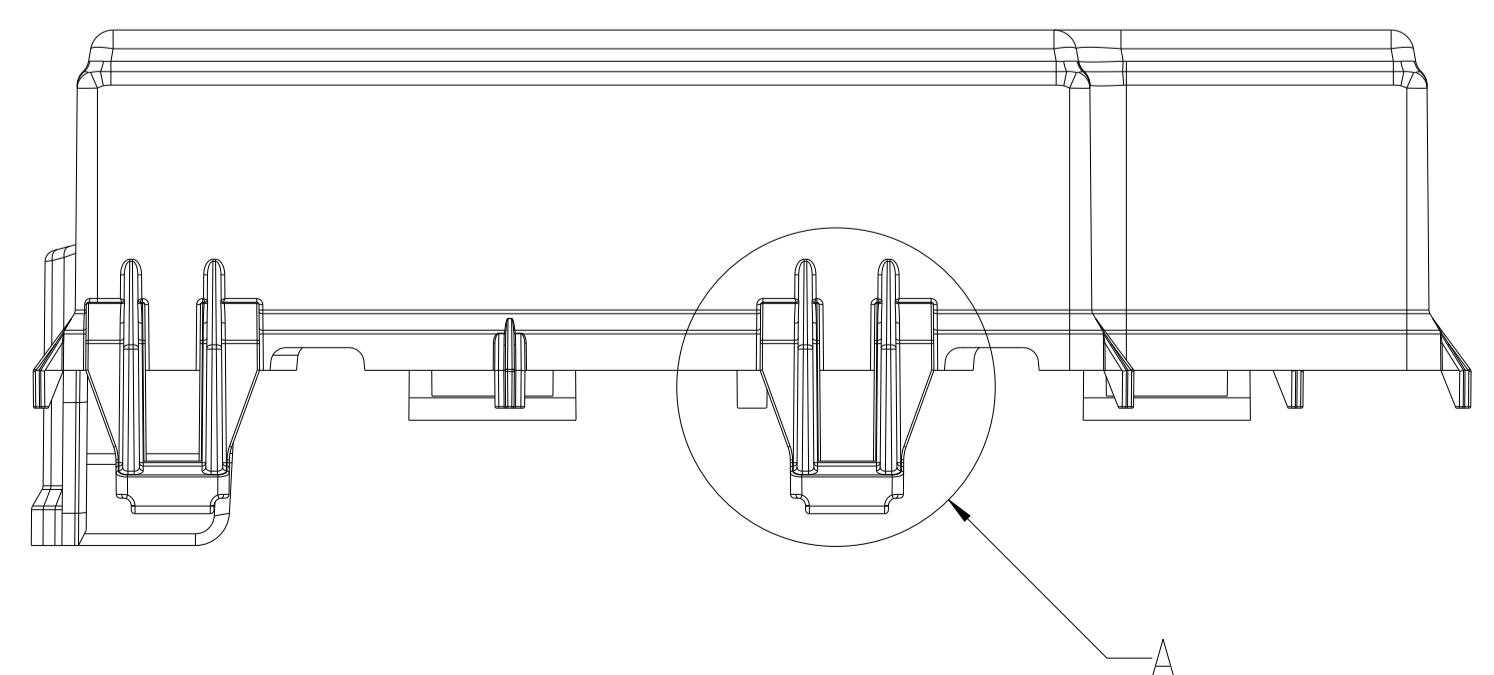
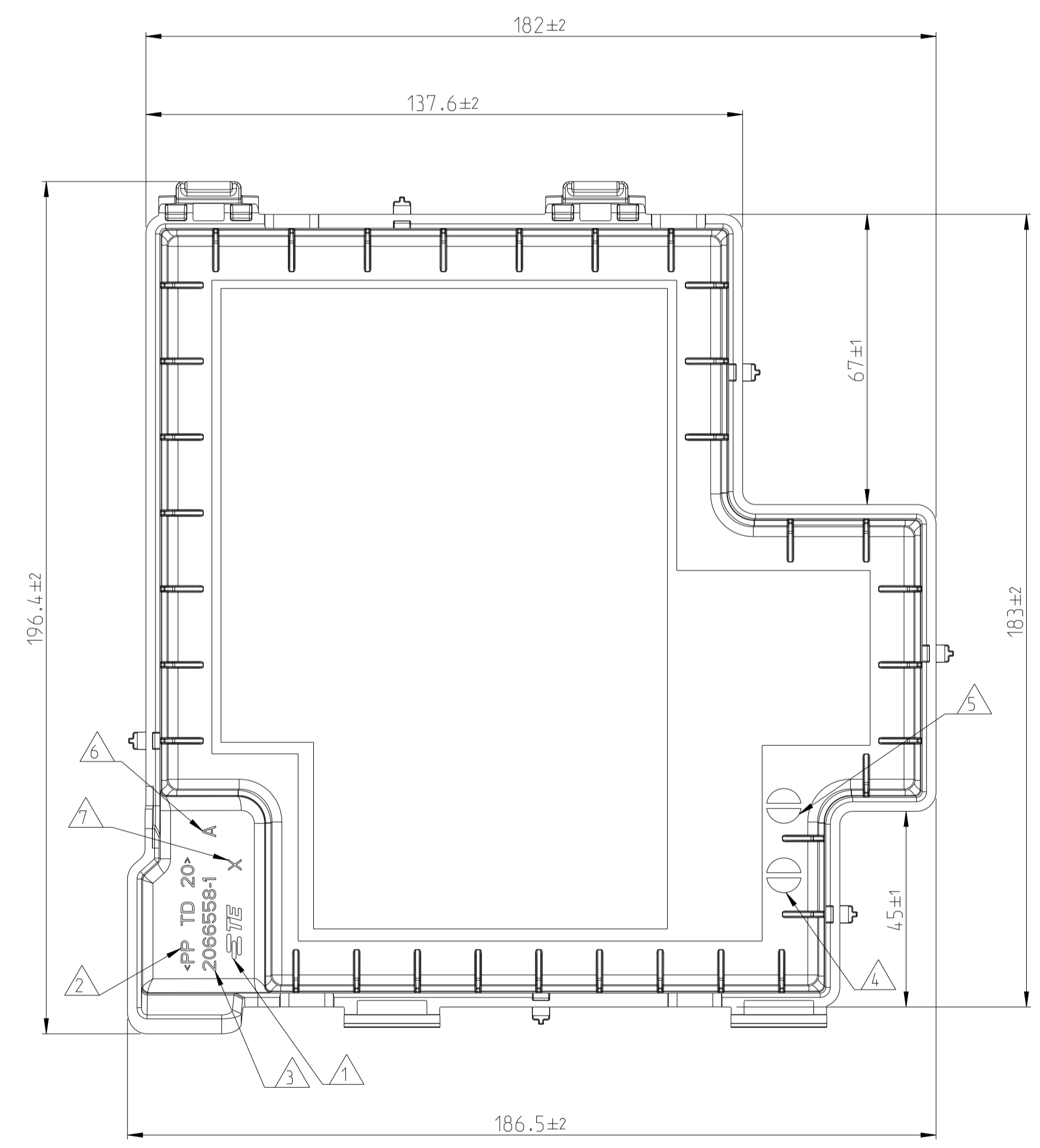
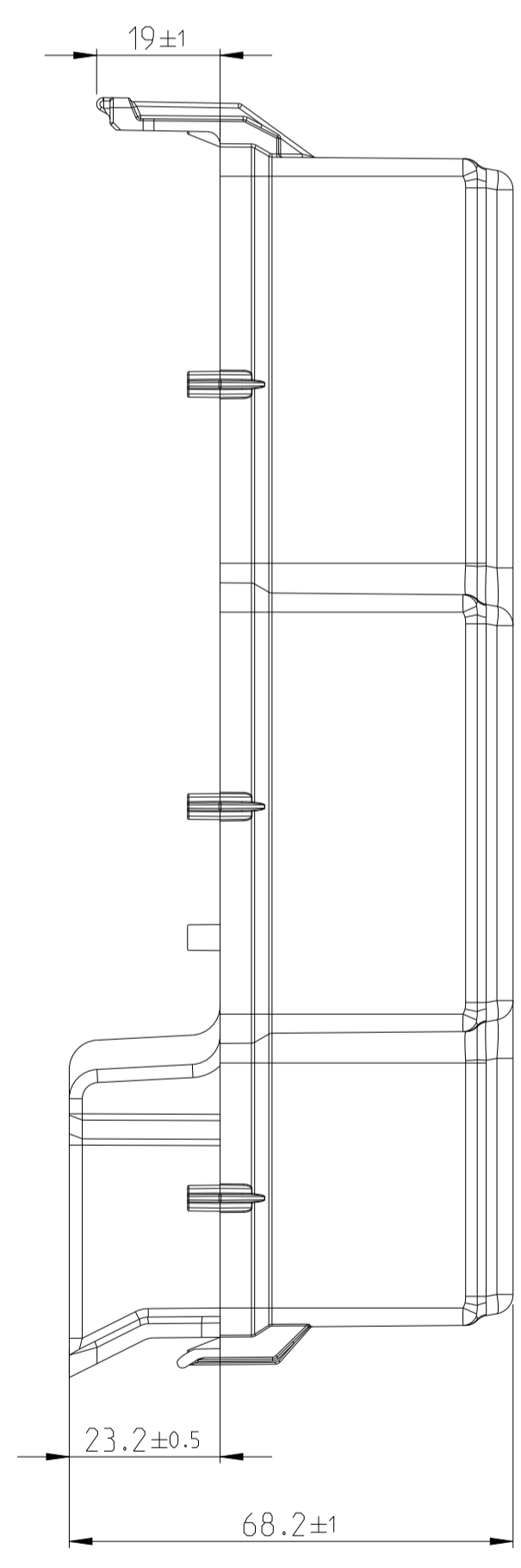
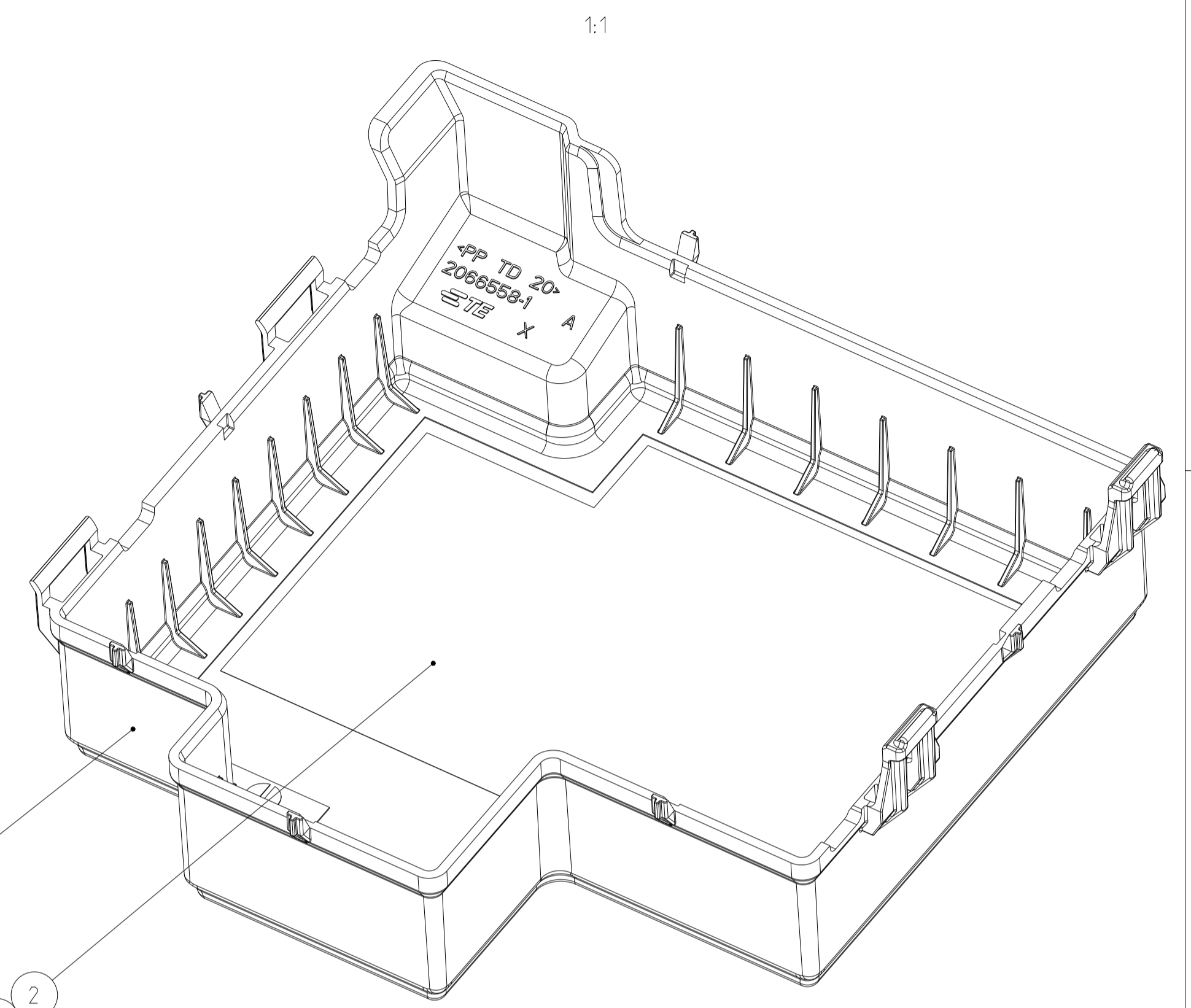
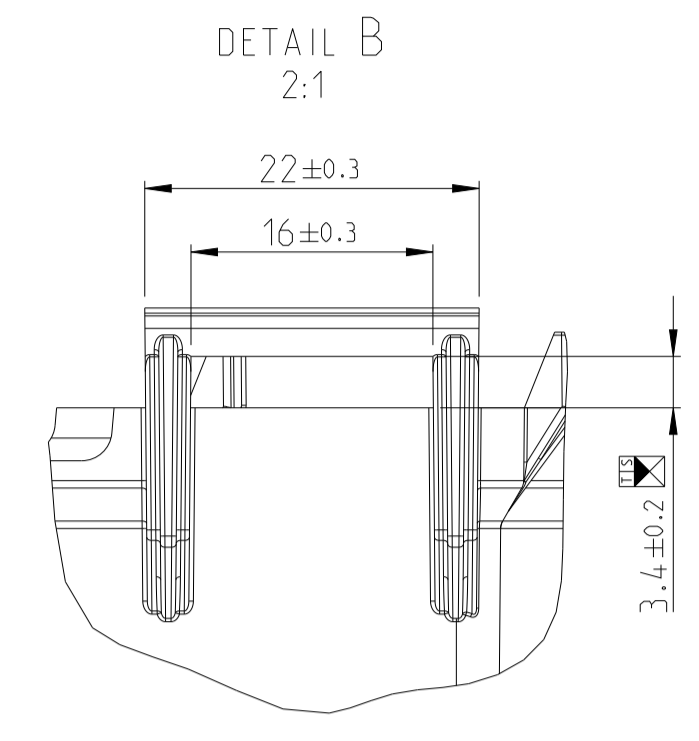
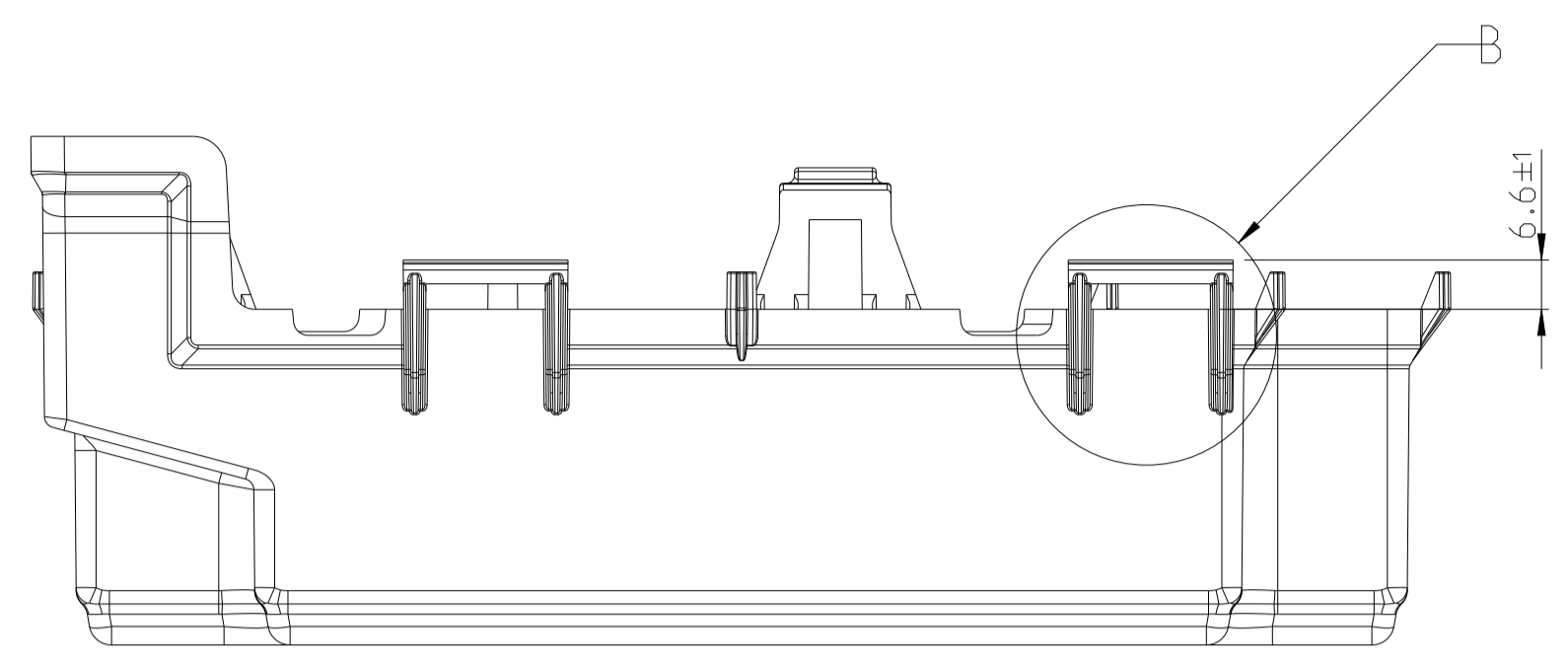

- NOTES:-
- 1 TE LOGO
 - 2 MATERIAL IDENTIFICATION
 - 3 TE PART NO
 - 4 PRODUCTION MONTH CODE
 - 5 PRODUCTION YEAR CODE
 - 6 PART REVISION
 - 7 TOOL CAVITY MARKING
 - 8 15% MAX PERMITTED REGRIND MATERIAL PROCESSED IN CLOSED LOOP
 - 9 QIP Dimension
 - 10 NO AIR BUBBLES ALLOWED ON THE STICKER SURFACE.
 - 11 FOR FUSE AND RELAY PRINTING DETAILS ON THE STICKER, PLEASE REFER M&M STICKER DRAWING NO. 0003AU300050N, 0003AU300230N, 1801AU301630N, 0003AU300031N, 1801AU302530N AND 1801AU303700N

REV	LTN	DESCRIPTION	DATE	OWN	APVD	MATERIAL	COLOR	ITEM NO				
1	0	0	0	0	0	2294154-6	A	E.STICKER.U358 AND U359, WITHOUT BMS	POLYESTER	WHITE	7	
0	1	0	0	0	0	2294154-5	A	STICKER, U358 & U359	POLYESTER	WHITE	6	
0	0	1	0	0	0	2294154-4	A	TUV IP PASSENGER COMPT	POLYESTER	WHITE	5	
0	0	0	1	0	0	2294154-3	A	STICKER, U350 & U352	POLYESTER	WHITE	4	
0	0	0	0	1	0	2294154-2	A	STICKER, U308	POLYESTER	WHITE	3	
0	0	0	0	0	1	2294154-1	A	STICKER, U301	POLYESTER	WHITE	2	
1	1	1	1	1	1	2066558-1	A	TOP COVER, U301	PP TD20%	BLACK	1	
2294162-6	2294162-5	2294162-4	2294162-3	2294162-2	2294162-1	PART NO		REV	DESCRIPTION	MATERIAL	COLOR	ITEM NO
A	A	A	A	A	A	REVISION OF EACH ASSY NO (WHEN BLANK, USE DWG REVISION)						

QTY PER ASSY

PARTS LIST

THIS DRAWING IS A CONTROLLED DOCUMENT.

DIMENSIONS: mm

TOLERANCES UNLESS OTHERWISE SPECIFIED

0 PLC ±

1 PLC ±

2 PLC ±

3 PLC ±

4 PLC ±

ANGLES ±

FINISH

MATERIAL SEE TABLE

OWN: KUNAL G 21JULY2015

CHK: RAJESH K 21JULY2015

APVD: RAMESH K 21JULY2015

NAME: TOP COVER ASSY, ENGINE COMPT FRB

APPLICATION SPEC

SIZE: A1

WEIGHT: 106 gms

CAGE CODE: -

DRAWING NO: C=2294162

CUSTOMER DRAWING

SCALE: 5:1

SHEET: 1 OF 1

REV: A5