

ATLANTIC VERSION TERMINATOR INTERFACE ADAPTER	PART NUMBER	REVISION	DESCRIPTION	FEED TYPE	
	2266632-2	A	FINE CRIMP HEIGHT ADJUST	PNEUMATIC	SUPERSEDED BY 5-2151234-2
	2266632-5	A	FINE CRIMP HEIGHT ADJUST	SERVO LATCH PLATE	OBSOLETE
	2266632-6	A	NON-CRIMP HEIGHT ADJUST	SERVO LATCH PLATE	OBSOLETE
	2266632-7	A	FINE CRIMP HEIGHT ADJUST	NONE	OBSOLETE
	7-2266632-7	A	CRIMP TOOLING KIT	-	

APPLICATOR DATA		
CRIMP	SIZE	TYPE
WIRE	2.03 mm [.080]	F
INSUL	6.35 mm [.250]	O

APPLICATOR INSTRUCTIONS 408-10389

TERMINAL DATA: TE TERMINAL		TE CRIMP SPECIFICATION	
TERMINAL NAME: STANDARD POWER TIMER CONTACT TYPE A			
WIRE STRIP LENGTH		INSULATION DIAMETER RANGE	
4.40-5.00 mm [.173-.197 IN]		Ø	
TERMINAL APPLICATION SPECIFICATION	(A)114-18037		
	(B)114-18388		
TERMINALS APPLIED			
TE TERMINAL	TE TERMINAL	TE SEAL	TE SEAL
(A) 969040-1	(B) 1241412-1	(A) 963243-1	
	(B) 1241412-3		
			INSULATION DIAMETER
			Ø 1.40-2.10

WIRE SIZE	CRIMP HEIGHT mm [INCH]	CRIMP HEIGHT REFERENCE SETTING
1.00mm2	1.61+/-0.05 [1.063+/-0.002]	5.1
0.75mm2	1.52+/-0.05 [1.060+/-0.002]	5.9
0.50mm2	1.43+/-0.05 [1.056+/-0.002]	6.8

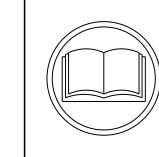

- RECOMMENDED SPARE PARTS
- GREASE BEARING SURFACES LIGHTLY
- 3. LUBRICATE DAILY PER THE APPLICATOR INSTRUCTION SHEET SUPPLIED WITH THE APPLICATOR.
- APPLICATOR SPECIFIC DATA TO BE ENTERED INTO BLANK MEMORY CHIP AT ASSEMBLY. SEE BELOW FOR PART NUMBER:
 PNEUMATIC FEED WITH "SMART APPLICATOR" CONVERSION: 8-2266632-4
 SERVO FEED WITH "FINE CRIMP HEIGHT ADJUST": 8-2266632-5
 SERVO FEED WITH "NON-CRIMP HEIGHT ADJUST": 8-2266632-6
- 5. ADJUSTMENT OF THE STRIPPER MAY BE REQUIRED WHEN MOVING THE APPLICATOR BETWEEN BENCH AND LEADMAKER APPLICATIONS.
- APPLY PART NUMBER 1-23419-5 LOCTITE TO THREADS OF ITEMS 62 & 180. APPLY PART NUMBER 2-23419-6 LOCTITE TO THREADS OF ITEM 242. FOR -6 ONLY APPLY PART NUMBER 1-23419-5 LOCTITE TO THREADS OF ITEMS 37 & 180.
- GREASE THREADS, GROOVE AND O-RING ON ITEMS 35 & 252.
- MAGNET, ITEM 166 MUST BE ORIENTED CORRECTLY IN ORDER TO PROPERLY ACTUATE THE COUNTER.
- CRIMP HEIGHT REFERENCE SETTING WAS THE SETTING USED WHEN THE APPLICATOR WAS QUALIFIED AT THE FACTORY. ADJUSTMENT MAY BE NECESSARY WHEN RUNNING APPLICATOR IN THE FIELD.
- TERMINAL PITCH NOT COMPATIBLE WITH MECHANICAL FEED.
- TO CONVERT THE APPLICATOR TO A NON-CARRIER CUTTING STYLE, REMOVE ITEM 13 AND ATTACH TO THE LOCATION ON THE BACK SIDE OF THE HOUSING. REFER TO INSTRUCTION SHEET FOR ADDITIONAL INFORMATION.
- WHEN ASSEMBLING A NON CRIMP HEIGHT ADJUST APPLICATOR (-6) USE SHIMS FROM ITEM 260 TO ACHIEVE A NOMINAL SHIM HEIGHT OF 4.19.

- THIS APPLICATOR APPLIES TERMINAL WITH A SEAL.
- APPLY TORQ-SEAL IN ALLEN SOCKET TO FILL HOLE AFTER FLAT HD HAS BEEN ADJUSTED TO CORRECT HEIGHT AT QUALIFICATION. APPLY #1-23419-5 LOC-TITE TO THREADS.
- THIS APPLICATOR IS SPECIFIC FOR USE IN A STRIPPER SEAL TERMINATING UNIT.

***WARNING**
 ON INSTALLATION, SET WIRE DISC, ITEM 40 TO LARGEST WIRE SIZE SETTING. USE OF SETTINGS BELOW MINIMUM REQUIRED CRIMP HEIGHT SETTING WILL CAUSE DAMAGE TO CRIMP TOOLING.

-	-	1	-	-	2119957-2	APPLICATOR SHIM PACK	260
-	1	-	1	1	8-21084-0	O-RING, .676 ID, .070 DIA. MAT.	252
-	-	-	-	1	2119640-1	PUSH ROD, AIR FEED	250
-77	-7	-6	-5	-2	PART NO	DESCRIPTION	ITEM NO

ATLANTIC VERSION
 Shown on sheets 1 of 4 & 2 of 4
 (Pacific version shown on sheets 3 of 4 & 4 of 4)

SET UP GAUGE	LOC	DIST	REVISIONS			
2119599-1	A	66	#	DATE	BY	APVD
			A	RELEASED	22JAN2015	BW TE
			A1	ECR-18-008259	29MAY2018	LG JD

-	-	-	-	1	2079988-1	BUSHING, LCH5-12, MISUMI	249
-	-	-	-	1	2119641-1	FEED CAM, AIR FEED	248
-	1	-	1	1	2119798-1	DETENT PIN	247
-	1	-	1	1	1-22279-3	SPRING, COMPRESSION	246
-	-	1	-	-	2119758-1	RAM, AMP STYLE, SIDE FEED, NON-ADJ.	245
	-	1	1	1	2119082-8	CAM, SNAIL, INSULATION ADJUSTMENT	244
-	1	1	1	1	2079764-1	WASHER, WAVE SPRING, CREST-TO-CREST	243
-	1	1	1	1	2119083-1	RETAINER, INSULATION DIAL	242
-	1	1	1	1	7-18023-7	SCR, SKT HD CAP M3 X 4.0	241
-	-	2	2	-	2168400-6	SHCS, LOW HEAD, RoHS, M5 X 16	240
-	-	-	-	-	2119580-1	MECHANICAL FEED ASSEMBLY	239
-	-	-	-	1	2063440-1	AIR FEED MODULE	238
	-	-	1	1	2119740-2	TAG, IDENTIFICATION	213
-	-	1	1	-	1901094-3	SPACER, FEEDER	198
-	1	1	1	1	2-1752354-2	STANDOFF, HOLD-DOWN	180
-	1	1	1	1	9931111-1	PIN, SLOTTED SPRING 3.0 X 20.0	177
-	1	1	1	1	5-22280-0	SPRING, COMPRESSION	176
-	1	1	1	1	1752353-3	GUIDE PIN, HOLDDOWN	175
-	1	1	1	1	1901680-2	GUIDE PIN, HOLDDOWN	174
-	-	-	-	2	21045-3	RING, RETAIN, EXTERN, 3/16 CRESCENT	172
-	1	1	1	1	994969-1	MAGNET, RARE EARTH HIGH ENERGY	166
-	REF	REF	REF	REF	994970-2	COUNTER, MAGNETIC	164
-	-	-	-	1	240638-1	SPRING, FEED FINGER	163
-	-	-	-	1	3-23627-7	PIN, RETAIN, GRVD, 3/16 X .854	137
-	-	-	-	1	2119799-1	HOLDER, FEED FINGER, AF	136
-	-	REF	REF	-	SEE NOTE 4	MEMORY CHIP, PROGRAMMED	135
-	-	1	1	-	1633743-1	SERVO FEED LATCH ASM	133
-	-	REF	REF	-	2119944-1	FEED FINGER ASSEMBLY, SF	117
-	1	1	1	1	455888-5	SPACER, CRIMPER	82
-	1	1	1	1	2119956-1	DOCUMENTATION PACKAGE	71
-	1	-	-	1	2119740-1	TAG, IDENTIFICATION	67
	-	2	2	2	2168078-1	SCREW, DRIVE, RH, RoHS, 2 x .188	66
-	1	-	1	1	2119793-1	LIMITER, ADJUSTMENT BOLT	63
-	3	-	3	3	992763-5	SCR, SET, SOC, CONE PNT, M3 X 4.0	62
-	1	1	1	1	2079383-4	SCR, BHSC, RoHS (M4 X 8)	60
-	-	-	-	1	5-18022-5	SCR, HEX HD CAP, M4 X 6.0	59
-	1	1	1	1	985575-3	SCR, FLT SKT HD CAP M3 X 10.0	57
-	-	-	-	1	1338683-8	FEED PAWL	56
-	4	4	4	4	2168400-1	SHCS, LOW HEAD, RoHS, M4 X 12	54
-	1	1	1	1	1-5018030-0	NUT, HEX, REG, RoHS, M3.5	52
-	1	1	1	1	4-1722335-3	STRIPPER, SIDE FEED	51
-	-	-	-	1	18023-9	SCR, SKT HD CAP M4 X 6.0	49
-	-	-	-	-	2119652-1	FEED CAM, PRE FEED	48
-	-	-	-	-	2119653-1	FEED CAM, POST FEED	47
-	1	1	1	1	2-2119656-1	APPLICATOR BASIC ASSEMBLY, SF	46
-	1	-	1	1	2119370-1	RAM, AMP STYLE, SIDE FEED	44
-	1	1	1	1	2079383-7	SCR, BHSC, RoHS (M8 X 25)	41
-	1	-	1	1	2119645-1	DISC, NUMBERED FA WIRE ADJUSTMENT	40
	-	1	-	1	2119957-1	APPLICATOR SHIM PACK	39
-	1	1	1	1	1-2119644-2	RAM WASHER, PRECISION	38
-	1	1	1	1	2119085-1	FA HEAD, ATLANTIC STYLE	37
-	1	-	1	1	2119092-1	BOLT, ADJUSTMENT	35
-	1	1	1	1	1-1752356-1	SUPPORT, TERMINAL	34
-	2	2	2	2	2079383-5	SCR, BHSC, RoHS (M4 X 20)	33
-	1	1	1	1	2161328-1	HEX HEAD, FLANGED, M5 X 8mm LONG	32
-	1	1	1	1	1320908-7	SPACER, STRIP GUIDE	30
-	1	1	1	1	2119959-2	ASSEMBLY, STRIP GUIDE	29
-	1	1	1	1	455888-3	SPACER, CRIMPER	28
-	1	1	1	1	1320928-6	STRIP GUIDE	24
-	1	1	1	1	1-18028-2	WASHER, FLAT, REG M4	20
	-	1	1	1	2119806-1	INSERT, SHEAR	13
-	1	1	1	1	3-22280-3	SPRING, COMPRESSION	12
-	1	1	1	1	1-356885-4	STOP, SHEAR	11
	-	1	1	1	2119805-1	SHEAR HOLDER, FRONT	10
	-	1	1	1	318707-1	FLOATING SHEAR, FRONT	9
	1	1	1	1	4-1333204-2	ANVIL, COMBINATION	8
-	-	-	-	-	-	-	7
-	-	-	-	-	-	-	6
-	1	1	1	1	2-2119781-4	DEPRESSOR, SHEAR	5
-	1	1	1	1	238011-2	BLOCK, CRIMPER SPACER	4
	1	1	1	1	1633996-6	CRIMPER, INSULATION SPECIAL	3
-	1	1	1	1	455888-9	SPACER, CRIMPER	2
	1	1	1	1	1-456405-6	CRIMPER, WIRE PREMIUM	1
-77	-7	-6	-5	-2	PART NO	DESCRIPTION	ITEM NO

DIMENSIONS:		TOLERANCES UNLESS OTHERWISE SPECIFIED:		DRAWING NO.		NAME	
mm	0 PLC ±.5	1 PLC ±0.5	2 PLC ±0.13	3 PLC ±0.013	4 PLC ±0.0001	ANGLES ±.1	FINISH
MATERIAL				WEIGHT		SCALE	
Customer Accessible Production Drawing				SCALE 1:2		SHEET 1 of 4 REV A1	

STE TE Connectivity
 Harrisburg, PA 17105-3608

Ocean Side Feed
 Applicator

SIZE CAGE CODE DRAWING NO. RESTRICTED TO
 A1 00779 ©=2266632

LOC		DIST		REVISIONS			
A		66		REV	DATE	OWN	APVD
-				1	SEE SHEET 1	-	-

FEED TYPE

PNEUMATIC

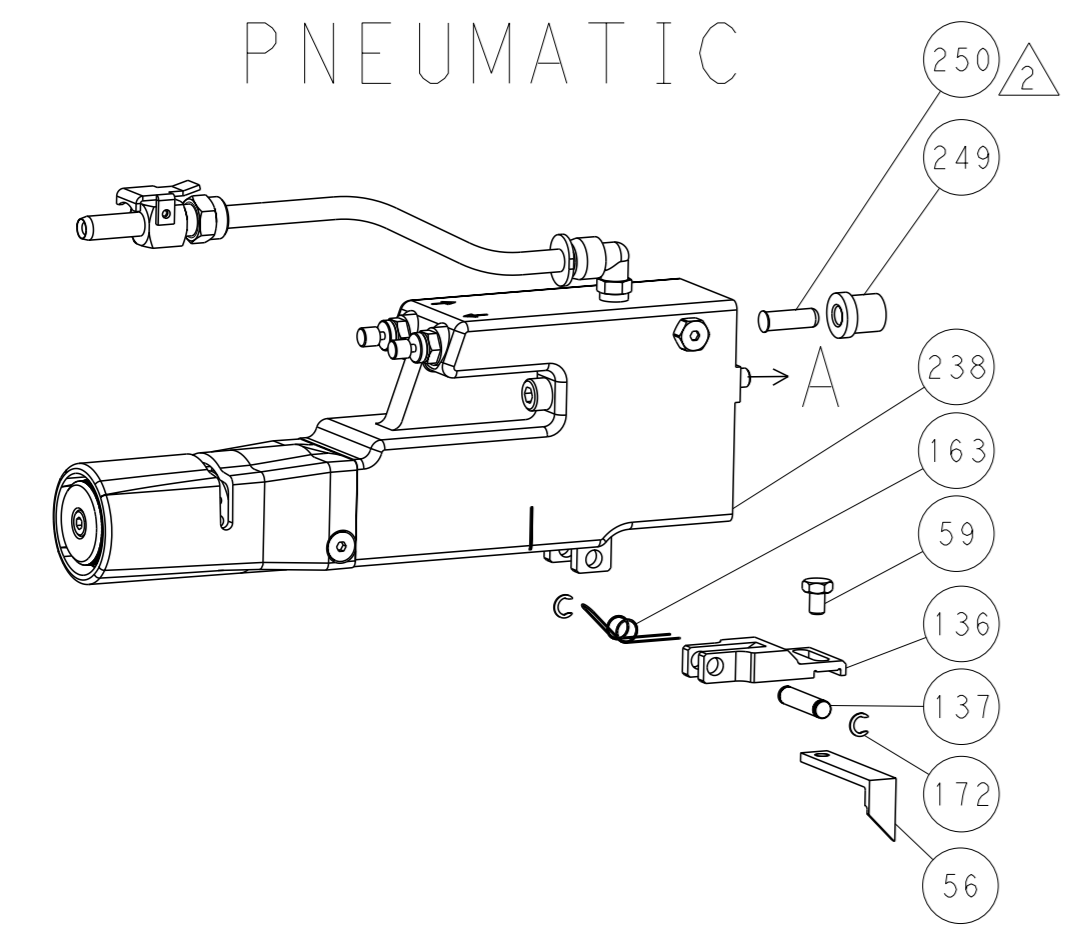

SERVO LATCH PLATE

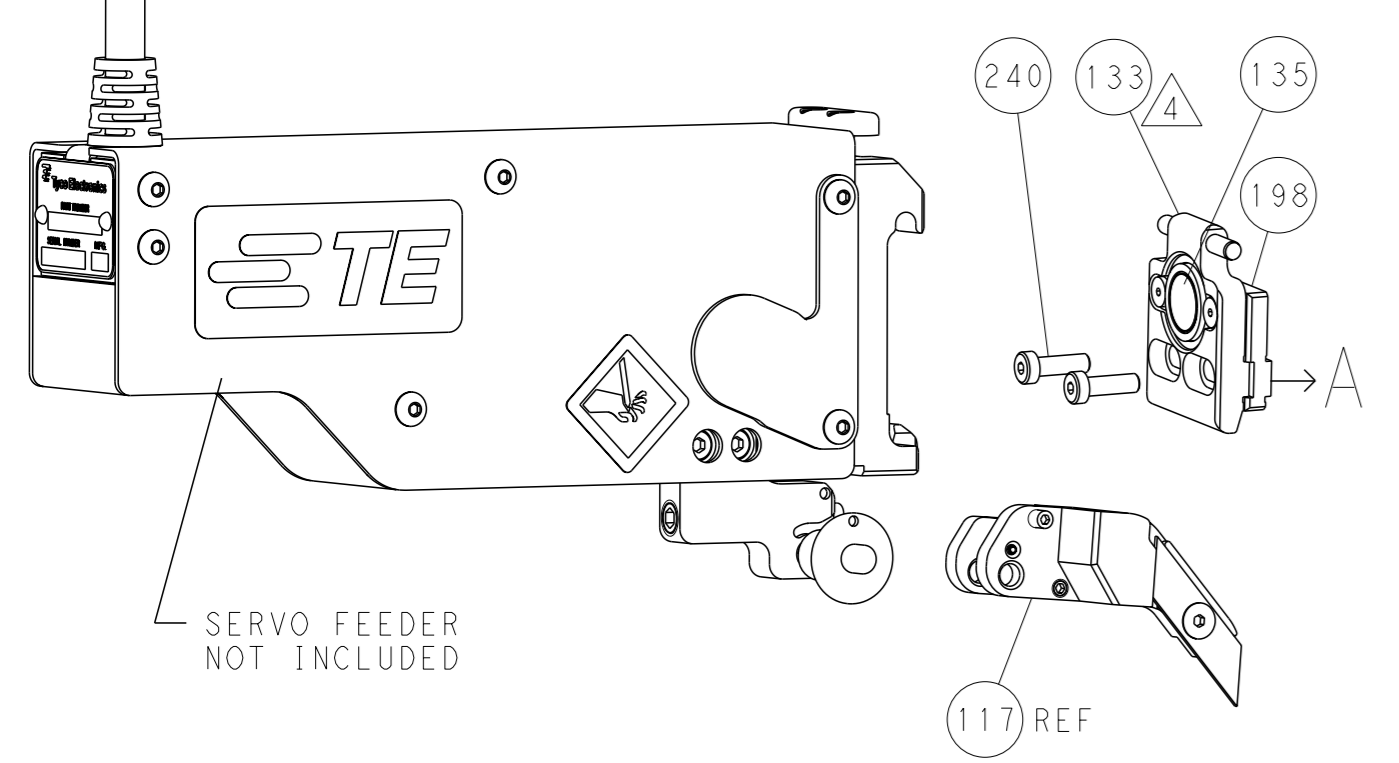

CAM POSITION

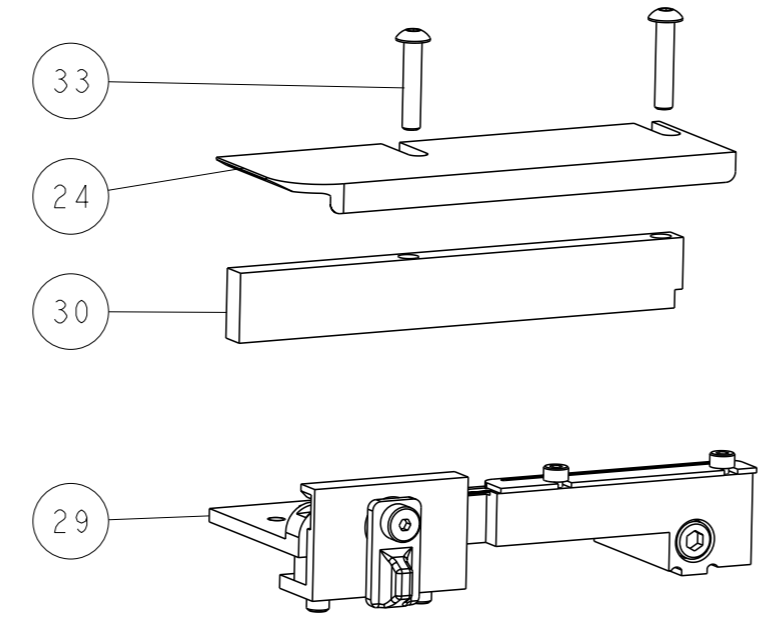
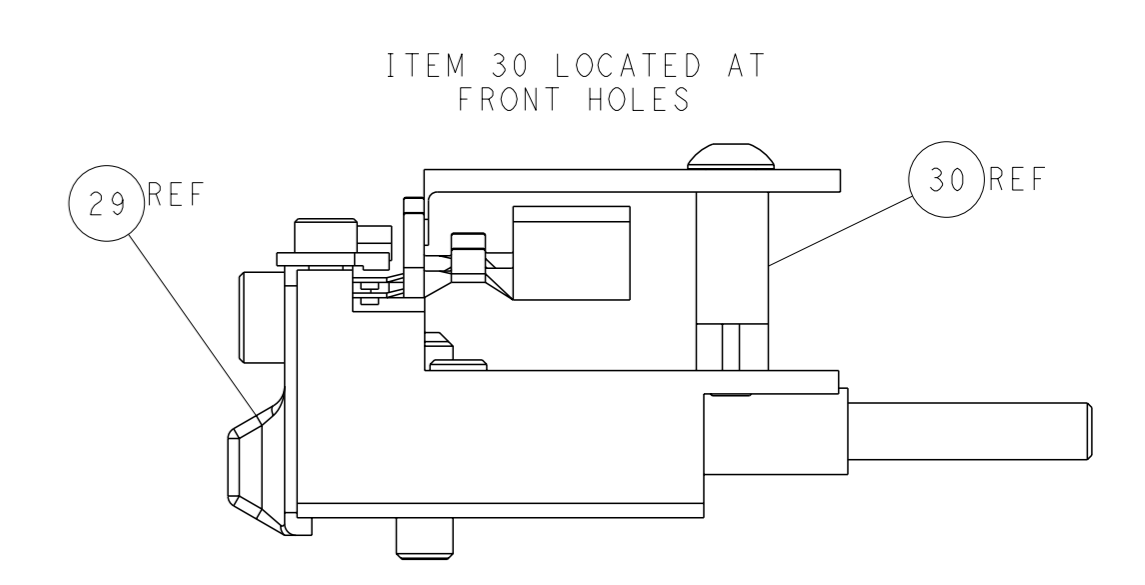
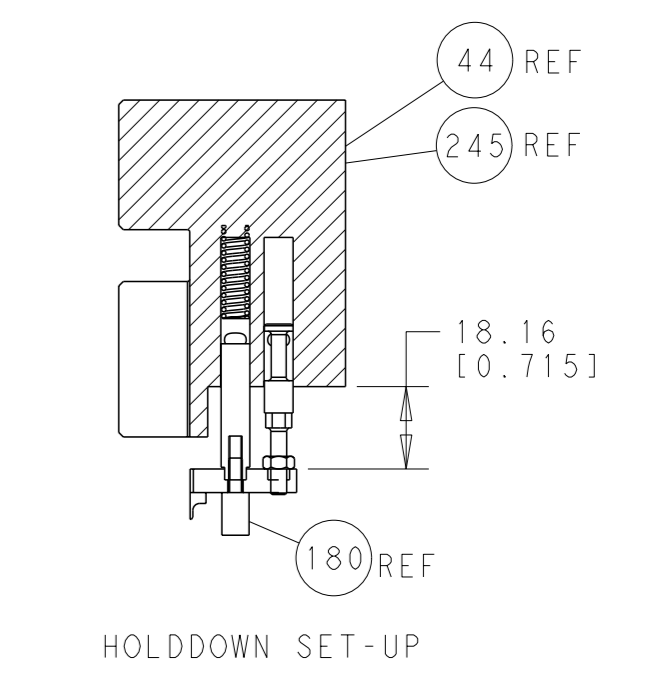
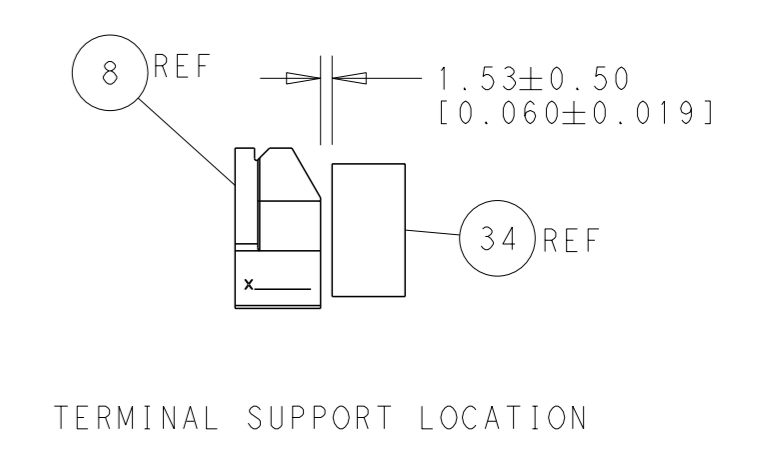
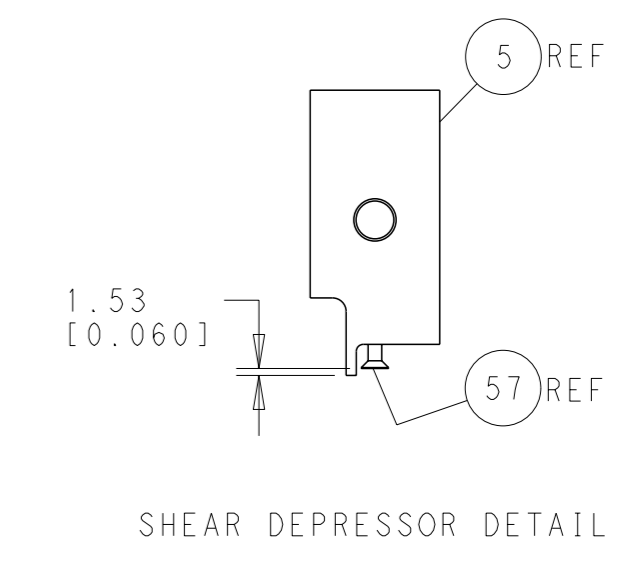
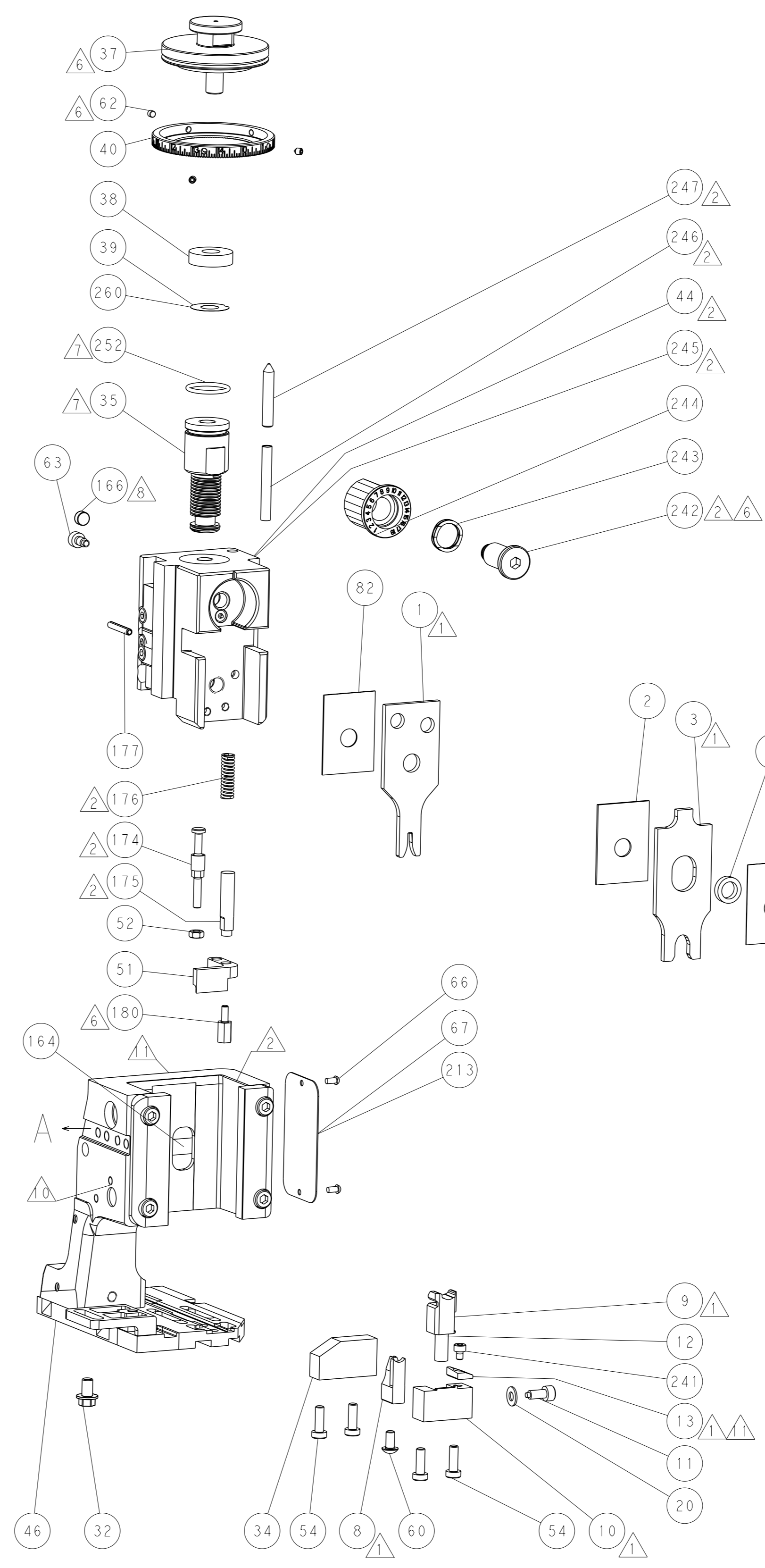
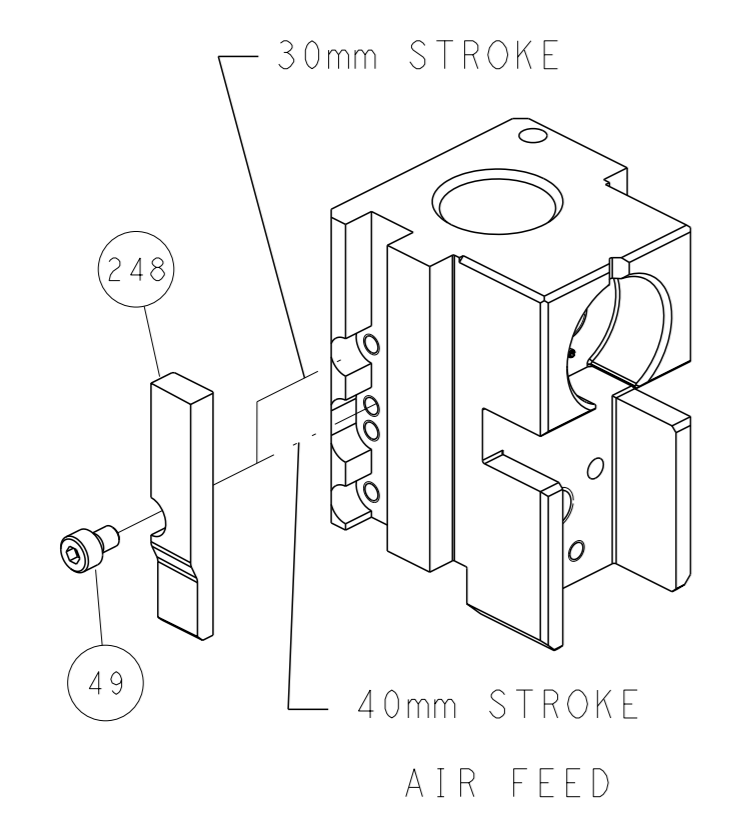

ATLANTIC VERSION
 Shown on sheets 1 of 4 & 2 of 4
 (Pacific version shown on sheets 3 of 4 & 4 of 4)

DIMENSIONS: mm 		TOLERANCES UNLESS OTHERWISE SPECIFIED: 0 PLC ±.5 1 PLC ±0.13 2 PLC ±0.13 3 PLC ±0.013 4 PLC ±0.001 ANGLES FINISH ±.		OWN: B. WEAVER 16DEC2014 CHK: T. ELBIN 16DEC2014 APVD: T. ELBIN 16DEC2014 PRODUCT SPEC: - APPLICATION SPEC: - WEIGHT: - MATERIAL: -		NAME: Ocean Side Feed Applicator SIZE: A1 CAGE CODE: 00779 DRAWING NO: C=2266632 SCALE: 1:2 SHEET: 2 of 4 REV: A1		TE Connectivity Harrisburg, PA 17105-3608	
Customer Accessible Production Drawing				RESTRICTED TO		SHEETS 3 & 4 ARE NOT REQUIRED FOR ATLANTIC VERSION			

PACIFIC VERSION TERMINATOR INTERFACE ADAPTER	PART NUMBER	REVISION	DESCRIPTION	FEED TYPE	
	2-2266632-2	A	FINE CRIMP HEIGHT ADJUST	PNEUMATIC	OBSOLETE
	2-2266632-5	A	FINE CRIMP HEIGHT ADJUST	SERVO LATCH PLATE ⁴	OBSOLETE
	2-2266632-7	A	FINE CRIMP HEIGHT ADJUST	NONE	OBSOLETE
	7-2266632-7	A	CRIMP TOOLING KIT	-	

APPLICATOR DATA		
CRIMP WIRE	SIZE	TYPE
INSUL	6.35 mm [.250]	O
APPLICATOR INSTRUCTIONS 408-10389		

TERMINAL DATA: TE TERMINAL		TE CRIMP SPECIFICATION	
TERMINAL NAME: STANDARD POWER TIMER CONTACT TYPE A			
WIRE STRIP LENGTH		INSULATION DIAMETER RANGE	
4.40-5.00 mm [.173-.197 IN]		∅	-
TERMINAL APPLICATION SPECIFICATION	(A)114-18037		
	(B)114-18388		
TERMINALS APPLIED ¹⁰			
TE TERMINAL	TE TERMINAL	TE SEAL	TE SEAL
(A) 969040-1	(B) 1241412-1	(A) 963243-1	
	(B) 1241412-3		
			INSULATION DIAMETER
			∅1.40-2.10

WIRE SIZE	CRIMP HEIGHT mm [INCH]	CRIMP HEIGHT REFERENCE SETTING
1.00mm2	1.61 +/- 0.05 [.063 +/- .002]	5.1
0.75mm2	1.52 +/- 0.05 [.060 +/- .002]	5.9
0.50mm2	1.43 +/- 0.05 [.056 +/- .002]	6.8

***WARNING**
 ON INSTALLATION, SET WIRE DISC, ITEM 40 TO LARGEST WIRE SIZE SETTING. USE OF SETTINGS BELOW MINIMUM REQUIRED CRIMP HEIGHT SETTING WILL CAUSE DAMAGE TO CRIMP TOOLING.

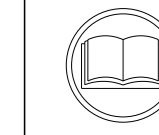

- ¹ RECOMMENDED SPARE PARTS
- ² GREASE BEARING SURFACES LIGHTLY
- 3. LUBRICATE DAILY PER THE APPLICATOR INSTRUCTION SHEET SUPPLIED WITH THE APPLICATOR.
- ⁴ APPLICATOR SPECIFIC DATA TO BE ENTERED INTO BLANK MEMORY CHIP AT ASSEMBLY. SEE BELOW FOR PART NUMBER:
 PNEUMATIC FEED WITH "SMART APPLICATOR" CONVERSION: 8-2266632-4
 SERVO FEED WITH "FINE CRIMP HEIGHT ADJUST": 8-2266632-5
- 5. ADJUSTMENT OF THE STRIPPER MAY BE REQUIRED WHEN MOVING THE APPLICATOR BETWEEN BENCH AND LEADMAKER APPLICATIONS.
- ⁶ APPLY PART NUMBER 1-23419-5 LOCTITE TO THREADS OF ITEMS 62 & 180. APPLY PART NUMBER 2-23419-6 LOCTITE TO THREADS OF ITEM 242.
- ⁷ GREASE THREADS, GROOVE AND O-RING ON ITEMS 139 & 152.
- ⁸ MAGNET MUST BE ORIENTED CORRECTLY IN ORDER TO PROPERLY ACTUATE THE COUNTER.
- ⁹ CRIMP HEIGHT REFERENCE SETTING WAS THE SETTING USED WHEN THE APPLICATOR WAS QUALIFIED AT THE FACTORY. ADJUSTMENT MAY BE NECESSARY WHEN RUNNING APPLICATOR IN THE FIELD.
- ¹⁰ TERMINAL PITCH NOT COMPATIBLE WITH MECHANICAL FEED.
- ¹¹ TO CONVERT THE APPLICATOR TO A NON-CARRIER CUTTING STYLE, REMOVE ITEM 13 AND ATTACH TO THE LOCATION ON BACK SIDE OF THE HOUSING. REFER TO INSTRUCTION SHEET FOR ADDITIONAL INFORMATION.

- ¹² THIS APPLICATOR APPLIES TERMINAL WITH A SEAL.
- ¹³ APPLY TORO-SEAL IN ALLEN SOCKET TO FILL HOLE AFTER FLAT HD HAS BEEN ADJUSTED TO CORRECT HEIGHT AT QUALIFICATION. APPLY #1-23419-5 LOC-TITE TO THREADS.
- ¹⁴ THIS APPLICATOR IS SPECIFIC FOR USE IN A STRIPPER SEAL TERMINATING UNIT.

-77	-27	-25	-22	PART NO	DESCRIPTION	ITEM NO
-	1	1	1	2119782-1	FINE ADJUST HEAD ASM, PACIFIC STYLE	251

PACIFIC VERSION
 Shown on sheets 3 of 4 & 4 of 4
 (Atlantic version shown on sheets 1 of 4 & 2 of 4)

SET UP GAUGE	LOC	DIST	REVISIONS			
2119599-1	A	66	#	DATE	OWN	APVD
			-	SEE SHEET 1	-	-

-	-	-	1	2119640-1	PUSH ROD, AIR FEED	250
-	-	-	1	2079988-1	BUSHING, LCH5-12, MISUMI	249
-	1	1	1	1-22279-3	SPRING, COMPRESSION	246
⁶	-	1	1	2119082-8	CAM, SNAIL, INSULATION ADJUSTMENT	244
-	1	1	1	2079764-1	WASHER, WAVE SPRING, CREST-TO-CREST	243
-	1	1	1	2119083-1	RETAINER, INSULATION DIAL	242
-	1	1	1	7-18023-7	SCR, SKT HD CAP M3 X 4.0	241
-	-	2	-	2168400-6	SHCS, LOW HEAD, RoHS, M5 X 16	240
-	-	-	-	2119580-1	MECHANICAL FEED ASSEMBLY	239
-	-	-	1	2063440-1	AIR FEED MODULE	238
⁶	-	-	1	2119740-2	TAG, IDENTIFICATION	213
-	-	1	-	1901094-3	SPACER, FEEDER	198
-	1	1	1	2-1752354-2	STANDOFF, HOLD-DOWN	180
-	1	1	1	9931111-1	PIN, SLOTTED SPRING 3.0 X 20.0	177
-	1	1	1	5-22280-0	SPRING, COMPRESSION	176
-	1	1	1	1752353-3	GUIDE PIN, HOLDDOWN	175
-	1	1	1	1901680-2	GUIDE PIN, HOLDDOWN	174
-	-	-	2	21045-3	RING, RETAIN, EXTERN, 3/16 CRESCENT	172
-	1	1	1	994969-1	MAGNET, RARE EARTH HIGH ENERGY	166
-	REF	REF	REF	994970-2	COUNTER, MAGNETIC	164
-	-	-	1	240638-1	SPRING, FEED FINGER	163
-	1	1	1	8-21084-1	O-RING, .801 ID, .070 DIA. MAT.	152
-	-	-	1	2119641-2	FEED CAM, AIR FEED	151
-	1	1	1	2119798-2	DETENT PIN	145
-	1	1	1	2079383-8	SCR, BHSC, RoHS (M4 X 16)	144
-	4	4	4	2168400-5	SHCS, LOW HEAD, RoHS, M4 X 20	143
-	-	-	-	2119653-2	FEED CAM, POST FEED	142
-	1	1	1	2-2119656-2	APPLICATOR BASIC ASSEMBLY, SF	141
-	1	1	1	2119650-1	RAM, ASIAN STYLE, SIDE FEED	140
-	1	1	1	2119092-2	BOLT, ADJUSTMENT	139
-	-	-	1	3-23627-7	PIN, RETAIN, GRVD, 3/16 X .854	137
-	-	-	1	2119799-1	HOLDER, FEED FINGER, AF	136
-	-	REF	-	SEE NOTE 4	MEMORY CHIP, PROGRAMMED	135
-	-	1	-	1633743-1	SERVO FEED LATCH ASM	133
-	-	REF	-	2119944-1	FEED FINGER ASSEMBLY, SF	117
-	1	1	1	455888-5	SPACER, CRIMPER	82
-	1	1	1	2119956-1	DOCUMENTATION PACKAGE	71
-	1	-	1	2119740-1	TAG, IDENTIFICATION	67
⁶	-	2	2	2168078-1	SCREW, DRIVE, RH, RoHS, 2 x .188	66
-	1	1	1	2119793-1	LIMITER, ADJUSTMENT BOLT	63
-	3	3	3	992763-5	SCR, SET, SOC, CONE PNT, M3 X 4.0	62
-	-	-	1	5-18022-5	SCR, HEX HD CAP, M4 X 6.0	59
-	1	1	1	985575-3	SCR, FLT SKT HD CAP M3 X 10.0	57
-	-	-	1	1338683-8	FEED PAWL	56
-	1	1	1	1-5018030-0	NUT, HEX, REG, RoHS, M3.5	52
-	1	1	1	4-1722335-3	STRIPPER, SIDE FEED	51
-	-	-	1	18023-9	SCR, SKT HD CAP M4 X 6.0	49
-	-	-	-	2119652-1	FEED CAM, PRE FEED	48
-	1	1	1	2079383-7	SCR, BHSC, RoHS (M8 X 25)	41
-	1	1	1	2119645-1	DISC, NUMBERED FA WIRE ADJUSTMENT	40
-	1	1	1	2119957-1	APPLICATOR SHIM PACK	39
-	1	1	1	1-2119644-2	RAM WASHER, PRECISION	38
-	1	1	1	1-1752356-1	SUPPORT, TERMINAL	34
-	2	2	2	2079383-5	SCR, BHSC, RoHS (M4 X 20)	33
-	1	1	1	2161328-1	HEX HEAD, FLANGED, M5 X 8mm LONG	32
-	1	1	1	1320908-7	SPACER, STRIP GUIDE	30
-	1	1	1	2119959-2	ASSEMBLY, STRIP GUIDE	29
-	1	1	1	455888-3	SPACER, CRIMPER	28
-	1	1	1	1320928-6	STRIP GUIDE	24
-	1	1	1	1-18028-2	WASHER, FLAT, REG M4	20
¹	-	1	1	2119806-1	INSERT, SHEAR	13
-	1	1	1	3-22280-3	SPRING, COMPRESSION	12
-	1	1	1	1-356885-4	STOP, SHEAR	11
¹	-	1	1	2119805-1	SHEAR HOLDER, FRONT	10
¹	-	1	1	318707-1	FLOATING SHEAR, FRONT	9
¹	1	1	1	4-1333204-2	ANVIL, COMBINATION	8
-	-	-	-	-	-	7
-	-	-	-	-	-	6
-	1	1	1	2-2119781-4	DEPRESSOR, SHEAR	5
-	1	1	1	238011-2	BLOCK, CRIMPER SPACER	4
¹	1	1	1	1633996-6	CRIMPER, INSULATION SPECIAL	3
-	1	1	1	455888-9	SPACER, CRIMPER	2
¹	1	1	1	1-456405-6	CRIMPER, WIRE PREMIUM	1

DIMENSIONS:		TOLERANCES UNLESS OTHERWISE SPECIFIED: 0 PLC ±.5 2 PLC ±0.5 3 PLC ±0.13 4 PLC ±0.001 ANGLES FINISH ±.		OWN: B. WEAVER 16DEC2014 CHK: T. ELBIN 16DEC2014 APVD: T. ELBIN 16DEC2014	NAME: Ocean Side Feed Applicator SIZE: A1 CASE CODE: 00779 DRAWING NO: C=2266632 RESTRICTED TO: -
MATERIAL: -		WEIGHT: -		Customer Accessible Production Drawing	
		SCALE: 1:2		SHEET 3 of 4	

LOC	DIST	REVISIONS			
A	66	REV	DATE	OWN	APVD
-	SEE SHEET 1	-	-	-	-

FEED TYPE PNEUMATIC

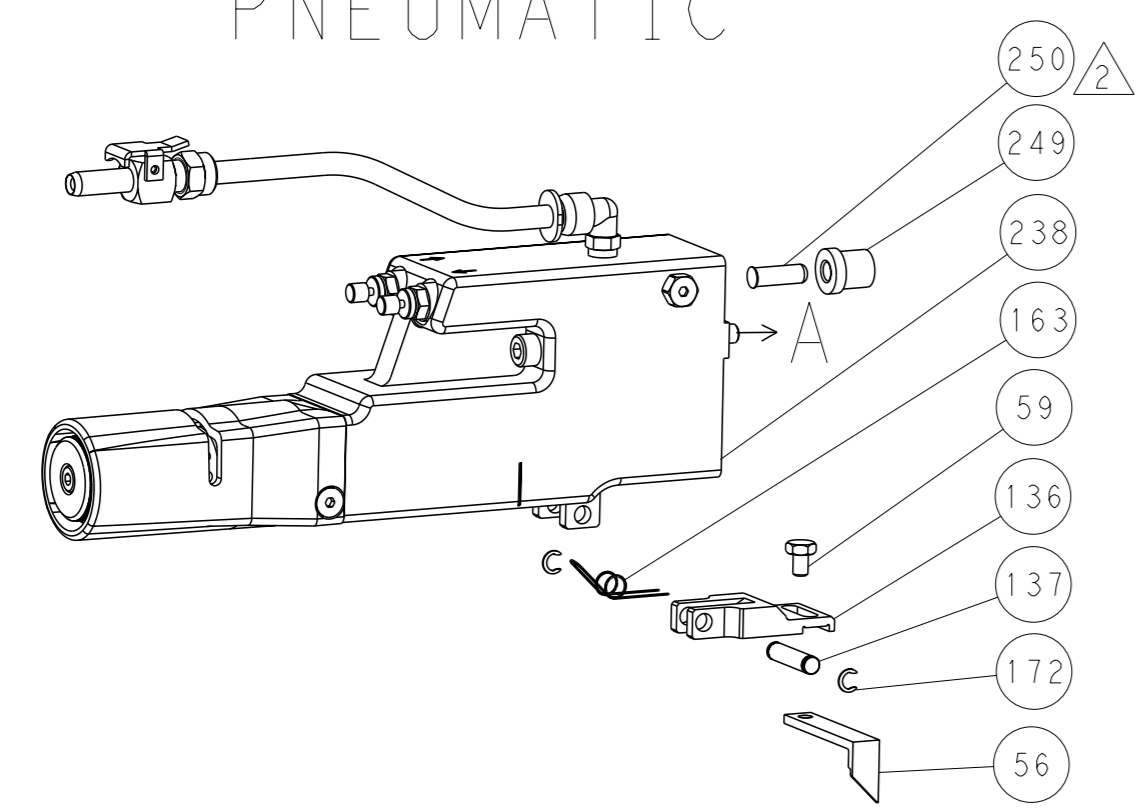

SERVO LATCH PLATE

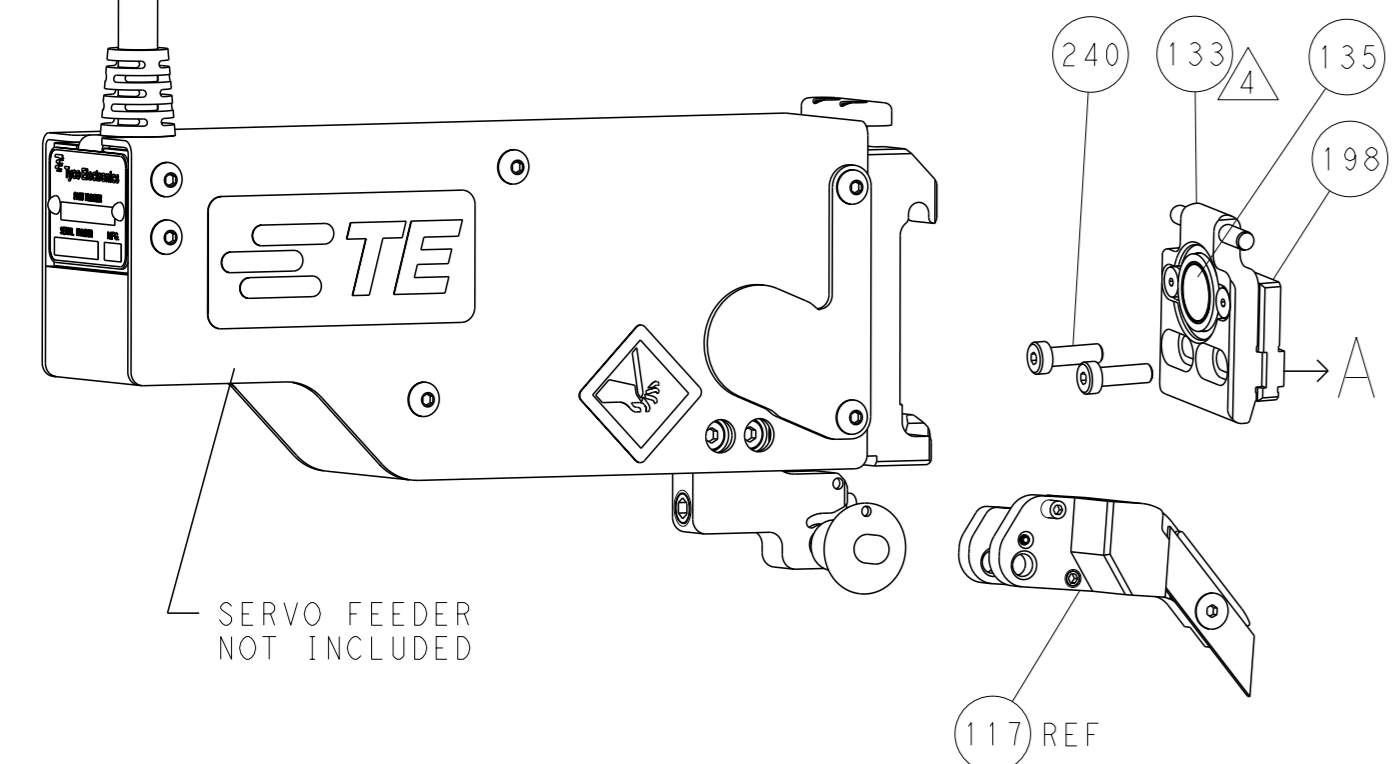

CAM POSITION

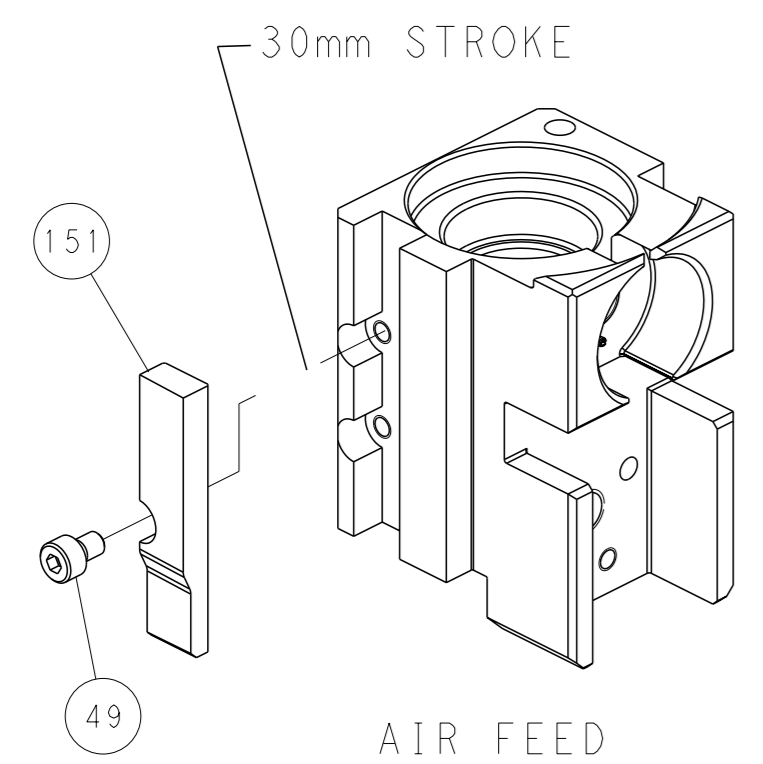

AIR FEED

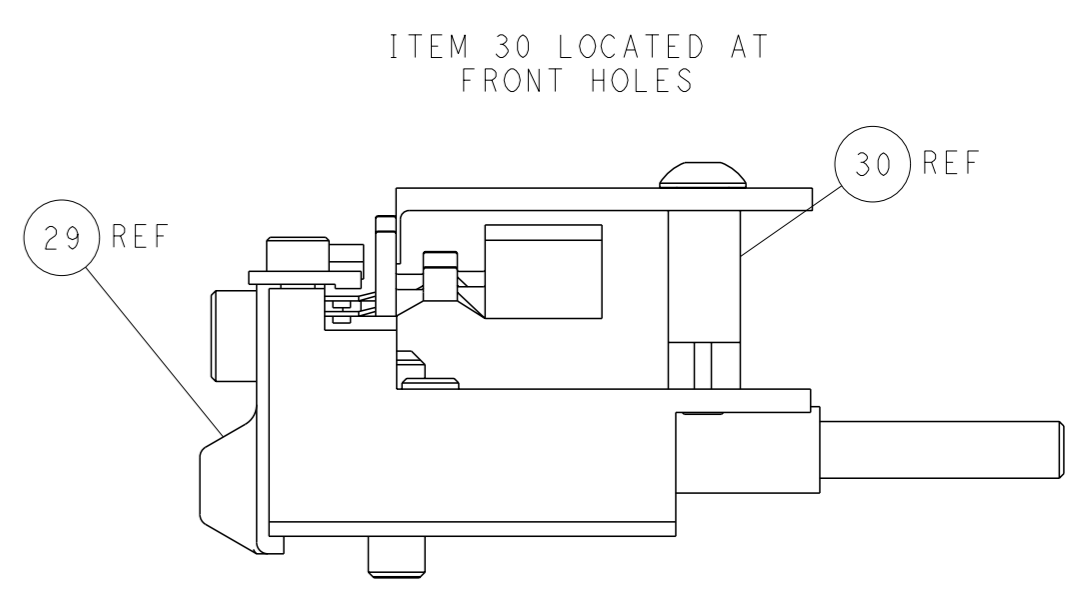
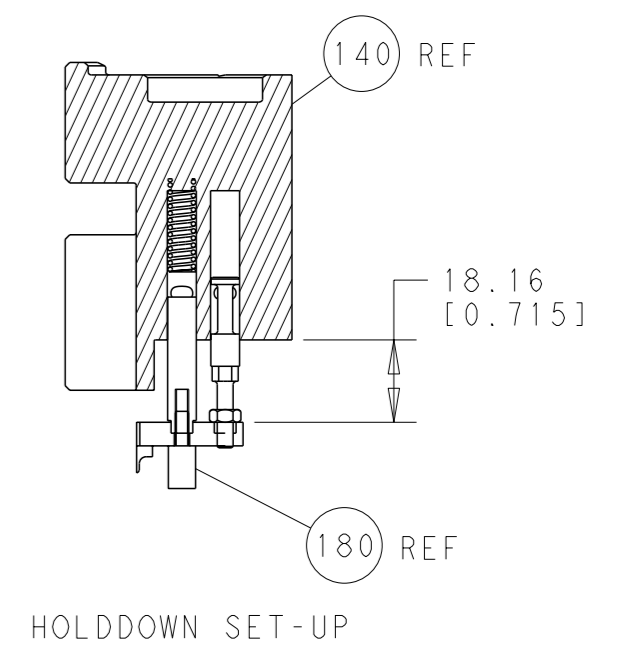
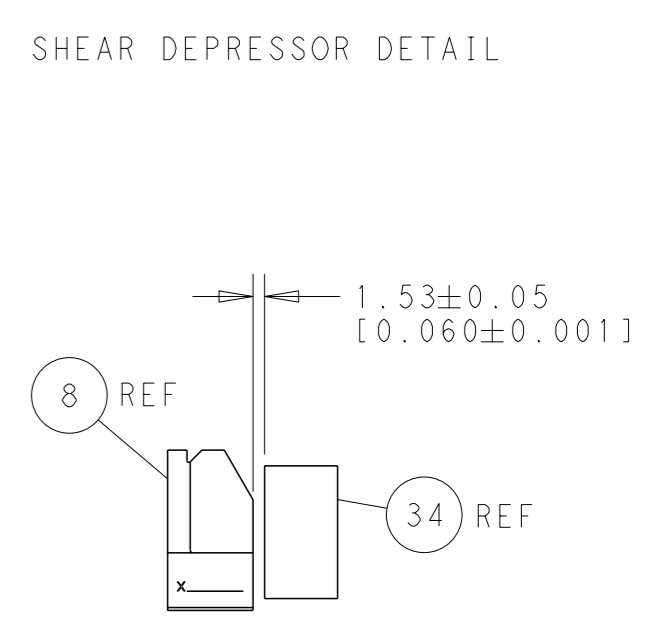
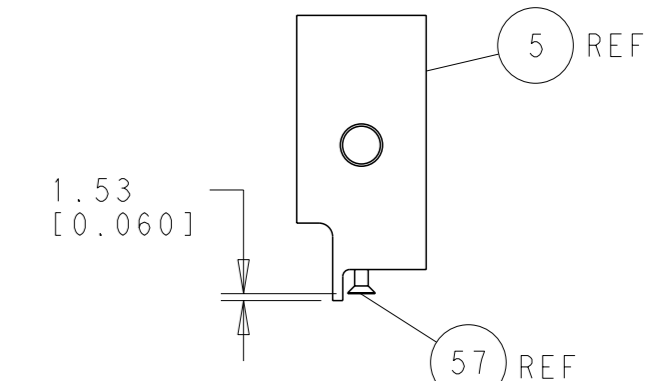
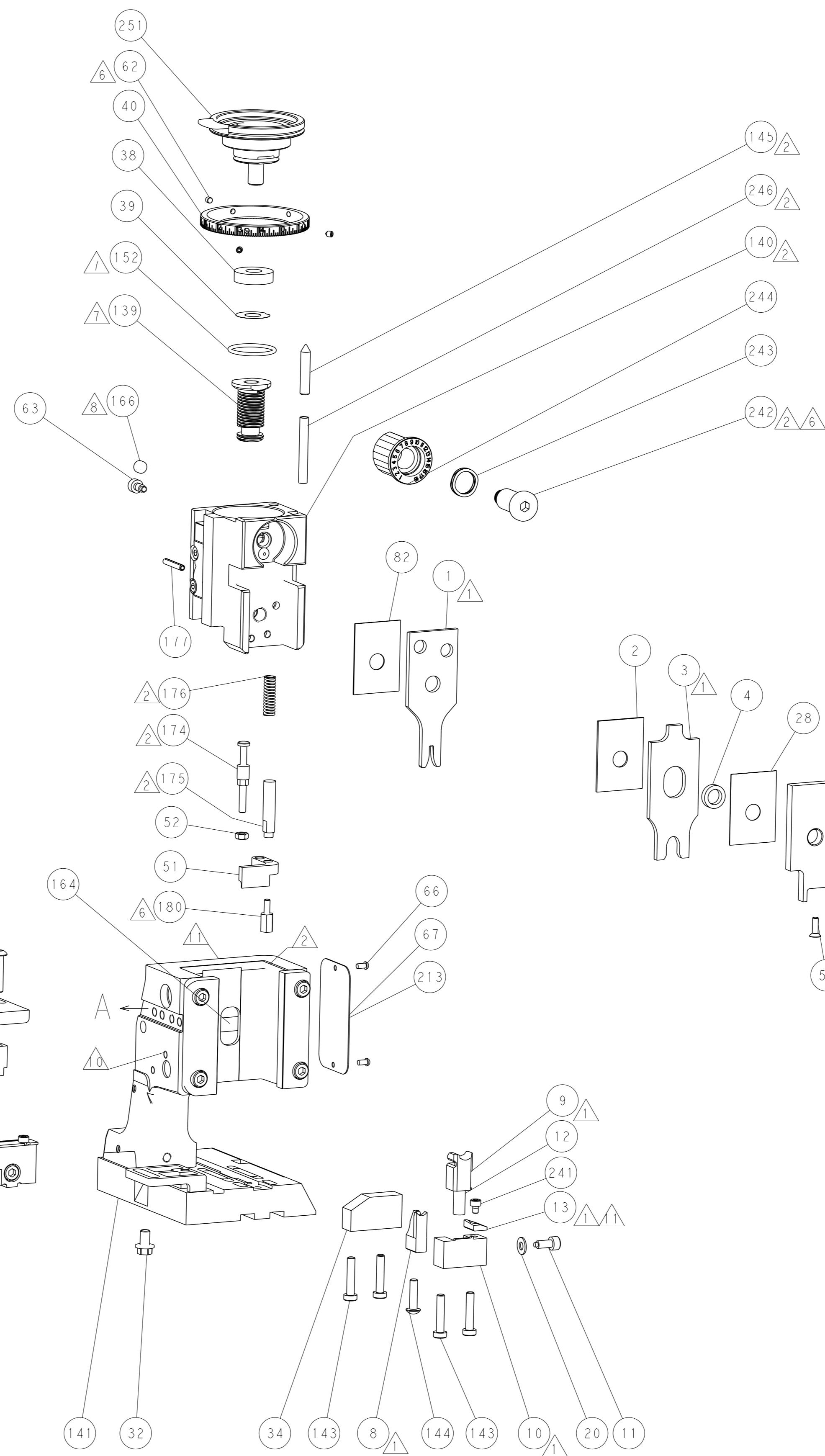

FEED TRACK POSITION
GUIDE BY INSULATION BARREL

PACIFIC VERSION
 Shown on sheets 3 of 4 & 4 of 4
 (Atlantic version shown on sheets 1 of 4 & 2 of 4)

<small>THIS DRAWING IS A CONTROLLED DOCUMENT FOR TYCO ELECTRONICS CORPORATION. IT IS SUBJECT TO CHANGE AND THE CONTROLLER ENGINEERING ORGANIZATION SHOULD BE CONTACTED FOR THE LATEST REVISION.</small>		DWN: B. WEAVER 16DEC2014 CHK: T. ELBIN 16DEC2014 APVD: T. ELBIN 16DEC2014	TE Connectivity Harrisburg, PA 17105-3608
DIMENSIONS: mm 	TOLERANCES UNLESS OTHERWISE SPECIFIED: 0 PLC ±.5 1 PLC ±0.13 2 PLC ±0.13 3 PLC ±0.013 4 PLC ±0.0001 ANGLES FINISH ±.	NAME: Ocean Side Feed Applicator PRODUCT SPEC: APPLICATION SPEC: WEIGHT: SCALE: 1:2	SIZE: A1 CAGE CODE: 00779 DRAWING NO: C=2266632 SHEET: 4 of 4 REV: A1
MATERIAL:		Customer Accessible Production Drawing	