

PART NUMBER	REVISION	DESCRIPTION	FEED TYPE
2266102-1	D	FINE CRIMP HEIGHT ADJUST	MECHANICAL
2266102-2	E	FINE CRIMP HEIGHT ADJUST	PNEUMATIC
5-2266102-1	D	SEAL STRIPPER CRIMPER TERMINATING UNIT	MECHANICAL
5-2266102-2	E	SEAL STRIPPER CRIMPER TERMINATING UNIT	PNEUMATIC
7-2266102-1	D	MECHANICAL AND CRIMP TOOLING KIT	MECHANICAL
7-2266102-2	E	PNEUMATIC AND CRIMP TOOLING KIT	PNEUMATIC
7-2266102-7	B	CRIMP TOOLING KIT	-
7-2266102-8	C	APPLICATOR CONVERSION KIT	-

ATLANTIC VERSION TERMINATOR INTERFACE ADAPTER

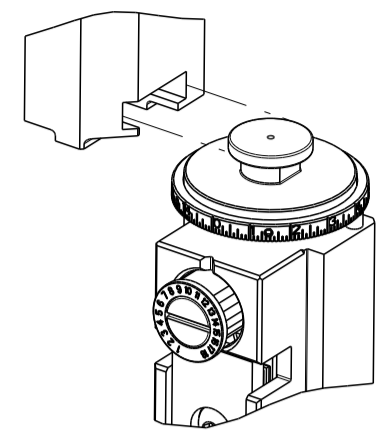

APPLICATOR DATA		
CRIMP	SIZE	TYPE
WIRE	2.29 mm [.090]	F
INSUL	2.29 mm [.090]	O

APPLICATOR INSTRUCTIONS
408-35042

APPLICATOR CONVERSION KITS		
PART NUMBER	INSULATION DIAMETER RANGE	
7-2266100-8	Ø 3.05-3.81mm [.120-.150]	
7-2266101-8	Ø 2.67-3.02mm [.105-.119]	
7-2266102-8	Ø 2.26-2.64mm [.089-.104]	
7-2266103-8	Ø 1.93-2.24mm [.076-.088]	
7-2266104-8	Ø 1.60-1.91mm [.063-.075]	

TERMINAL DATA: DEUTSCH TERMINAL TE CRIMP SPECIFICATION			
TERMINAL NAME: STAMPED CONTACT PIN SIZE 16			
WIRE STRIP LENGTH	INSULATION DIAMETER RANGE		
3.81-5.09 mm [.150-.200 IN]	Ø 2.26-2.64 mm [.089-.104 IN]		
TERMINAL APPLICATION SPECIFICATION	114-151000		
TERMINALS APPLIED			
TE TERMINAL	DEUTSCH TERMINAL	TE TERMINAL	DEUTSCH TERMINAL
286503-1	1060-16-0122	286503-2	1060-16-0144
286503-3	1060-16-0177	286503-7	1060-16-0722
286503-8	1060-16-0744	286503-9	1060-16-0777
1-286503-1	1060-16-0977	1-286503-2	1060-16-0988
1-286503-4	AT60-16-0122	1-286503-5	AT60-16-0144

TERMINAL DATA: DEUTSCH TERMINAL TE CRIMP SPECIFICATION			
TERMINAL NAME: STAMPED CONTACT SOCKET SIZE 16			
WIRE STRIP LENGTH	INSULATION DIAMETER RANGE		
3.81-5.09 mm [.150-.200 IN]	Ø 2.26-2.64 mm [.089-.104 IN]		
TERMINAL APPLICATION SPECIFICATION	114-151000		
TERMINALS APPLIED			
TE TERMINAL	DEUTSCH TERMINAL	TE TERMINAL	DEUTSCH TERMINAL
286504-1	1062-16-0122	286504-2	1062-16-0144
286504-3	1062-16-0177	286504-7	1062-16-0722
286504-8	1062-16-0744	286504-9	1062-16-0777
1-286504-1	1062-16-0977	1-286504-2	1062-16-0988
1-286504-5	AT62-16-0122	1-286504-6	AT62-16-0144

TERMINAL DATA: TE TERMINAL TE CRIMP SPECIFICATION			
TERMINAL NAME: STAMPED CONTACT PIN/SOCKET SIZE 16			
WIRE STRIP LENGTH	INSULATION DIAMETER RANGE		
3.81-5.09 mm [.150-.200 IN]	Ø 2.26-2.64 mm [.089-.104 IN]		
TERMINAL APPLICATION SPECIFICATION	114-160698		
TERMINALS APPLIED			
TE TERMINAL	TE TERMINAL	TE TERMINAL	TE TERMINAL
2500060-1	2500062-1		

WIRE SIZE	CRIMP HEIGHT mm [INCH]	CRIMP HEIGHT REFERENCE SETTING
2.00mm2	1.39+/-0.04 [.055+/- .0015]	4.7
1.50mm2	1.34+/-0.04 [.053+/- .0015]	5.3
1.00mm2	1.26+/-0.04 [.050+/- .0015]	6.1
0.75mm2	1.21+/-0.04 [.048+/- .0015]	6.5

WIRE SIZE	CRIMP HEIGHT mm [INCH]	CRIMP HEIGHT REFERENCE SETTING
14 AWG	1.40+0.03/-0.05 [.055+.001/- .002]	4.6
2.00mm2	1.40+0.03/-0.05 [.055+.001/- .002]	4.6
1.50mm2	1.35+0.03/-0.05 [.053+.001/- .002]	5.2
16 AWG	1.27+0.03/-0.05 [.050+.001/- .002]	6.0
1.00mm2	1.27+0.03/-0.05 [.050+.001/- .002]	6.0
18 AWG	1.24+0.03/-0.05 [.049+.001/- .002]	6.2
0.75mm2	1.22+0.03/-0.05 [.048+.001/- .002]	6.4

- 1. RECOMMENDED SPARE PARTS
- 2. REFER TO SUPPLIED INSTRUCTION SHEET FOR CLEANING, LUBRICATION & STORAGE OF APPLICATOR.
- 3. APPLY PART NUMBER 1-23419-5 LOCTITE TO THREADS OF ITEM 180. APPLY PART NUMBER 2-23419-6 LOCTITE TO THREADS OF ITEM 242.
- 4. CRIMP HEIGHT REFERENCE SETTING WAS THE SETTING USED WHEN THE APPLICATOR WAS QUALIFIED AT THE FACTORY. ADJUSTMENT MAY BE NECESSARY WHEN RUNNING APPLICATOR IN THE FIELD.
- 5. SEE APPROPRIATE APPLICATOR LOG SHEETS FOR APPLIED TERMINALS, WIRE RANGE AND MEMORY CHIP.
- 6. TERMINAL LUBRICANT IS RECOMMENDED.
- 7. UNLESS SPECIFIED OTHERWISE TORQUE VALUES SHALL BE USED PER DOCUMENT, 101-35000.

***WARNING**
ON INSTALLATION, SET WIRE DISC TO CRIMP HEIGHT REFERENCE SETTING FOR LARGEST WIRE SIZE. CRIMP HEIGHT REFERENCE SETTINGS GREATER THAN THE VALUE SHOWN MAY CAUSE DAMAGE TO THE CRIMP TOOLING, REFER TO THE INSTRUCTION SHEET FOR PROPER SETUP AND ADJUSTMENTS.

LOC	DIST	REVISIONS					
A	66	P	LTN	DESCRIPTION	DATE	OWN	APVD
		C		ECR-17-010304	14JUL2017	RK	GB
		D		ECR-18-010218	06JUL2018	LG	CT
		E		ECR-21-115425	28SEP2021	FJ	RK
		E1		ECR-23-192821	16NOV2023	TB	RK

-	-	-	-	1	1	-	-	1803515-3	RAM ASSEMBLY, SF ATLANTIC	293
-	-	-	-	1	1	-	-	2-1803583-1	APPLICATOR BASIC ASSEMBLY, SF	292
-	-	1	-	1	-	1	-	2119641-1	FEED CAM, AIR FEED	248
-	-	1	1	1	1	1	1	2119082-9	CAM, SWAIL, INSULATION ADJUSTMENT	244
-	-	1	1	1	1	1	1	2079764-1	WASHER, WAVE SPRING, CREST-TO-CREST	243
-	-	1	1	1	1	1	1	2119083-1	RETAINER, INSULATION DIAL	242
-	-	1	1	1	1	1	1	7-18023-7	SCR, SKT HD CAP M3 X 4.0	241
-	-	-	1	-	1	-	1	2119580-1	MECHANICAL FEED ASSEMBLY	239
-	-	-	1	-	1	-	-	2844940-1	AIR FEED MODULE	238
-	-	-	-	-	1	1	-	4-1722335-3	STRIPPER, SIDE FEED	182
-	-	-	-	-	1	1	-	1-5018030-0	NUT, HEX, REG, RoHS, M3.5	181
-	-	-	-	-	1	1	-	1-1752354-6	STANDOFF, HOLD-DOWN	180
-	-	-	-	-	1	1	-	9931111-1	PIN, SLOTTED SPRING 3.0 X 20.0	177
-	-	-	-	-	1	1	-	5-22280-0	SPRING, COMPRESSION	176
-	-	-	-	-	1	1	-	1752353-3	GUIDE PIN, HOLDDOWN	175
-	-	-	-	-	1	1	-	1901680-2	GUIDE PIN, HOLDDOWN	174
-	-	REF	REF	REF	REF	REF	REF	994970-2	COUNTER, MAGNETIC	164
-	-	1	1	1	1	1	1	1-18028-2	WASHER, FLAT, REG M4	119
-	-	1	1	1	1	1	1	2119955-1	ASSY, LUBRICATOR, SIDE FEED	113
-	-	1	1	1	1	1	1	2844908-1	SCREW, LOCKING	99
-	-	1	1	1	1	1	1	2844907-1	POST, LOCKING	98
1	-	1	1	1	1	1	1	455888-6	SPACER, CRIMPER -	82
1	-	-	-	-	-	-	-	2266102	PRINT, APPLICATOR LOG SHEET	72
-	-	1	1	1	1	1	1	1803607-3	DOCUMENTATION PACKAGE	71
-	-	2	2	2	2	2	2	2119791-9	DEPRESSOR, WIRE	70
-	-	1	1	1	1	1	1	2119740-1	TAG, IDENTIFICATION	67
-	-	2	2	2	2	2	2	2168078-1	SCREW, DRIVE, RH, RoHS, 2 x .188	66
-	-	1	1	1	1	1	1	2168083-2	SCR, SKT HD CAP, RoHS, M4 X 8.0	60
-	-	1	1	1	1	1	1	5-18022-5	SCR, HEX HD CAP, M4 X 6.0	59
-	-	1	1	1	1	1	1	1338685-1	PAWL, FEED	56
-	-	4	4	4	4	4	4	2168083-3	SCR, SKT HD CAP, RoHS, M4 X 12.0	54
-	-	2	2	2	2	2	2	1-2168083-0	SCR, SKT HD CAP, RoHS, M4 X 10	53
-	-	1	1	1	1	1	1	5018030-1	NUT, HEX, REG, RoHS, M3	52
-	-	1	1	1	1	1	1	811242-5	BUMPER, HOLD DOWN	51
-	-	1	1	1	1	1	1	690753-2	SPACER, TONKER	50
-	-	1	2	1	2	1	2	18023-9	SCR, SKT HD CAP M4 X 6.0	49
-	-	-	1	-	1	-	1	2119652-1	FEED CAM, PRE FEED	48
-	-	-	1	-	1	-	1	2119653-1	FEED CAM, POST FEED	47
-	-	1	1	-	-	1	1	1803583-9	APPLICATOR BASIC ASSEMBLY, SF	46
-	-	1	1	-	-	1	1	1803515-1	RAM ASSEMBLY, SF ATLANTIC	44
-	-	1	1	1	1	1	1	1803602-1	SCR, BHSC, RoHS (M8 X 25)	41
-	-	1	1	1	1	1	1	2-1752356-0	SUPPORT, TERMINAL	34
-	-	2	2	2	2	2	2	2079383-5	SCR, BHSC, RoHS (M4 X 20)	33
-	-	2	2	2	2	2	2	2-2844962-8	SPACER, CYLINDRICAL, STRIP GUIDE	30
-	-	1	1	1	1	1	1	2844992-1	ASSEMBLY, STRIP GUIDE -	29
-	-	1	1	1	1	1	1	1320928-2	STRIP GUIDE	24
-	-	1	1	-	-	1	1	2168083-2	SCR, SKT HD CAP, RoHS, M4 X 8.0	21
-	-	1	1	-	-	1	1	1-18028-2	WASHER, FLAT, REG M4	20
-	-	1	1	-	-	1	1	2119533-1	STRIPPER, SIDE FEED	19
-	-	1	1	1	1	1	1	2119806-1	INSERT, SHEAR	13
-	-	1	1	1	1	1	1	3-22280-3	SPRING, COMPRESSION	12
-	-	1	1	1	1	1	1	1-356885-4	STOP, SHEAR	11
-	-	1	1	1	1	1	1	2119805-1	SHEAR HOLDER, FRONT -	10
-	-	1	1	1	1	1	1	1803095-1	FLOATING SHEAR, FRONT -	9
1	1	2	2	1	1	1	1	1803293-3	ANVIL, COMBINATION DEUTSCH STYLE	8
-	-	-	-	-	-	-	-	-	-	7
-	-	-	-	-	-	-	-	-	-	6
-	-	1	1	1	1	1	1	2119757-8	DEPRESSOR, SHEAR	5
-	-	1	1	1	1	1	1	238011-9	BLOCK, CRIMPER SPACER	4
1	1	2	2	1	1	1	1	1803019-5	CRIMPER, INSULATION O	3
1	-	1	1	1	1	1	1	455888-4	SPACER, CRIMPER -	2
-	-	1	2	2	1	1	1	2-1633713-6	CRIMPER, WIRE PREMIUM	1

ITEM NO	PART NO	DESCRIPTION	ITEM NO
-78	-77	-72	-71
-52	-51	-2	-1
DIMENSIONS:		TOLERANCES UNLESS OTHERWISE SPECIFIED:	
mm	0 PLC ±	1 PLC ±	2 PLC ±
	3 PLC ±	4 PLC ±	ANGLES ±
MATERIAL	FINISH	WEIGHT	SCALE
Customer Accessible Production Drawing		SCALE	SHEET 1 OF 4

LOC	DIST	REVISIONS					
A	66	P	LYN	DESCRIPTION	DATE	DWN	APVD
		-		SEE SHEET 1			

FEED TYPE MECHANICAL

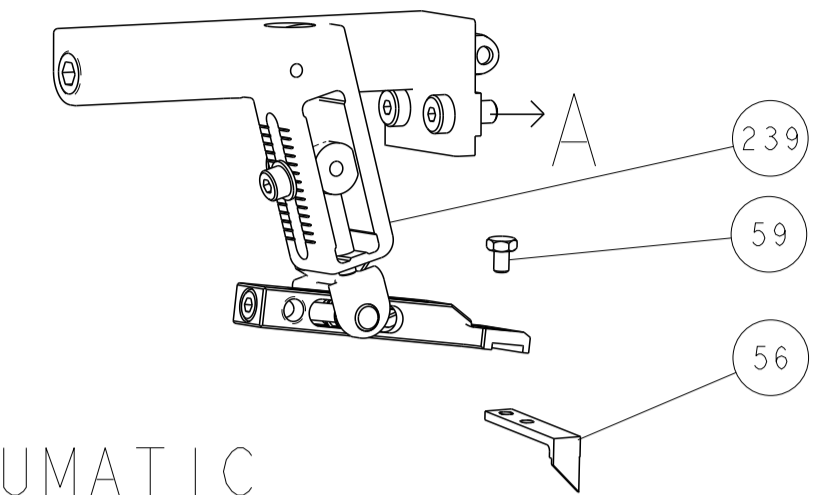

PNEUMATIC

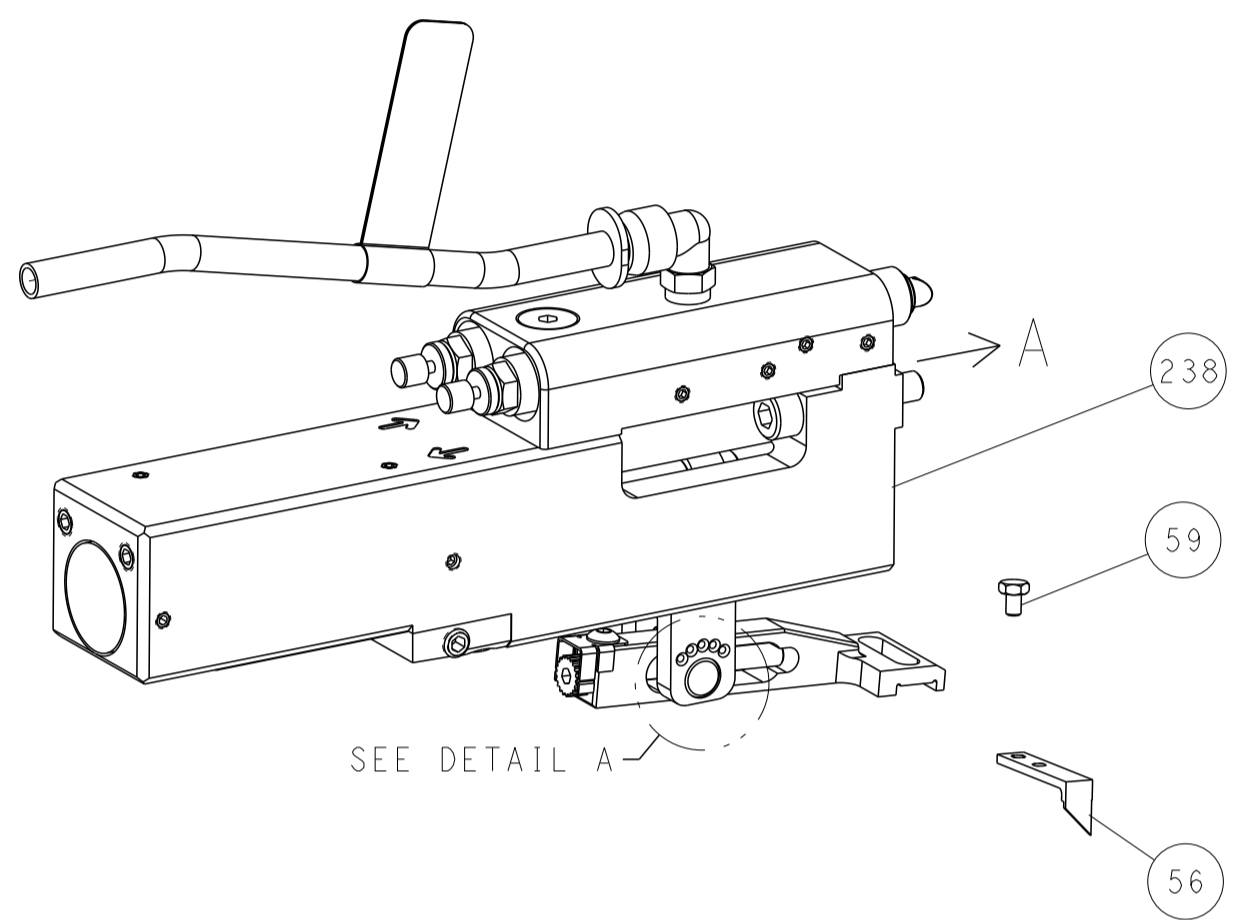

FEED SPRING SETTING POSITION (SHOWN FROM REAR SIDE)



CAM POSITIONS

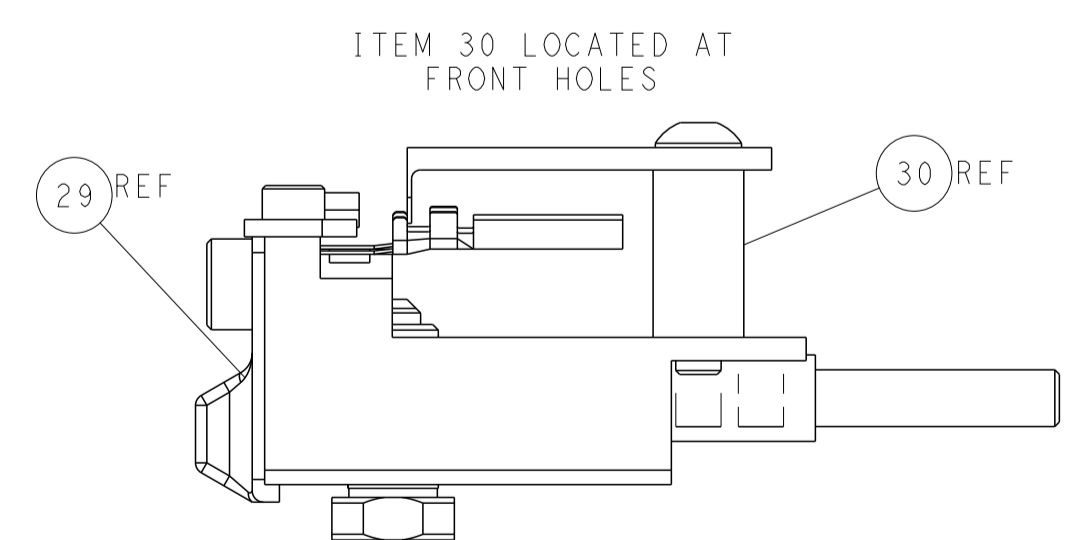
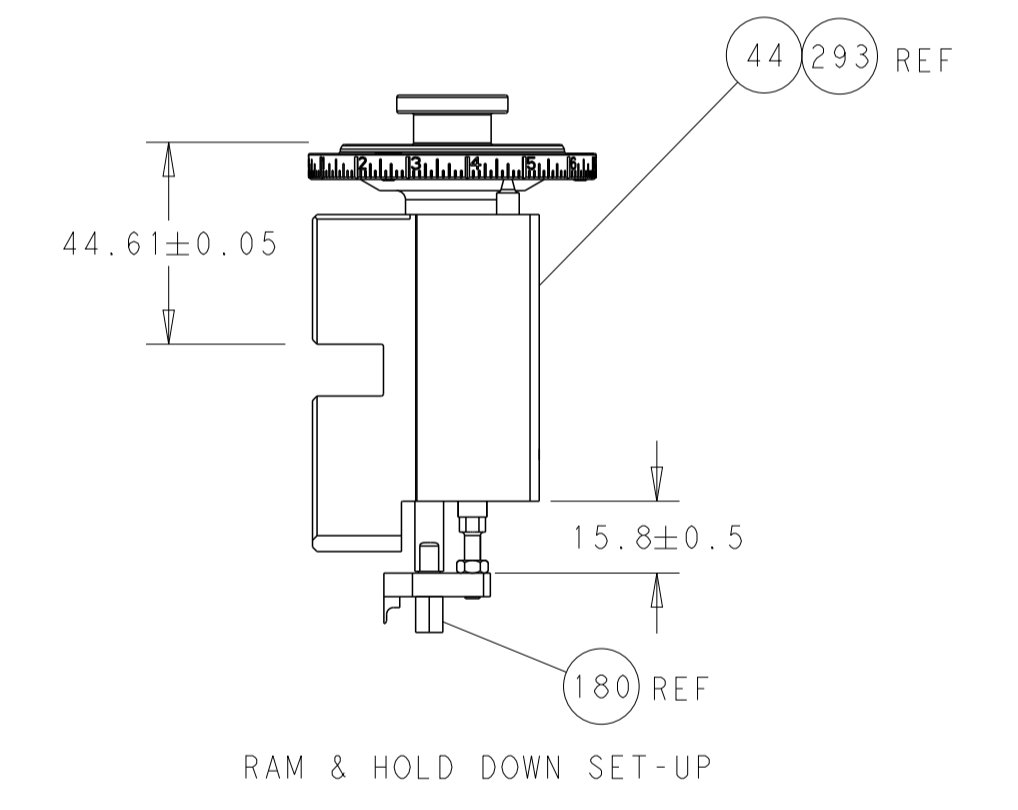
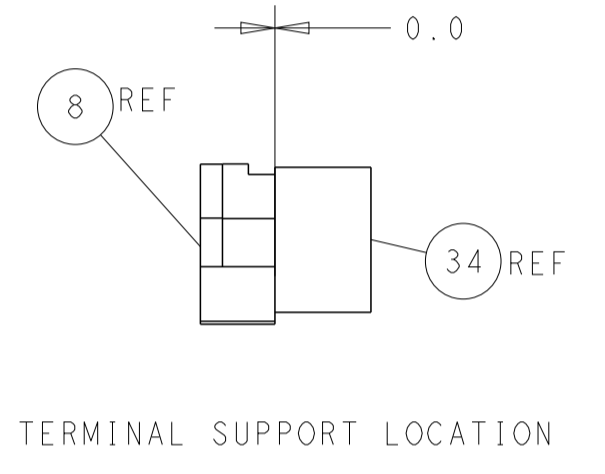
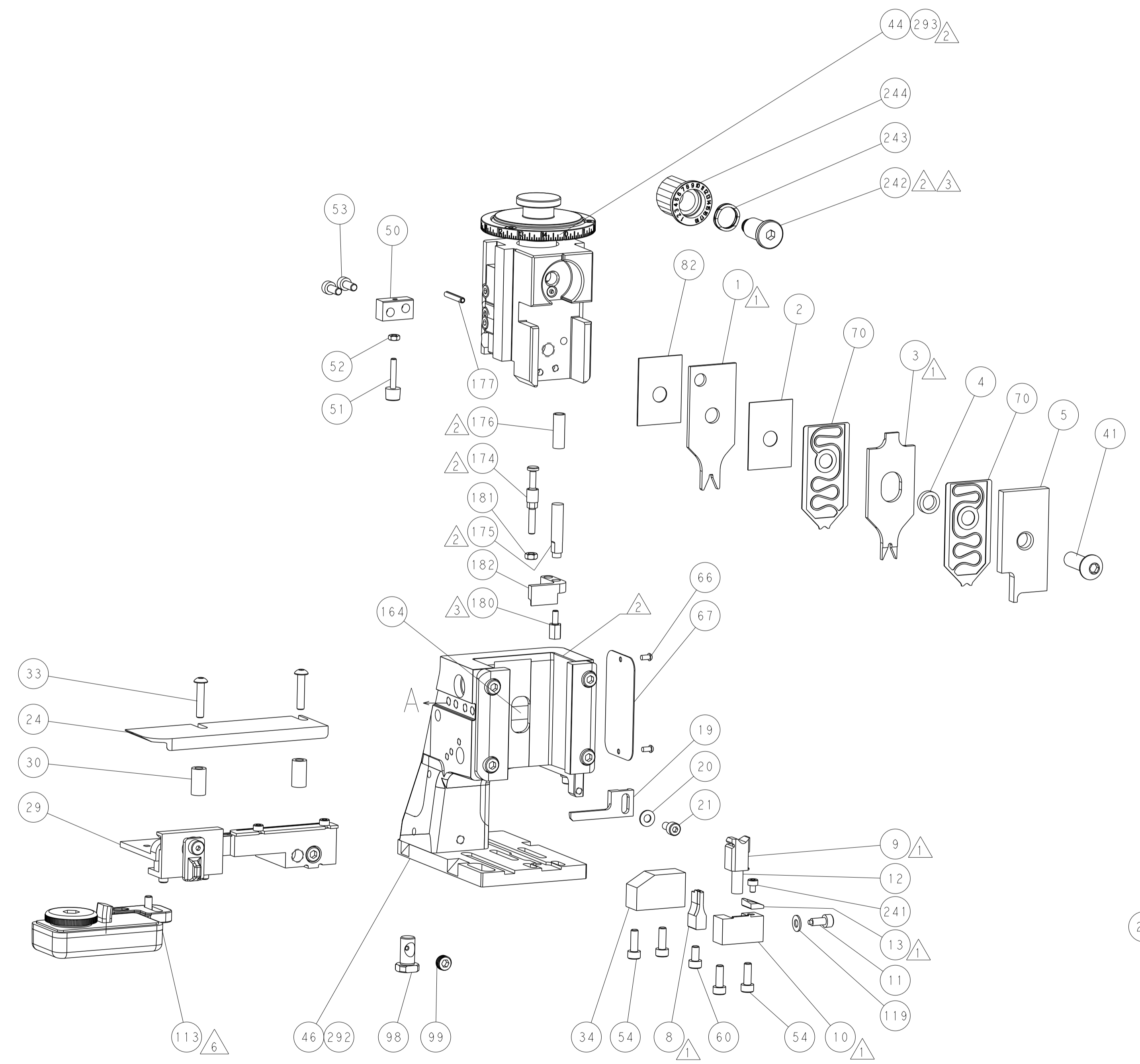
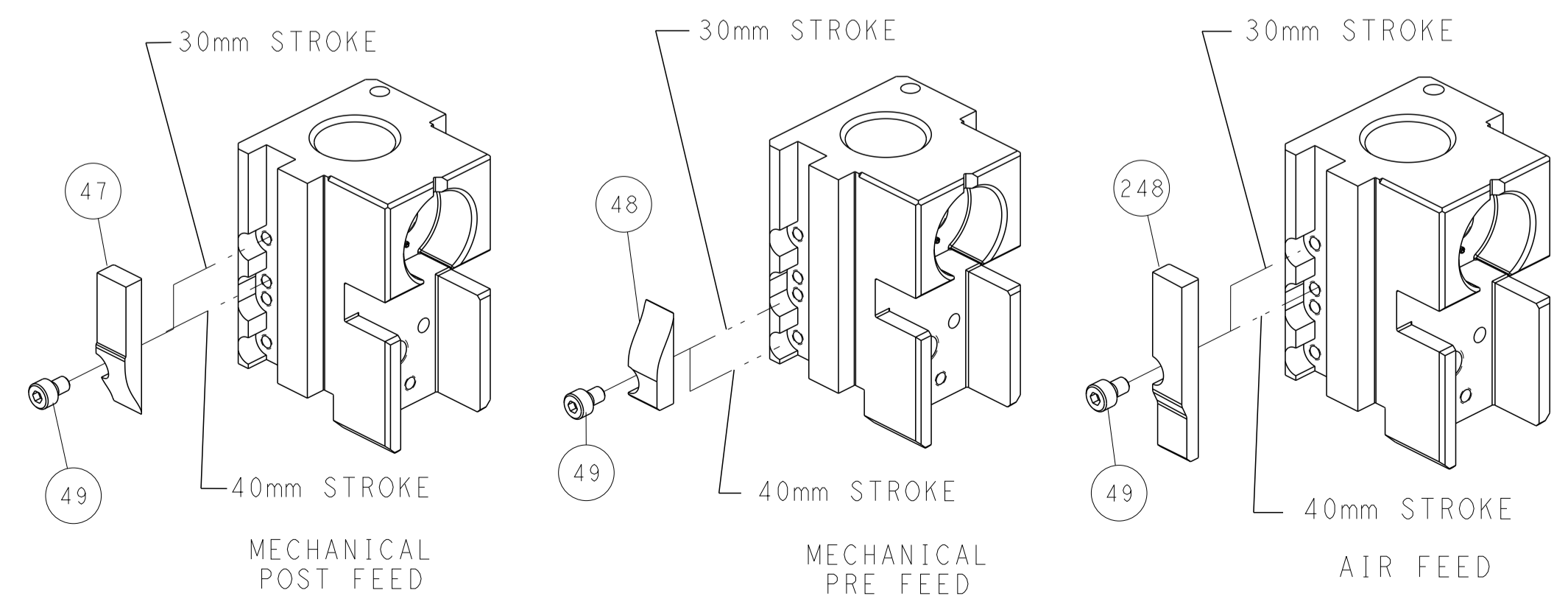

DIMENSIONS: mm 		TOLERANCES UNLESS OTHERWISE SPECIFIED: 0 PLC ± 1 PLC ± 2 PLC ± 3 PLC ± 4 PLC ± ANGLES ± FINISH		DWN R. KNEPPER 04-Oct-13 CHK G. BAILEY 04-Oct-13 APVD M. CLIFFORD 04-Oct-13 PRODUCT SPEC APPLICATION SPEC WEIGHT SCALE 1:2		NAME Ocean Side Feed Applicator SIZE CAGE CODE DRAWING NO. RESTRICTED TO A1 00779 C=2266102 SHEET 2 OF 4 REV E1	
MATERIAL				Customer Accessible Production Drawing		SHEETS 3 & 4 ARE NOT REQUIRED FOR ATLANTIC VERSION	