

PART NUMBER	REVISION	DESCRIPTION	FEED TYPE
2266087-1	C	FINE CRIMP HEIGHT ADJUST	MECHANICAL
2266087-2	C	FINE CRIMP HEIGHT ADJUST	PNEUMATIC
7-2266087-1	C	MECHANICAL AND CRIMP TOOLING KIT	MECHANICAL
7-2266087-2	C	PNEUMATIC AND CRIMP TOOLING KIT	PNEUMATIC
7-2266087-7	A	CRIMP TOOLING KIT	-

ATLANTIC VERSION TERMINATOR INTERFACE ADAPTER



APPLICATOR DATA		
CRIMP	SIZE	TYPE
WIRE	2.79 mm [.110]	F
INSUL	3.94 mm [.155]	OV

APPLICATOR INSTRUCTIONS
408-35042

TERMINAL DATA: G & H TERMINAL LEAR CRIMP SPECIFICATION			
TERMINAL NAME: DFK 3 - FLACHKONTAKT 4.8X0.8-2.5			
WIRE STRIP LENGTH 5.50-5.50 mm [.217-.217 IN]		INSULATION DIAMETER RANGE Ø2.15-2.70 mm [.085-.106 IN]	
TERMINAL APPLICATION SPECIFICATION 26317 Rev 6			
TERMINALS APPLIED			
TE TERMINAL	G & H TERMINAL	TE TERMINAL	G & H TERMINAL
2113395-1	26317.201.179	2113395-6	26317.201.123
2113395-2	26317.331.179	2113395-7	26317.201.418
2113395-3	26317.331.142	2113395-8	26317.201.178
2113395-4	26317.306.179	2113395-9	26317.163.410
2113395-5	26317.306.142	1-2113395-0	26231.XXX.XXX

WIRE SIZE	CRIMP HEIGHT mm [INCH]	CRIMP HEIGHT REFERENCE SETTING
2.50mm2	1.85+/-0.05 [.073+/-0.002]	3.7
1.50+0.75mm2	1.80+/-0.05 [.071+/-0.002]	4.1
2x1.00mm2	1.75+/-0.05 [.069+/-0.002]	4.6
1.00+0.75mm2	1.65+/-0.05 [.065+/-0.002]	5.8
1.50mm2	1.55+/-0.05 [.061+/-0.002]	6.8

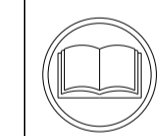

- 1 RECOMMENDED SPARE PARTS
- 2 REFER TO SUPPLIED INSTRUCTION SHEET FOR CLEANING, LUBRICATION AND STORAGE OF APPLICATOR.
- 3 APPLY PART NUMBER 2-23419-6 LOCTITE TO THREADS OF ITEM 242.
- 4 CRIMP HEIGHT REFERENCE SETTING WAS THE SETTING USED WHEN THE APPLICATOR WAS QUALIFIED AT THE FACTORY. ADJUSTMENT MAY BE NECESSARY WHEN RUNNING APPLICATOR IN THE FIELD.
- 5. UNLESS SPECIFIED OTHERWISE TORQUE VALUES SHALL BE USED PER DOCUMENT, 101-35000.

***WARNING**
ON INSTALLATION, SET WIRE DISC TO CRIMP HEIGHT REFERENCE SETTING FOR LARGEST WIRE SIZE. CRIMP HEIGHT REFERENCE SETTINGS GREATER THAN THE VALUE SHOWN MAY CAUSE DAMAGE TO THE CRIMP TOOLING, REFER TO THE INSTRUCTION SHEET FOR PROPER SETUP AND ADJUSTMENTS.

LOC	DIST	REVISIONS			
P	LTN	DESCRIPTION	DATE	OWN	APVD
A	66	RELEASED	11DEC2013	KH	UG
B		ECR-20-002227	17FEB2020	FJ	TE
C		ECR-20-004070	18MAR2020	TB	GB

-	1	-	1	-	2119641-1	FEED CAM, AIR FEED	248
-	1	1	1	1	2119082-8	CAM, SNAIL, INSULATION ADJUSTMENT	244
-	1	1	1	1	2079764-1	WASHER, WAVE SPRING, CREST-TO-CREST	243
-	1	1	1	1	2119083-1	RETAINER, INSULATION DIAL	242
-	1	1	1	1	7-18023-7	SCR, SKT HD CAP M3 X 4.0	241
-	-	1	-	1	2119580-1	MECHANICAL FEED ASSEMBLY	239
-	1	-	1	-	2844940-1	AIR FEED MODULE	238
-	REF	REF	REF	REF	994970-2	COUNTER, MAGNETIC	164
-	1	1	1	1	2844908-1	SCREW, LOCKING	99
-	1	1	1	1	2844907-1	POST, LOCKING	98
-	1	1	1	1	318563-1	GUARD, FRONT CHIP	89
-	1	1	1	1	455888-5	SPACER, CRIMPER	82
-	1	1	1	1	1803607-3	DOCUMENTATION PACKAGE	71
-	1	1	1	1	2119791-5	DEPRESSOR, WIRE	70
-	1	1	1	1	2119943-1	WASHER, SPACER	69
-	1	1	1	1	2119740-1	TAG, IDENTIFICATION	67
-	2	2	2	2	2168078-1	SCREW, DRIVE, RH, RoHS, 2 x .188	66
-	1	1	1	1	2168083-2	SCR, SKT HD CAP, RoHS, M4 X 8.0	60
-	1	1	1	1	5-18022-5	SCR, HEX HD CAP, M4 X 6.0	59
-	1	1	1	1	1338683-8	FEED PAWL	56
-	4	4	4	4	2168083-3	SCR, SKT HD CAP, RoHS, M4 X 12.0	54
-	2	2	2	2	2168083-8	SCR, SKT HD CAP, RoHS, M4 X 16	53
-	1	1	1	1	1803382-6	HOLD DOWN, SPRING LOADED	50
-	1	2	1	2	18023-9	SCR, SKT HD CAP M4 X 6.0	49
-	-	1	-	1	2119652-1	FEED CAM, PRE FEED	48
-	-	1	-	1	2119653-1	FEED CAM, POST FEED	47
-	1	1	1	1	1803583-9	APPLICATOR BASIC ASSEMBLY, SF	46
-	1	1	1	1	1803515-1	RAM ASSEMBLY, SF ATLANTIC	44
-	1	1	1	1	1803602-1	SCR, BHSC, RoHS (M8 X 25)	41
-	1	1	1	1	3-1752356-3	SUPPORT, TERMINAL	34
-	2	2	2	2	2079383-5	SCR, BHSC, RoHS (M4 X 20)	33
-	2	2	2	2	3-2844962-0	SPACER, CYLINDRICAL, STRIP GUIDE	30
-	1	1	1	1	1-2844992-1	ASSEMBLY, STRIP GUIDE	29
-	1	1	1	1	1-455888-0	SPACER, CRIMPER	28
-	1	1	1	1	1320928-2	STRIP GUIDE	24
-	1	1	1	1	2168083-2	SCR, SKT HD CAP, RoHS, M4 X 8.0	21
-	1	1	1	1	1-18028-2	WASHER, FLAT, REG M4	20
-	1	1	1	1	2119533-1	STRIPPER, SIDE FEED	19
-	1	1	1	1	2119806-1	INSERT, SHEAR	13
-	1	1	1	1	3-22280-3	SPRING, COMPRESSION	12
-	1	1	1	1	1-356885-4	STOP, SHEAR	11
-	1	1	1	1	2119805-1	SHEAR HOLDER, FRONT	10
-	1	1	1	1	318707-1	FLOATING SHEAR, FRONT	9
-	1	2	2	1	1633923-7	ANVIL, COMBINATION	8
-	1	1	1	1	1-240641-9	SPACER	7
-	-	-	-	-	-	-	6
-	1	1	1	1	1-2119757-0	DEPRESSOR, SHEAR	5
-	1	1	1	1	238011-4	BLOCK, CRIMPER SPACER	4
-	1	2	2	1	2-2119785-9	CRIMPER, INSULATION OVERLAP PREMIUM	3
-	-	-	-	-	-	-	2
-	1	2	2	1	7-456408-0	CRIMPER, WIRE PREMIUM	1
-	77	-72	-71	-2	-1	PART NO	ITEM NO

ATLANTIC VERSION
Shown on sheets 1 of 4 & 2 of 4
(Pacific version shown on sheets 3 of 4 & 4 of 4)

DIMENSIONS: mm		TOLERANCES UNLESS OTHERWISE SPECIFIED:		DWG: H. HUANG 25OCT2013		CHK: L. ZHANG 25OCT2013		NAME: Ocean Side Feed Applicator	
0 PLC ±.5		1 PLC ±0.5		APVD: J. GUO 25OCT2013		PRODUCT SPEC: -		SIZE: A1	
2 PLC ±0.13		3 PLC ±0.013		APPLICATION SPEC: -		WEIGHT: -		SCALE: 1:2	
4 PLC ±0.001		ANGLES ±.001		MATERIAL: -		FINISH: -		SHEET 1 OF 4	
CUSTOMER ACCESSIBLE PRODUCTION DRAWING		SCALE: 1:2		SHEET 1 OF 4		REV C		DATE: 00779 ©=2266087	

LOC	DIST	REVISIONS					
A	66	P	LTN	DESCRIPTION	DATE	DWN	APVD
		-		SEE SHEET 1	-	-	-

FEED TYPE MECHANICAL

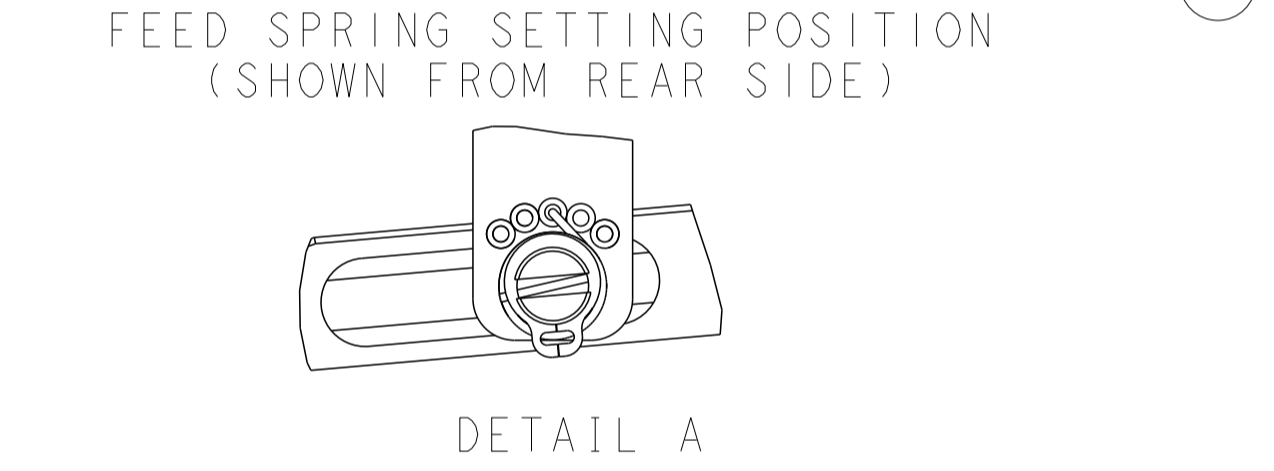
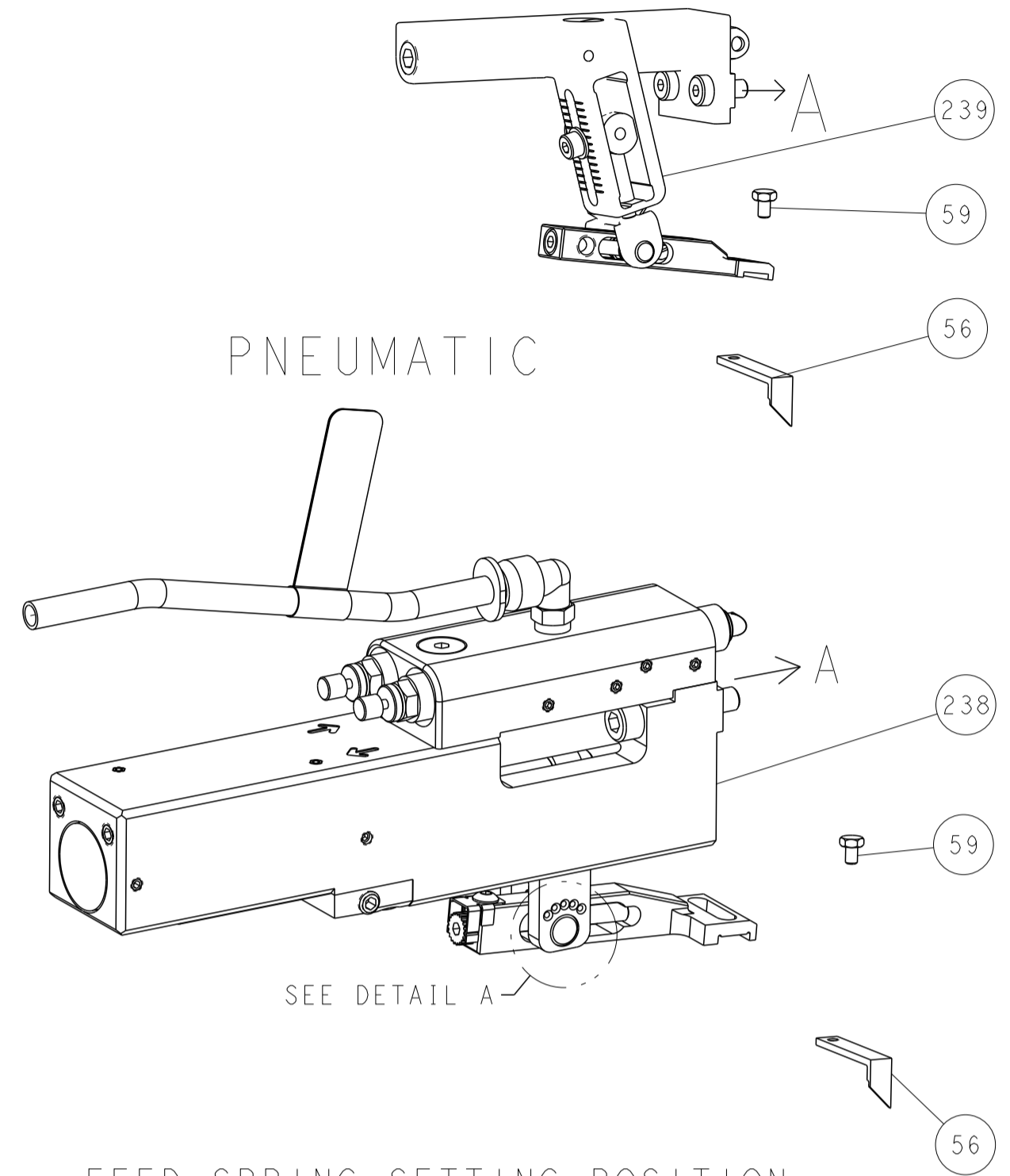

CAM POSITIONS

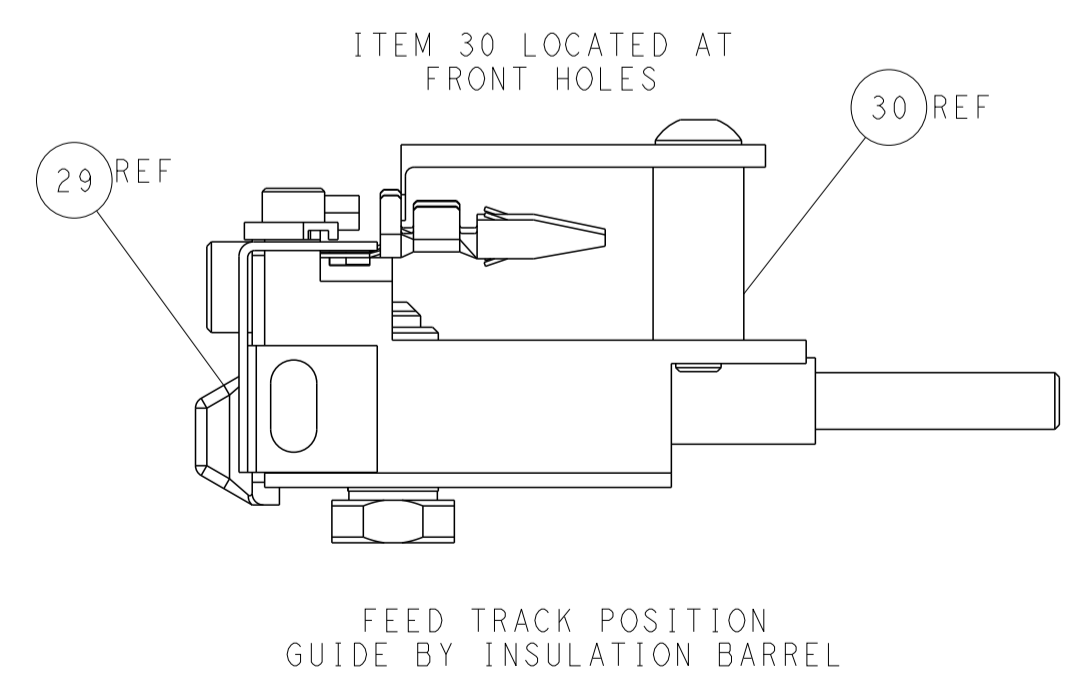
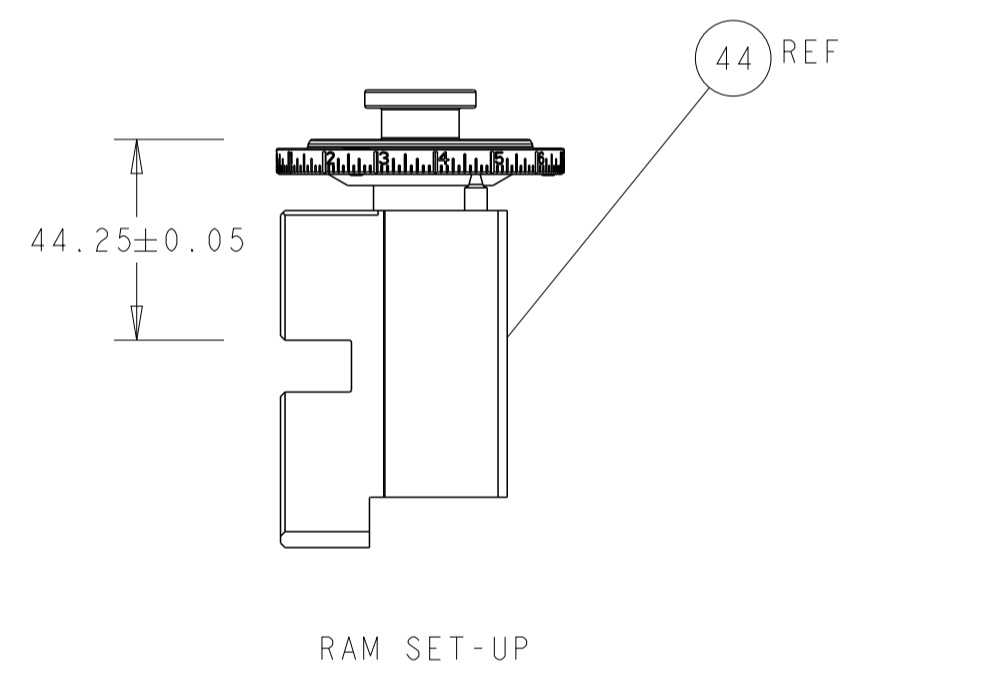
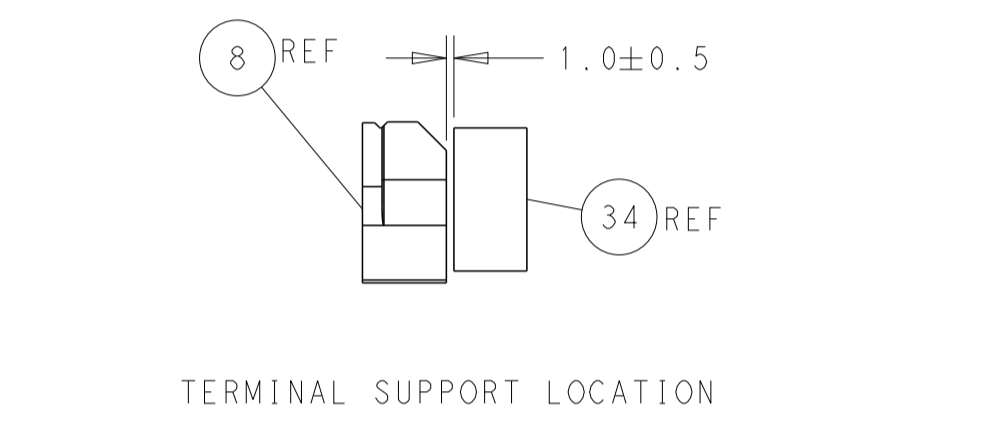
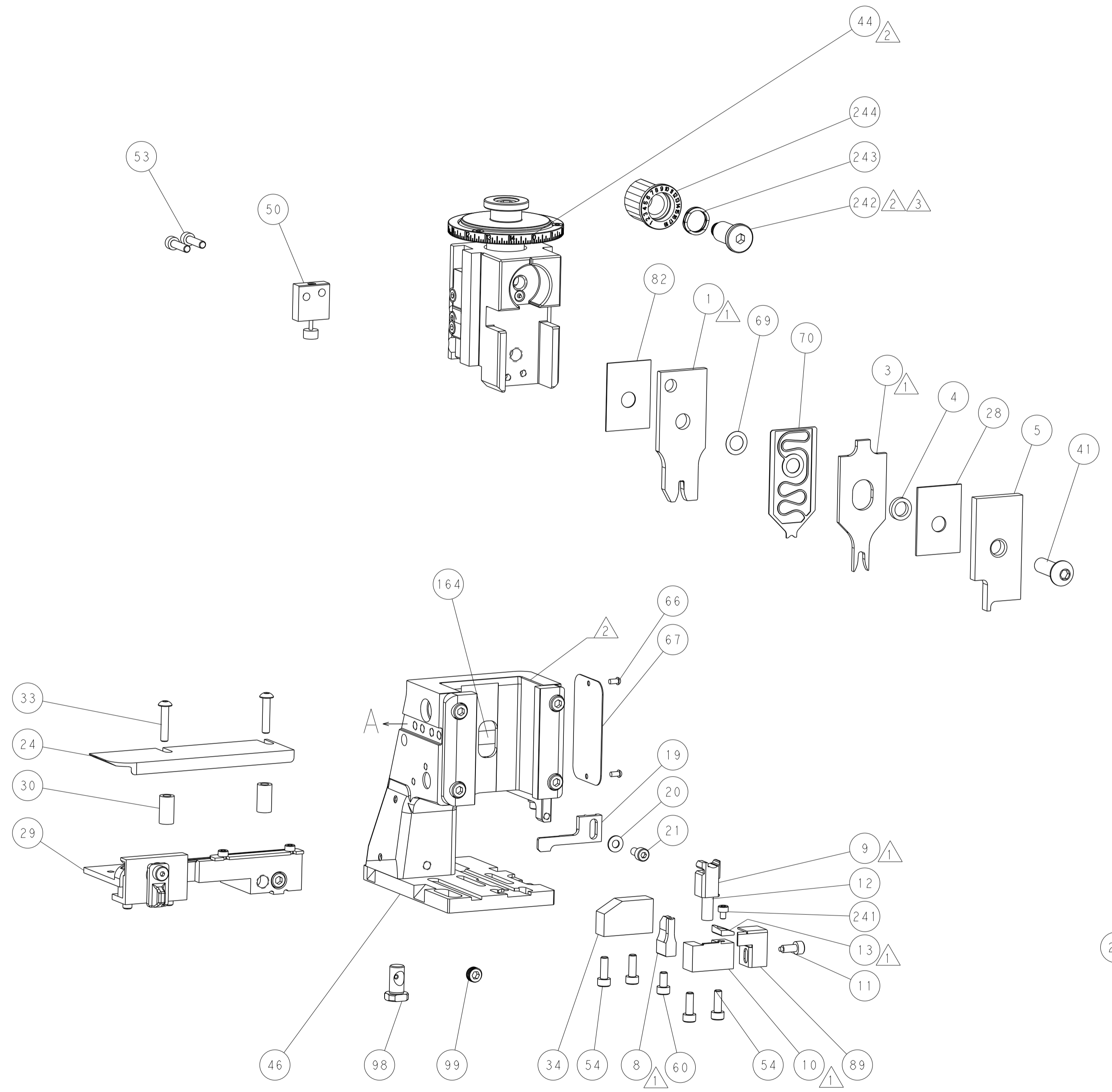
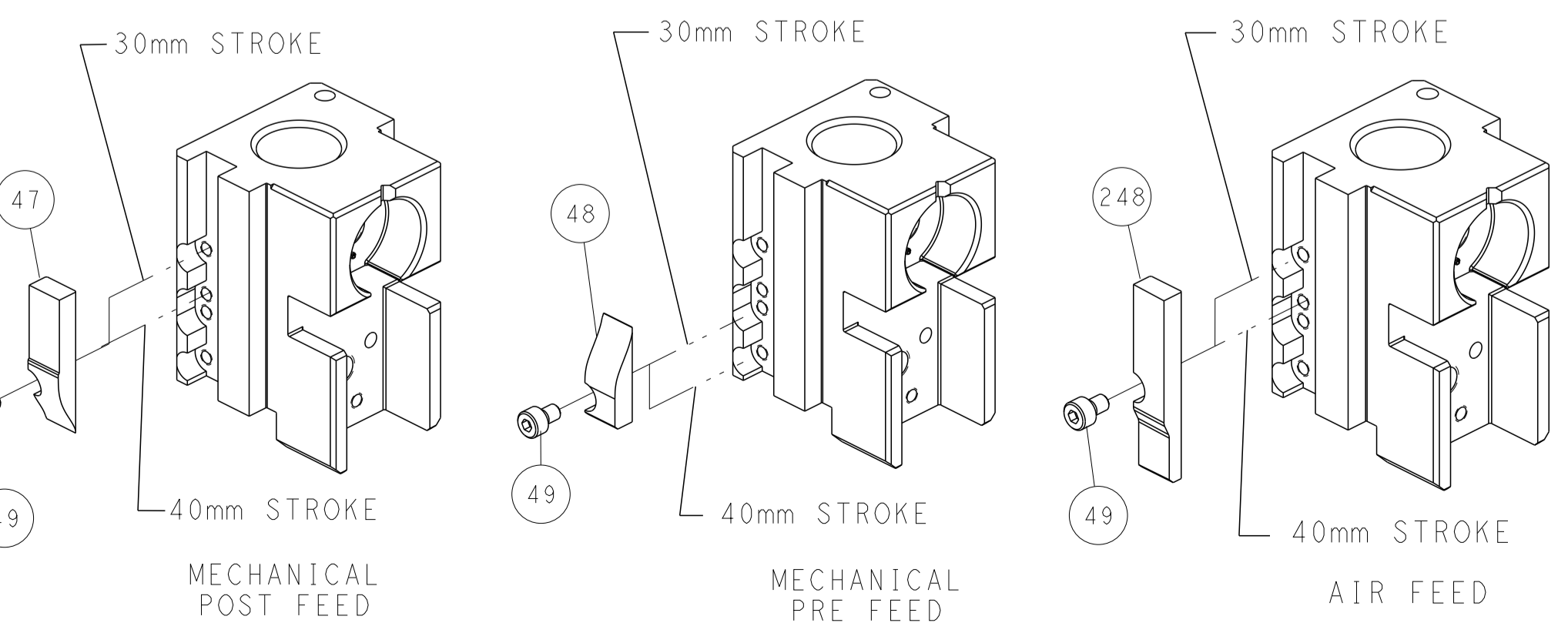

ATLANTIC VERSION
 Shown on sheets 1 of 4 & 2 of 4
 (Pacific version shown on sheets 3 of 4 & 4 of 4)

DIMENSIONS:		TOLERANCES UNLESS OTHERWISE SPECIFIED:		DWN: H. HUANG 25OCT2013		TE Connectivity	
mm		0 PLC ±0.5		CHK: L. ZHANG 25OCT2013		Harrisburg, PA 17105-3608	
Ø		1 PLC ±0.5		APVD: J. GUO 25OCT2013		NAME: Ocean Side Feed Applicator	
H		2 PLC ±0.13		PRODUCT SPEC		SIZE: CAGE CODE: DRAWING NO: RESTRICTED TO	
D		3 PLC ±0.013		APPLICATION SPEC		A1 00779 C=2266087	
R		4 PLC ±0.001		WEIGHT		SCALE: 1:2 SHEET 2 OF 4 REV C	
ANGLES		FINISH		Customer Accessible Production Drawing			

PART NUMBER	REVISION	DESCRIPTION	FEED TYPE
2-2266087-1	C	FINE CRIMP HEIGHT ADJUST	MECHANICAL
2-2266087-2	C	FINE CRIMP HEIGHT ADJUST	PNEUMATIC
7-2266087-7	A	CRIMP TOOLING KIT	-

PACIFIC VERSION TERMINATOR
INTERFACE ADAPTER



APPLICATOR DATA		
CRIMP	SIZE	TYPE
WIRE	2.79 mm [.110]	F
INSUL	3.94 mm [.155]	OV
APPLICATOR INSTRUCTIONS 408-35042		

TERMINAL DATA: G & H TERMINAL		LEAR CRIMP SPECIFICATION	
TERMINAL NAME: DFK 3 - FLACHKONTAKT 4.8X0.8-2.5			
WIRE STRIP LENGTH 5.50-5.50 mm [.217-.217 IN]		INSULATION DIAMETER RANGE Ø2.15-2.70 mm [.085-.106 IN]	
TERMINAL APPLICATION SPECIFICATION	26317 Rev 6	-	-

TERMINALS APPLIED			
TE TERMINAL	G & H TERMINAL	TE TERMINAL	G & H TERMINAL
2113395-1	26317.201.179	2113395-6	26317.201.123
2113395-2	26317.331.179	2113395-7	26317.201.418
2113395-3	26317.331.142	2113395-8	26317.201.178
2113395-4	26317.306.179	2113395-9	26317.163.410
2113395-5	26317.306.142	1-2113395-0	26231.XXX.XXX

WIRE SIZE	CRIMP HEIGHT mm [INCH]	CRIMP HEIGHT REFERENCE SETTING
2.50mm ²	1.85+/-0.05 [.073+/- .002]	3.7
1.50+0.75mm ²	1.80+/-0.05 [.071+/- .002]	4.1
2x1.00mm ²	1.75+/-0.05 [.069+/- .002]	4.6
1.00+0.75mm ²	1.65+/-0.05 [.065+/- .002]	5.8
1.50mm ²	1.55+/-0.05 [.061+/- .002]	6.8

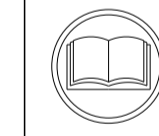

- 1 RECOMMENDED SPARE PARTS
- 2 REFER TO SUPPLIED INSTRUCTION SHEET FOR CLEANING, LUBRICATION AND STORAGE OF APPLICATOR.
- 3 APPLY PART NUMBER 2-23419-6 LOCTITE TO THREADS OF ITEM 242.
- 4 CRIMP HEIGHT REFERENCE SETTING WAS THE SETTING USED WHEN THE APPLICATOR WAS QUALIFIED AT THE FACTORY. ADJUSTMENT MAY BE NECESSARY WHEN RUNNING APPLICATOR IN THE FIELD.
- 5. UNLESS SPECIFIED OTHERWISE TORQUE VALUES SHALL BE USED PER DOCUMENT, 101-35000.

***WARNING**
ON INSTALLATION, SET WIRE DISC TO CRIMP HEIGHT REFERENCE SETTING FOR LARGEST WIRE SIZE. CRIMP HEIGHT REFERENCE SETTINGS GREATER THAN THE VALUE SHOWN MAY CAUSE DAMAGE TO THE CRIMP TOOLING, REFER TO THE INSTRUCTION SHEET FOR PROPER SETUP AND ADJUSTMENTS.

PACIFIC VERSION
Shown on sheets 3 of 4 & 4 of 4
(Atlantic version shown on sheets 1 of 4 & 2 of 4)

LOC	DIST	REVISIONS					
A	66	P	LTN	DESCRIPTION	DATE	OWN	APVD
-	-	-	-	SEE SHEET 1	-	-	-

-	1	1	2119082-8	CAM, SNAIL, INSULATION ADJUSTMENT	244
-	1	1	2079764-1	WASHER, WAVE SPRING, CREST-TO-CREST	243
3	-	1	2119083-1	RETAINER, INSULATION DIAL	242
-	1	1	7-18023-7	SCR, SKT HD CAP M3 X 4.0	241
-	-	1	2119580-1	MECHANICAL FEED ASSEMBLY	239
-	1	-	2844940-1	AIR FEED MODULE	238
-	REF	REF	994970-2	COUNTER, MAGNETIC	164
-	1	-	2119641-2	FEED CAM, AIR FEED	151
-	1	1	2168083-8	SCR, SKT HD CAP, RoHS, M4 X 16	144
-	4	4	2168083-9	SCR, SKT HD CAP, RoHS, M4 X 20	143
-	-	1	2119653-2	FEED CAM, POST FEED	142
-	1	1	1-1803583-0	APPLICATOR BASIC ASSEMBLY, SF	141
-	1	1	1803516-1	RAM ASSEMBLY, SF PACIFIC	140
-	1	1	2844908-1	SCREW, LOCKING	99
-	1	1	2844907-1	POST, LOCKING	98
-	1	1	318563-1	GUARD, FRONT CHIP	89
-	1	1	455888-5	SPACER, CRIMPER	82
-	1	1	1803607-3	DOCUMENTATION PACKAGE	71
-	1	1	2119791-5	DEPRESSOR, WIRE	70
-	1	1	2119943-1	WASHER, SPACER	69
-	1	1	2119740-1	TAG IDENTIFICATION	67
-	2	2	2168078-1	SCREW, DRIVE, RH, RoHS, 2 x .188	66
-	1	1	5-18022-5	SCR, HEX HD CAP, M4 X 6.0	59
-	1	1	1338683-8	FEED PAWL	56
-	2	2	2168083-8	SCR, SKT HD CAP, RoHS, M4 X 16	53
-	1	1	1803382-6	HOLD DOWN, SPRING LOADED	50
-	1	2	18023-9	SCR, SKT HD CAP M4 X 6.0	49
-	-	1	2119652-1	FEED CAM, PRE FEED	48
-	1	1	1803602-1	SCR, BHSC, RoHS (M8 X 25)	41
-	1	1	3-1752356-3	SUPPORT, TERMINAL	34
-	2	2	2079383-5	SCR, BHSC, RoHS (M4 X 20)	33
-	2	2	3-2844962-0	SPACER, CYLINDRICAL, STRIP GUIDE	30
-	1	1	1-2844992-1	ASSEMBLY, STRIP GUIDE	29
-	1	1	1-455888-0	SPACER, CRIMPER	28
-	1	1	1320928-2	STRIP GUIDE	24
-	1	1	2168083-2	SCR, SKT HD CAP, RoHS, M4 X 8.0	21
-	1	1	1-18028-2	WASHER, FLAT, REG M4	20
-	1	1	2119533-1	STRIPPER, SIDE FEED	19
△	-	1	2119806-1	INSERT, SHEAR	13
-	1	1	3-22280-3	SPRING, COMPRESSION	12
-	1	1	1-356885-4	STOP, SHEAR	11
△	-	1	2119805-1	SHEAR HOLDER, FRONT	10
△	-	1	318707-1	FLOATING SHEAR, FRONT	9
△	1	1	1633923-7	ANVIL, COMBINATION	8
-	1	1	1-240641-9	SPACER	7
-	-	-	-	-	6
-	1	1	1-2119757-0	DEPRESSOR, SHEAR	5
-	1	1	238011-4	BLOCK, CRIMPER SPACER	4
△	1	1	2-2119785-9	CRIMPER, INSULATION OVERLAP PREMIUM	3
-	-	-	-	-	2
△	1	1	7-456408-0	CRIMPER, WIRE PREMIUM	1

DIMENSIONS:		TOLERANCES UNLESS OTHERWISE SPECIFIED:		DWG: H. HUANG 25OCT2013		CHK: L. ZHANG 25OCT2013		APVD: J. GUO 25OCT2013		NAME: Ocean Side Feed Applicator	
mm	0 PLC ±.5	1 PLC ±0.5	2 PLC ±0.13	3 PLC ±0.013	4 PLC ±0.001	ANGLES ±.001	FINISH	SIZE: A1	CAGE CODE: 00779	DRAWING NO: C=2266087	RESTRICTED TO: -
MATERIAL: -								WEIGHT: -		SCALE: 1:2	
Customer Accessible Production Drawing								SHEET 3 OF 4		REV C	

LOC		DIST		REVISIONS			
A	66	P	LTM	DESCRIPTION	DATE	DWN	APVD
		-		SEE SHEET 1			

FEED TYPE MECHANICAL

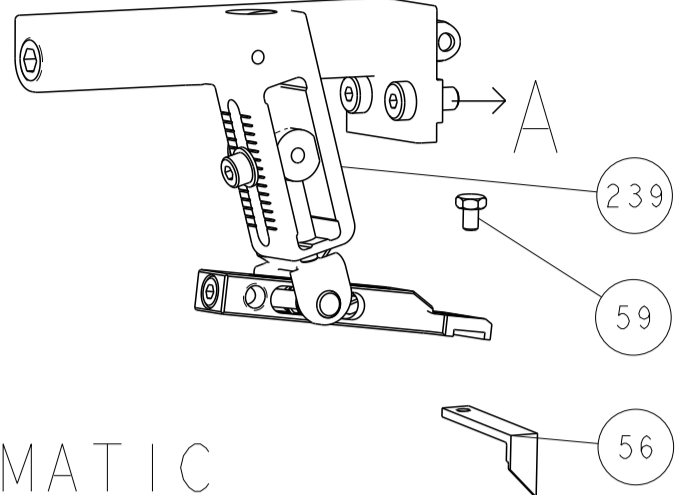

PNEUMATIC

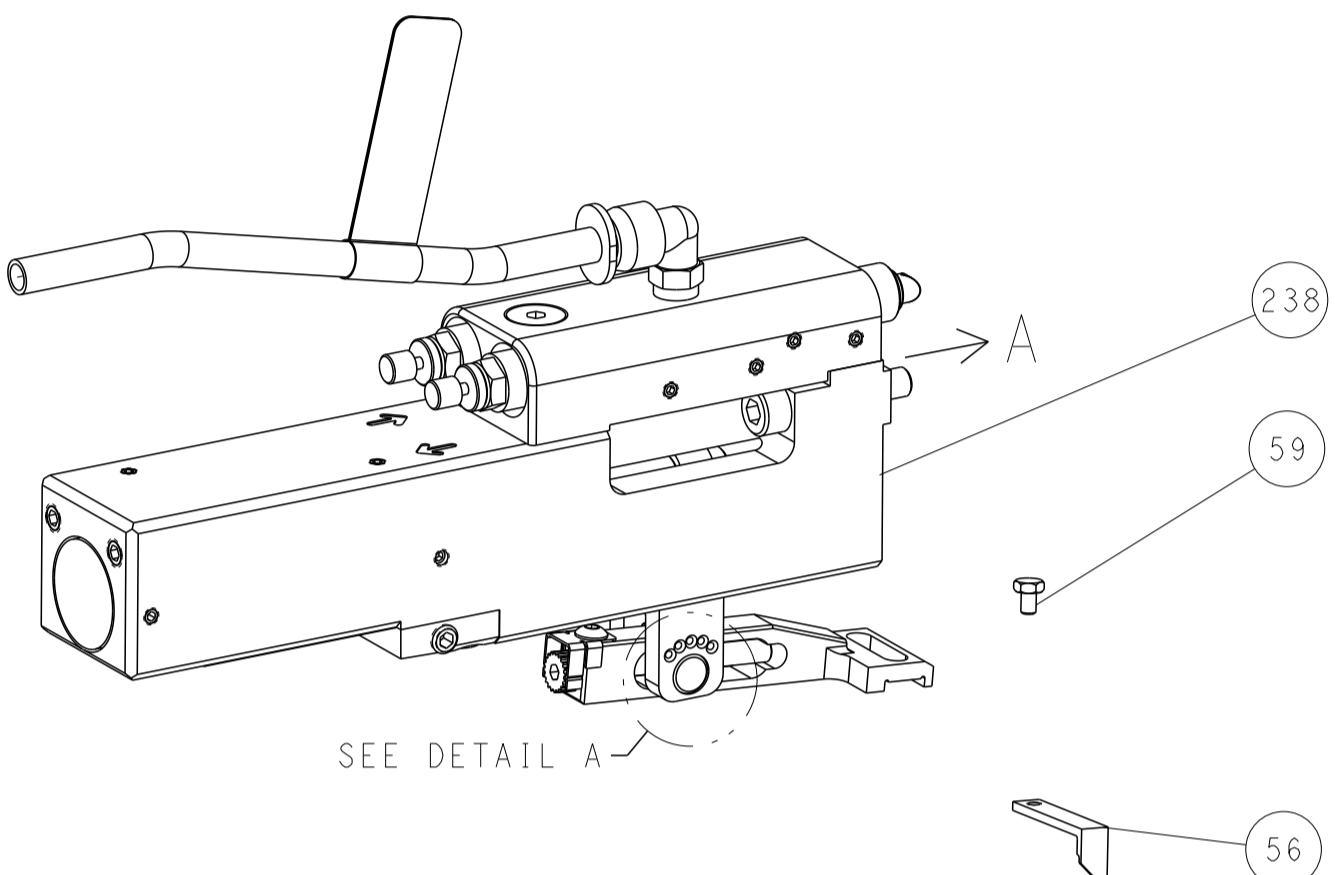

FEED SPRING SETTING POSITION (SHOWN FROM REAR SIDE)

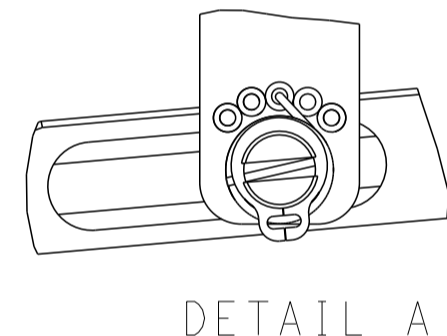

CAM POSITIONS

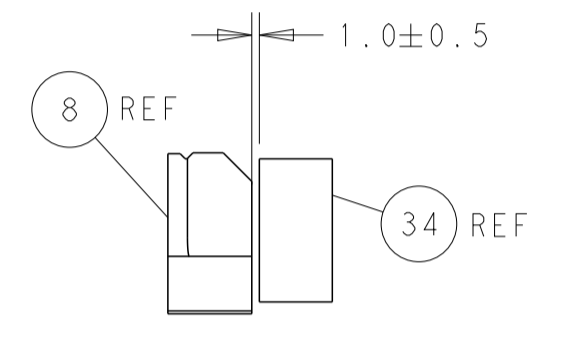
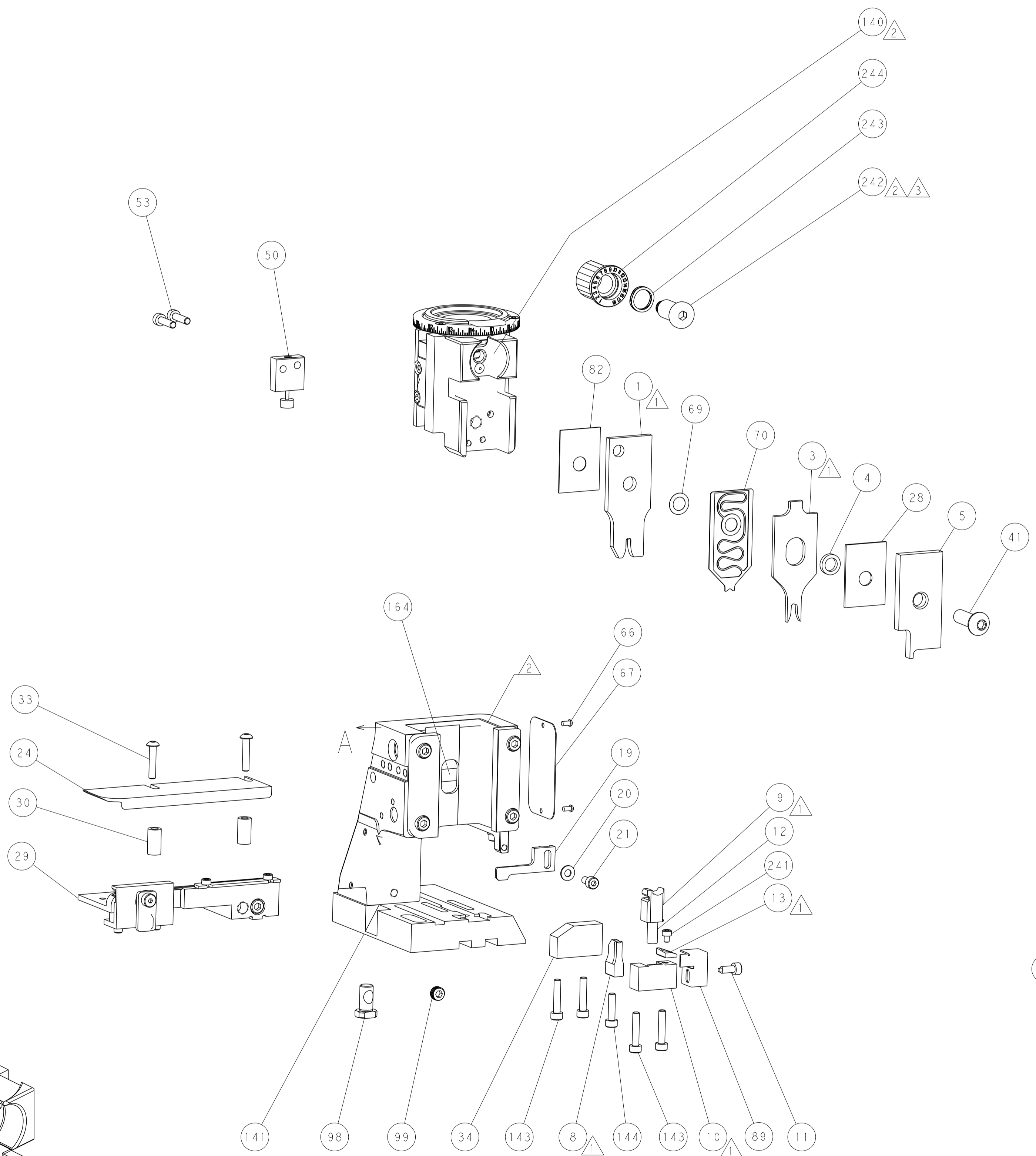
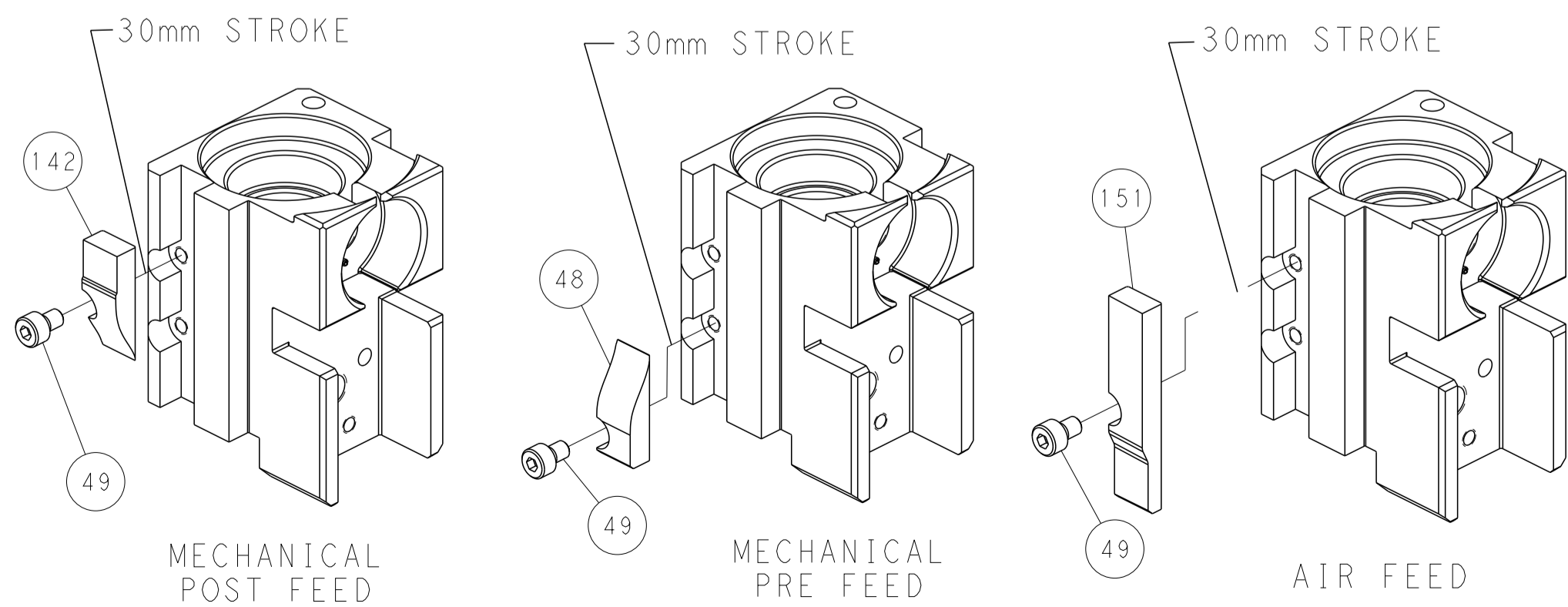

TERMINAL SUPPORT LOCATION

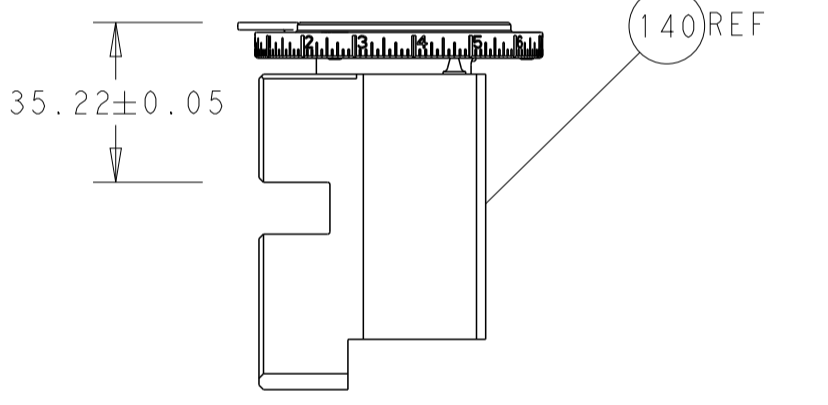

RAM SET-UP

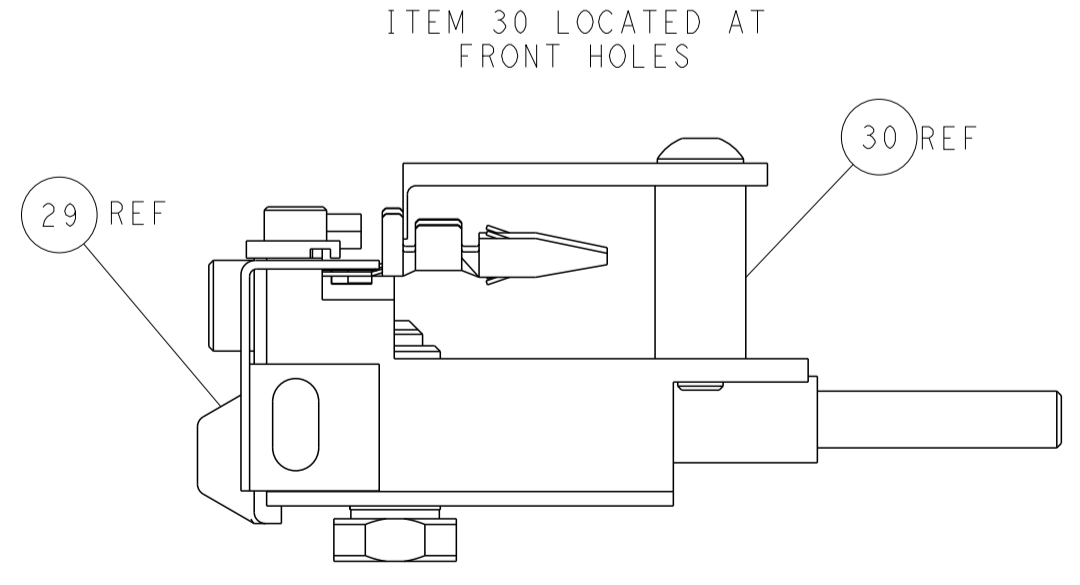

ITEM 30 LOCATED AT FRONT HOLES

FEED TRACK POSITION GUIDE BY INSULATION BARREL

PACIFIC VERSION
 Shown on sheets 3 of 4 & 4 of 4
 (Atlantic version shown on sheets 1 of 4 & 2 of 4)

DIMENSIONS:		TOLERANCES UNLESS OTHERWISE SPECIFIED:		DWN: H. HUANG 25OCT2013		TE Connectivity	
mm	0 PLC ±0.5	1 PLC ±0.5	2 PLC ±0.13	3 PLC ±0.013	4 PLC ±0.001	APVD: L. ZHANG 25OCT2013	Harrisburg, PA 17105-3608
MATERIAL:		FINISH:		NAME: Ocean Side Feed Applier		RESTRICTED TO:	
				SIZE: A1		CAGE CODE: 00779	
				DRAWING NO: C=2266087		SCALE: 1:2	
				SHEET: 4		OF: 4	
				REV: C			