

| REVISIONS |     |                           |           |     |      |
|-----------|-----|---------------------------|-----------|-----|------|
| P         | LTR | DESCRIPTION               | DATE      | DWN | APVD |
| B3        |     | REVISED PER ECR-23-176064 | 31MAY2023 | DB  | RE   |

# SUGGESTED MATING TAB

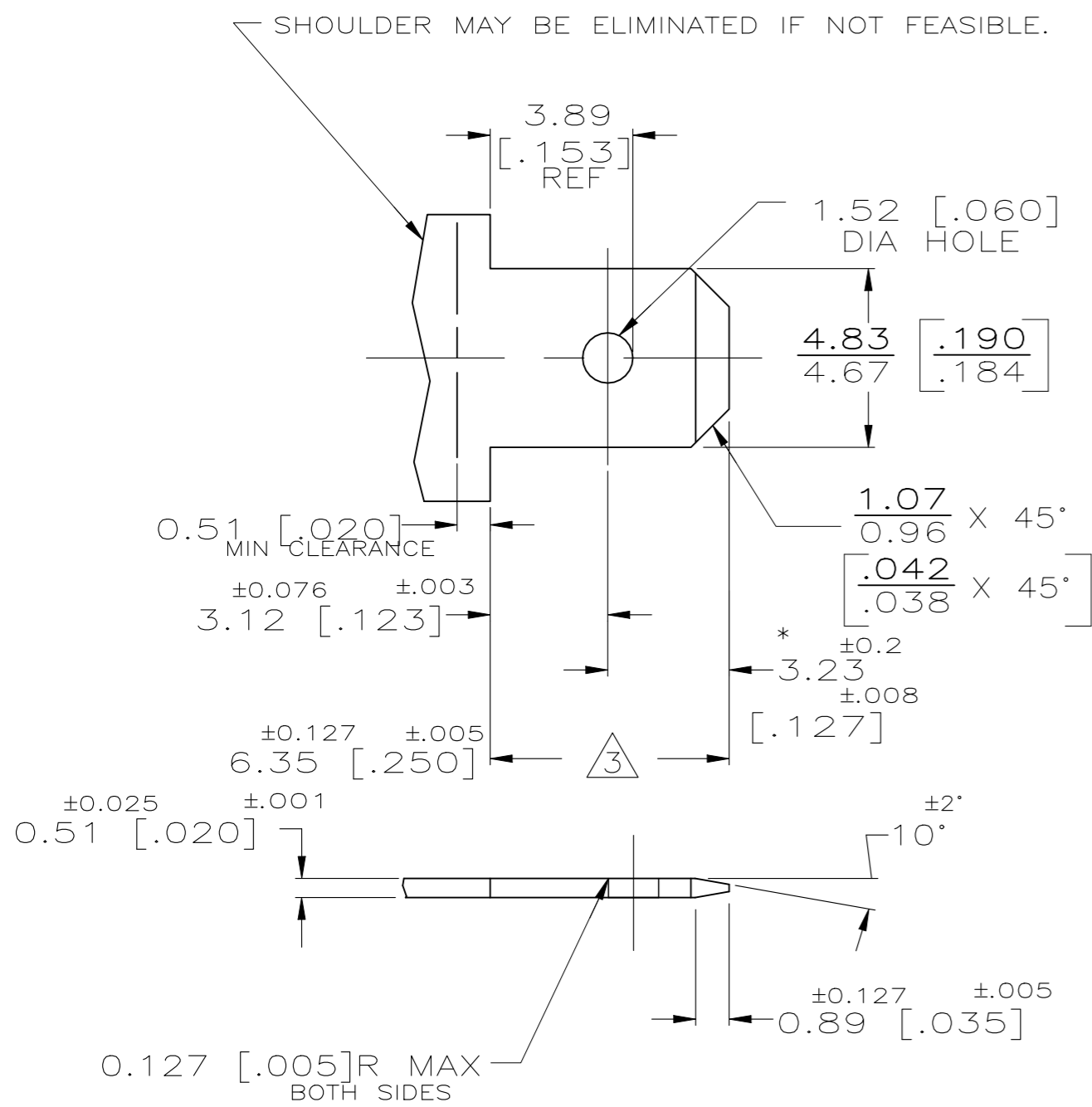

- 1 - MATL: 1/2H BRASS OR NICKEL PL STEEL.
- 2 - NO BURRS PERMISSIBLE AT HOLE.
- 3 - MUST BE FLAT WITHIN 0.076 [.003] OVER THIS LENGTH.
- 4 - HOLE MUST BE SYMMETRICAL ABOUT TAB  $\varnothing$  WITHIN 0.076 [.003]
- \* TO BE USED ONLY WHEN SHOULDER IS ELIMINATED.

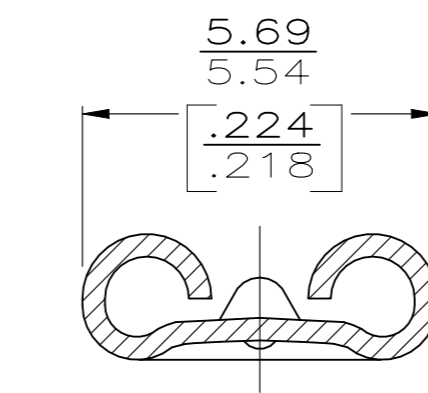
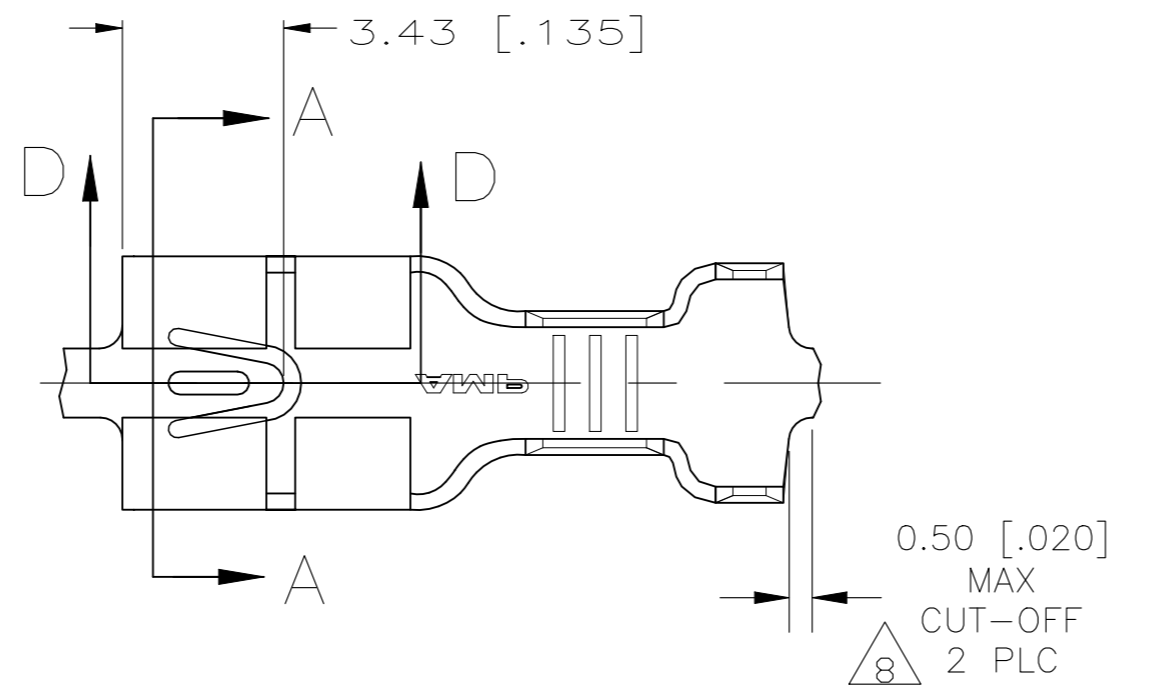

SECTION A-A  
SCALE 8:1

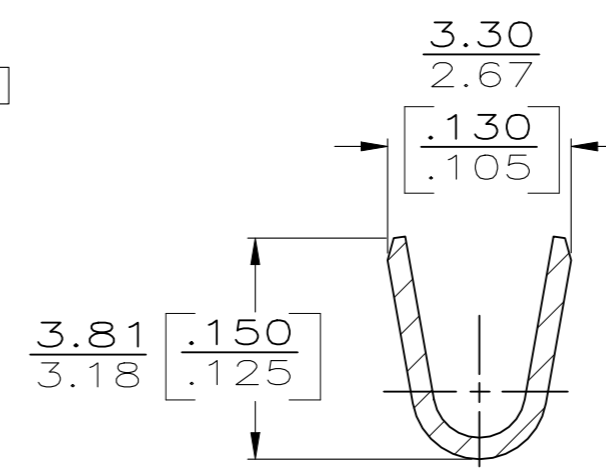
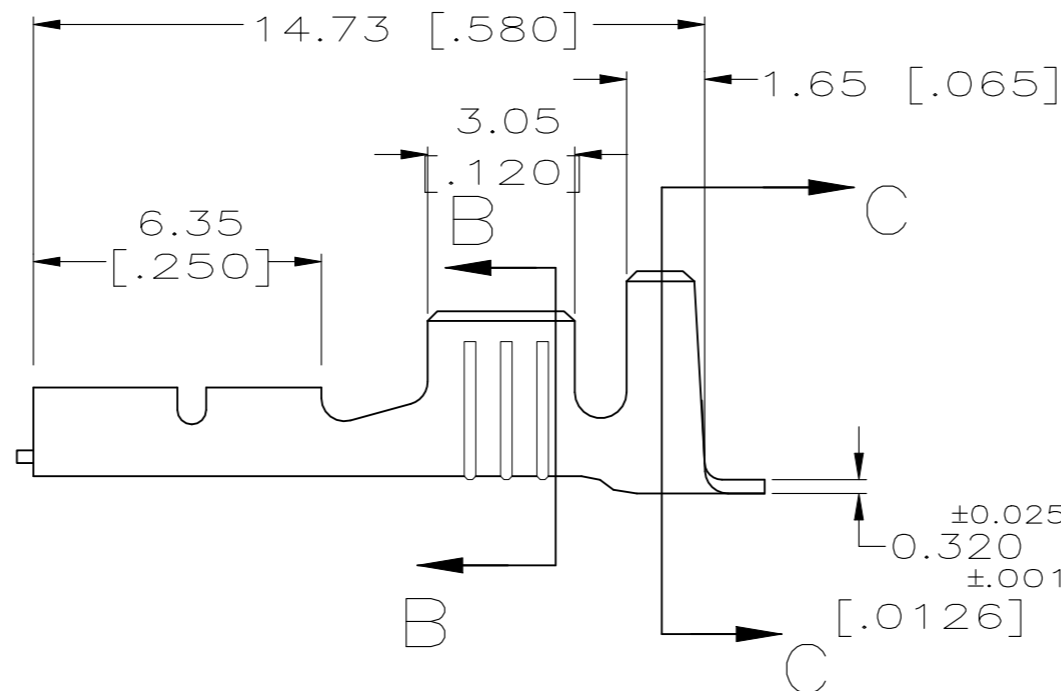

SECTION B-B  
SCALE 8:1

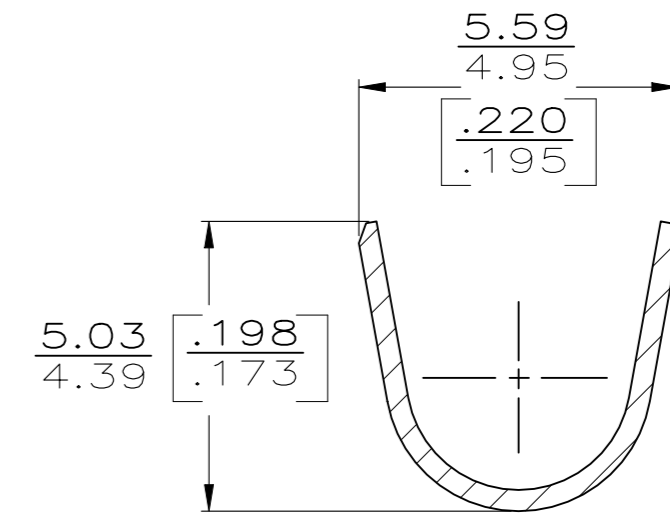

SECTION C-C  
SCALE 8:1

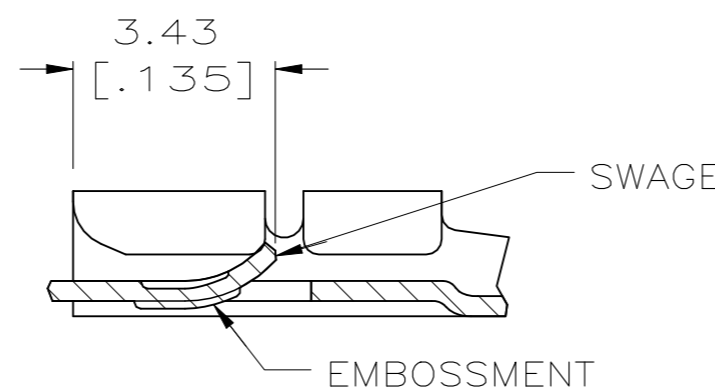

SECTION D-D  
SCALE 8:1

| TYPE               | WIDTH       | STRIP LENGTH  | TYPE              | WIDTH       | WIRE HEIGHT                         |
|--------------------|-------------|---------------|-------------------|-------------|-------------------------------------|
| F                  | 4.57 [.180] | 4.78 [.188]   | F                 | 2.29 [.090] | 1.85 [.073] 2.0mm <sup>2</sup> [14] |
|                    |             |               |                   |             | 1.57 [.062] 1.3mm <sup>2</sup> [16] |
|                    |             |               |                   |             | 1.40 [.055] 0.8mm <sup>2</sup> [18] |
|                    |             | ±0.38 [±0.15] |                   |             | ±0.051 [±0.002]                     |
| INSUL BARREL CRIMP |             |               | WIRE BARREL CRIMP |             |                                     |

|  |                  |                         |   |                 |                      |           |       |   |     |       |   |             |       |   |     |       |   |     |        |   |   |              |
|--|------------------|-------------------------|---|-----------------|----------------------|-----------|-------|---|-----|-------|---|-------------|-------|---|-----|-------|---|-----|--------|---|---|--------------|
| THIS DRAWING IS A CONTROLLED DOCUMENT.   |                  | DWN Senthil 08MAR2013   |   |                 | 2178549-3            |           |       |   |     |       |   |             |       |   |     |       |   |     |        |   |   |              |
| DIMENSIONS: MM [INCHES]  |                  | CHK RAJENDRA 08MAR2013  |   |                 | BRASS                | 2178549-2 |       |   |     |       |   |             |       |   |     |       |   |     |        |   |   |              |
| TOLERANCES UNLESS OTHERWISE SPECIFIED:   |                  | APVD RAJENDRA 08MAR2013 |   |                 | NONE                 | 2178549-1 |       |   |     |       |   |             |       |   |     |       |   |     |        |   |   |              |
| <table border="1"> <tr><td>0 PLC</td><td>±</td><td>[ ]</td></tr> <tr><td>1 PLC</td><td>±</td><td>[ ]</td></tr> <tr><td>2 PLC</td><td>±</td><td>0.25 [.010]</td></tr> <tr><td>3 PLC</td><td>±</td><td>[ ]</td></tr> <tr><td>4 PLC</td><td>±</td><td>[ ]</td></tr> <tr><td>ANGLES</td><td>±</td><td>-</td></tr> </table> |                  | 0 PLC                   |   |                 | ±                    | [ ]       | 1 PLC | ± | [ ] | 2 PLC | ± | 0.25 [.010] | 3 PLC | ± | [ ] | 4 PLC | ± | [ ] | ANGLES | ± | - | PRODUCT SPEC |
| 0 PLC  | ±                | [ ]                     |   |                 |                      |           |       |   |     |       |   |             |       |   |     |       |   |     |        |   |   |              |
| 1 PLC  | ±                | [ ]                     |   |                 |                      |           |       |   |     |       |   |             |       |   |     |       |   |     |        |   |   |              |
| 2 PLC  | ±                | 0.25 [.010]             |   |                 |                      |           |       |   |     |       |   |             |       |   |     |       |   |     |        |   |   |              |
| 3 PLC  | ±                | [ ]                     |   |                 |                      |           |       |   |     |       |   |             |       |   |     |       |   |     |        |   |   |              |
| 4 PLC  | ±                | [ ]                     |   |                 |                      |           |       |   |     |       |   |             |       |   |     |       |   |     |        |   |   |              |
| ANGLES   | ±                | -                       |   |                 |                      |           |       |   |     |       |   |             |       |   |     |       |   |     |        |   |   |              |
| MATERIAL SEE TABLE   | FINISH SEE TABLE | APPLICATION SPEC        | RECTPT, FASTON, LOCK-ON, 4.75 [.187] SERIES |                 |                      |           |       |   |     |       |   |             |       |   |     |       |   |     |        |   |   |              |
|  |                  | WEIGHT 0.000000         | SIZE A2                                     | CAGE CODE 00779 | DRAWING NO C=2178549 |           |       |   |     |       |   |             |       |   |     |       |   |     |        |   |   |              |
|  |                  | CUSTOMER DRAWING        | SCALE 6:1                                   | SHEET 1 OF 1    | REV B3               |           |       |   |     |       |   |             |       |   |     |       |   |     |        |   |   |              |