

PART NUMBER	REVISION	DESCRIPTION	FEED TYPE
2151739-2	E	FINE CRIMP HEIGHT ADJUST	PNEUMATIC
7-2151739-2	E	PNEUMATIC AND CRIMP TOOLING KIT	PNEUMATIC
7-2151739-7	B	CRIMP TOOLING KIT	-

ATLANTIC VERSION TERMINATOR INTERFACE ADAPTER

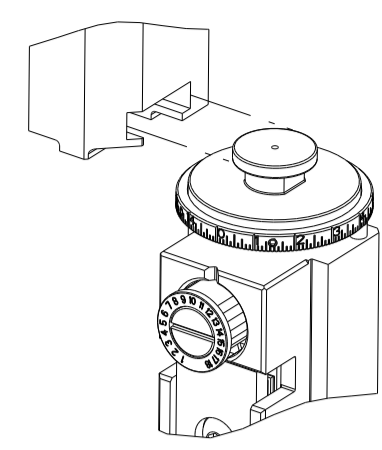

APPLICATOR DATA		
CRIMP	SIZE	TYPE
WIRE	3.89 mm [.153]	F
INSUL	-	-

APPLICATOR INSTRUCTIONS 408-35042

TERMINAL DATA: TE TERMINAL		TE CRIMP SPECIFICATION	
TERMINAL NAME: PV4 CONNECTOR PIN AND SOCKET			
WIRE STRIP LENGTH		INSULATION DIAMETER RANGE	
4.58-4.96 mm [.180-.195 IN]		∅ -	-
TERMINAL APPLICATION SPECIFICATION		114-137077	-
TERMINALS APPLIED			
TE TERMINAL	TE TERMINAL	TE TERMINAL	TE TERMINAL
2270251-2	2270226-2	2363117-2	2363118-2

WIRE SIZE	CRIMP HEIGHT mm [INCH]	CRIMP HEIGHT REFERENCE SETTING
10 AWG OR 6.00mm2	2.49 +/- 0.05 [.098 +/- .002]	2.2
12 AWG OR 4.00mm2	2.14 +/- 0.05 [.084 +/- .002]	5.8

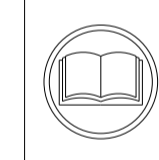

- 1 RECOMMENDED SPARE PARTS
- 2 REFER TO SUPPLIED INSTRUCTION SHEET FOR CLEANING, LUBRICATION AND STORAGE OF APPLICATOR.
- 3 CRIMP HEIGHT REFERENCE SETTING WAS THE SETTING USED WHEN THE APPLICATOR WAS QUALIFIED AT THE FACTORY. ADJUSTMENT MAY BE NECESSARY WHEN RUNNING APPLICATOR IN THE FIELD.
- 4 TERMINAL PITCH NOT COMPATIBLE WITH MECHANICAL FEED.
- 5. UNLESS SPECIFIED OTHERWISE TORQUE VALUES SHALL BE USED PER DOCUMENT, 101-35000.
- 6 TERMINAL LUBRICANT IS RECOMMENDED.

***WARNING**
 ON INSTALLATION, SET WIRE DISC TO CRIMP HEIGHT REFERENCE SETTING FOR LARGEST WIRE SIZE. CRIMP HEIGHT REFERENCE SETTINGS GREATER THAN THE VALUE SHOWN MAY CAUSE DAMAGE TO THE CRIMP TOOLING. REFER TO THE INSTRUCTION SHEET FOR PROPER SETUP AND ADJUSTMENTS.

ATLANTIC VERSION
 Shown on sheets 1 of 4 & 2 of 4
 (Pacific version shown on sheets 3 of 4 & 4 of 4)

LOC	DIST	REVISIONS					
A	66	P	LTN	DESCRIPTION	DATE	OWN	APVD
		D		ECR-20-014423	12OCT2020	FJ	TE
		D1		ECR-21-003293	17MAR2021	FZ	GB
		E		ECR-21-118593	25OCT2021	TB	RK
		E1		ECR-21-120795	15NOV2021	FZ	TE

-	1	1	2119641-1	FEED CAM, AIR FEED	248
-	1	1	7-18023-7	SCR, SKT HD CAP M3 X 4.0	241
-	1	1	2844940-1	AIR FEED MODULE	238
-	REF	REF	994970-2	COUNTER, MAGNETIC	164
-	1	1	318563-1	GUARD, FRONT CHIP	119
-	1	1	2119955-1	ASSY, LUBRICATOR, SIDE FEED	113
-	1	1	2844908-1	SCREW, LOCKING	99
-	1	1	2844907-1	POST, LOCKING	98
-	1	1	455888-5	SPACER, CRIMPER	82
-	2	2	2079383-4	SCR, BHSC, RoHS (M4 X 8)	79
-	1	1	1803096-1	EXTENSION PLATE	78
-	1	1	1803607-3	DOCUMENTATION PACKAGE	71
-	1	1	2119740-1	TAG, IDENTIFICATION	67
-	2	2	2168078-1	SCREW, DRIVE, RH, RoHS, 2 x .188	66
-	1	1	2168083-2	SCR, SKT HD CAP, RoHS, M4 X 8.0	60
-	1	1	5-18022-5	SCR, HEX HD CAP, M4 X 6.0	59
-	1	1	1338685-1	PAWL, FEED	56
-	4	4	2168083-3	SCR, SKT HD CAP, RoHS, M4 X 12.0	54
-	2	2	2-2168083-5	SCR, SKT HD CAP, RoHS, M4 X 14	53
-	1	1	5018030-1	NUT, HEX, REG, RoHS, M3	52
-	1	1	811242-5	BUMPER, HOLD DOWN	51
-	1	1	690753-2	SPACER, TONKER	50
-	1	1	18023-9	SCR, SKT HD CAP M4 X 6.0	49
-	1	1	1803583-9	APPLICATOR BASIC ASSEMBLY, SF	46
-	1	1	1803515-1	RAM ASSEMBLY, SF ATLANTIC	44
-	1	1	1803602-1	SCR, BHSC, RoHS (M8 X 25)	41
-	1	1	3-1752356-3	SUPPORT, TERMINAL	34
-	2	2	2079383-5	SCR, BHSC, RoHS (M4 X 20)	33
-	2	2	2-2844962-0	SPACER, CYLINDRICAL, STRIP GUIDE	30
-	1	1	2844992-1	ASSEMBLY, STRIP GUIDE	29
-	1	1	1-455888-0	SPACER, CRIMPER	28
-	1	1	1320928-4	STRIP GUIDE	24
-	1	1	1-18028-2	WASHER, FLAT, REG M4	22
-	1	1	2168083-2	SCR, SKT HD CAP, RoHS, M4 X 8.0	21
-	1	1	2119533-1	STRIPPER, SIDE FEED	19
-	1	1	2119806-1	INSERT, SHEAR	13
-	1	1	3-22280-3	SPRING, COMPRESSION	12
-	1	1	1-356885-4	STOP, SHEAR	11
-	1	1	2119805-1	SHEAR HOLDER, FRONT	10
-	1	1	454276-5	FLOATING SHEAR, FRONT	9
-	1	2	1-1633933-9	ANVIL, COMBINATION	8
-	1	1	240641-5	SPACER	7
-	-	-	-	-	6
-	1	1	1-2119757-1	DEPRESSOR, SHEAR	5
-	-	-	-	-	4
-	-	-	-	-	3
-	-	-	-	-	2
-	1	2	1-9-1633609-2	CRIMPER, WIRE	1

<small>THIS DRAWING IS A CONTROLLED DOCUMENT. ANY REVISIONS TO THIS DRAWING SHALL BE CONTROLLED THROUGH THE APPLICABLE ORGANIZATION. SHOULD BE CONTACTED FOR THE LATEST REVISION.</small>		DWN BOB HIGMAN 01JAN2012 CHK T. ELBIN 01JAN2012 APVD T. ELBIN 01JAN2012	TE Connectivity Harrisburg, PA 17105-3608
DIMENSIONS: mm 		TOLERANCES UNLESS OTHERWISE SPECIFIED: 0 PLC ± 1 PLC ± 2 PLC ± 3 PLC ± 4 PLC ± ANGLES ± FINISH	NAME Ocean Side Feed Applicator SIZE CAGE CODE DRAWING NO RESTRICTED TO A1 00779 C=2151739 Customer Accessible Production Drawing SCALE 1:2 SHEET 1 OF 4 REV E1

LOC	DIST	REVISIONS					
		P	LTN	DESCRIPTION	DATE	OWN	APVD
A	66	-	-	SEE SHEET 1	-	-	-

FEED TYPE

PNEUMATIC

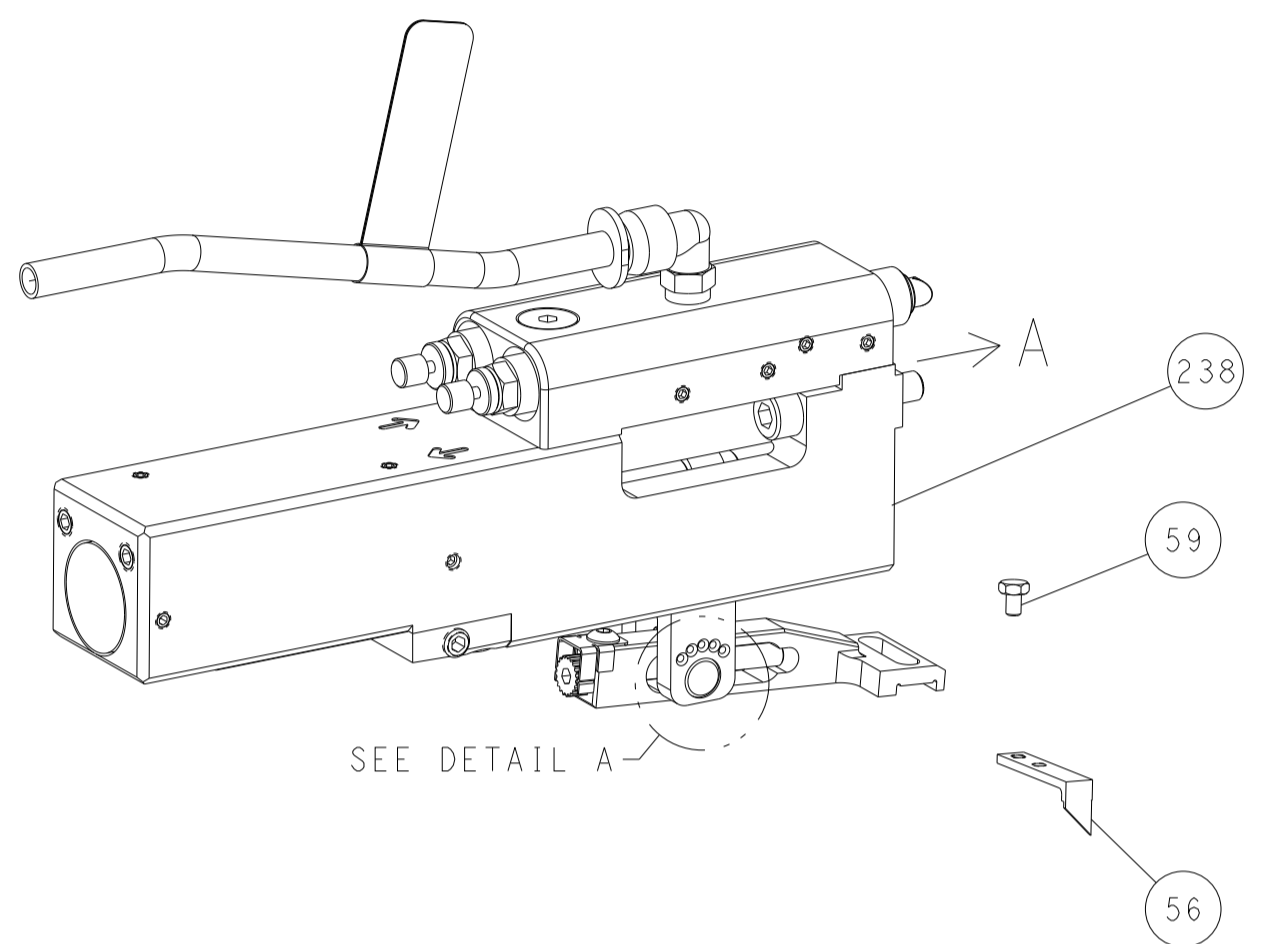

FEED SPRING SETTING POSITION (SHOWN FROM REAR SIDE)

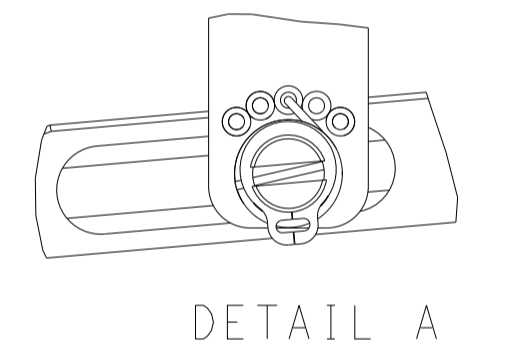

DETAIL A

CAM POSITION

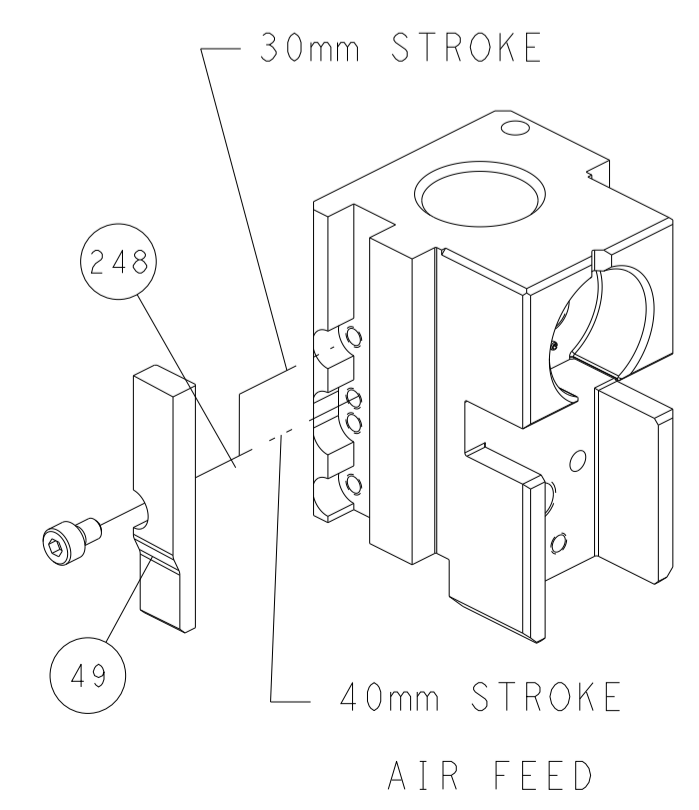

AIR FEED

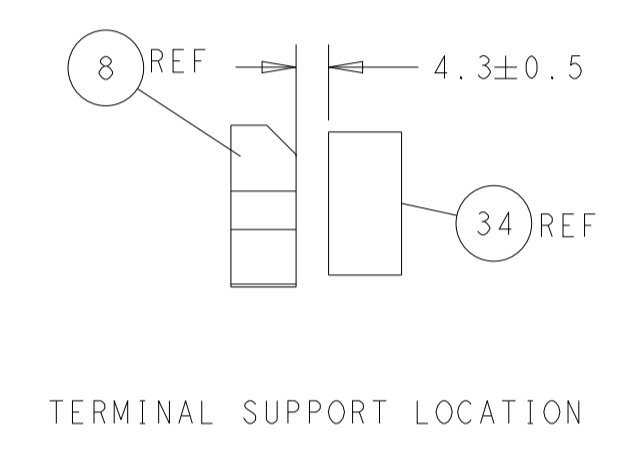
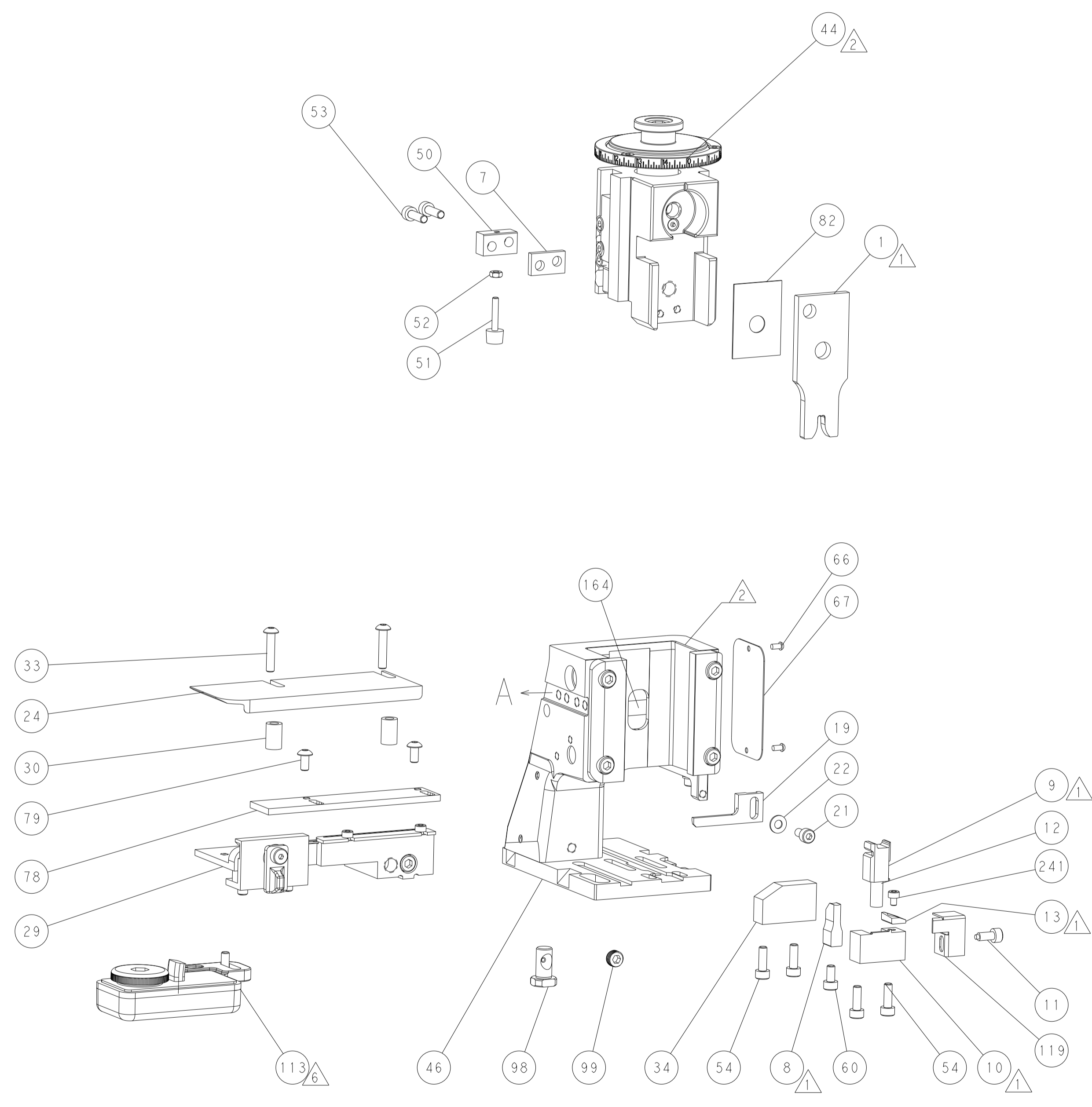

TERMINAL SUPPORT LOCATION

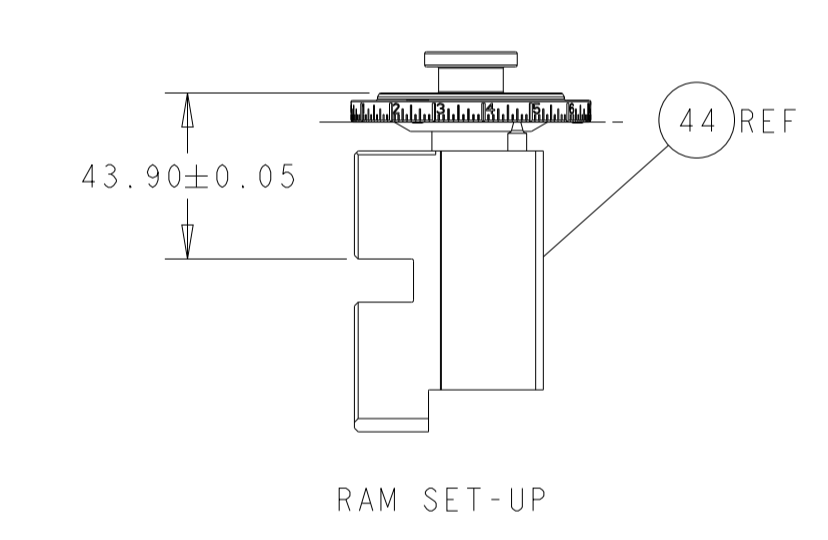

RAM SET-UP

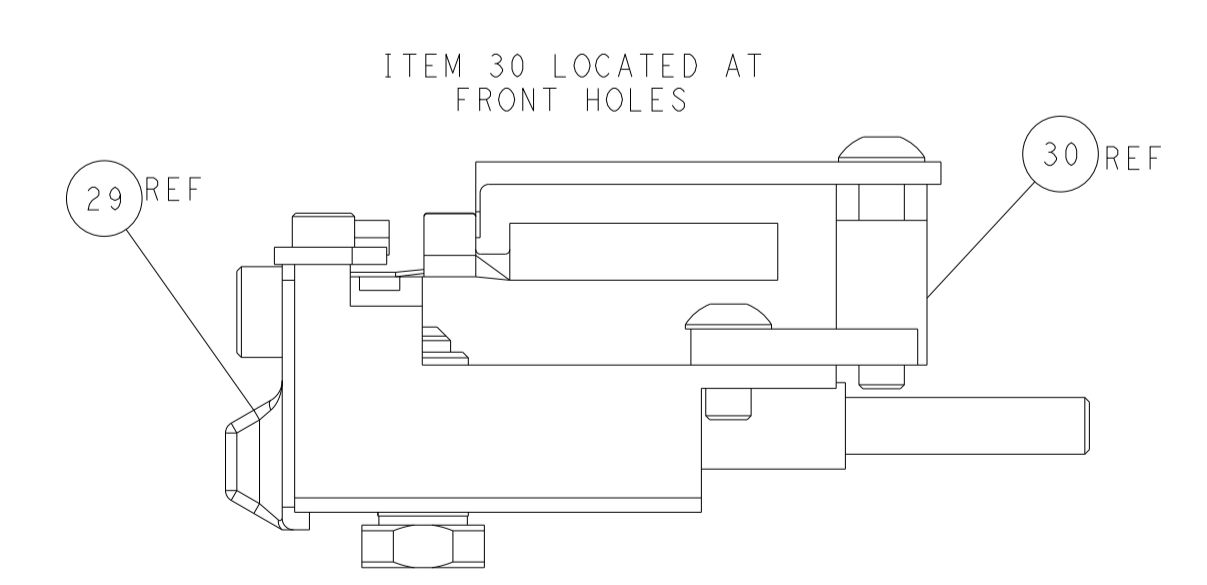

FEED TRACK POSITION GUIDE BY WIRE BARREL

ATLANTIC VERSION
 Shown on sheets 1 of 4 & 2 of 4
 (Pacific version shown on sheets 3 of 4 & 4 of 4)

<small>THIS DRAWING IS UNPUBLISHED. RELEASED FOR PUBLICATION 20. COPYRIGHT 20 BY TYCO ELECTRONICS CORPORATION. ALL RIGHTS RESERVED.</small>		DWN BOB HIGMAN 01JAN2012 CHK T. ELBIN 01JAN2012 APVD T. ELBIN 01JAN2012	TE Connectivity Harrisburg, PA 17105-3608
DIMENSIONS: mm TOLERANCES UNLESS OTHERWISE SPECIFIED: 0 PLC ± 1 PLC ± 2 PLC ± 3 PLC ± 4 PLC ± ANGLES ± FINISH ±		NAME Ocean Side Feed Applicator PRODUCT SPEC APPLICATION SPEC SIZE CAGE CODE DRAWING NO. RESTRICTED TO A1 00779 ©=2151739	WEIGHT SCALE 1:2 SHEET 2 OF 4 REV E1
MATERIAL:		Customer Accessible Production Drawing	

PART NUMBER	REVISION	DESCRIPTION	FEED TYPE
2-2151739-2	E	FINE CRIMP HEIGHT ADJUST	PNEUMATIC
7-2151739-7	B	CRIMP TOOLING KIT	-

PACIFIC VERSION TERMINATOR
 INTERFACE ADAPTER

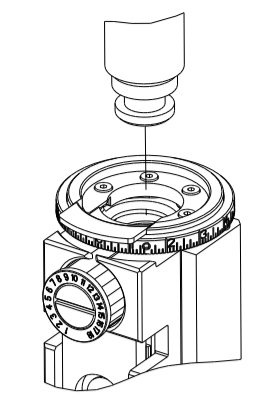

APPLICATOR DATA		
CRIMP	SIZE	TYPE
WIRE	3.89 mm [1.53]	F
INSUL	-	-

APPLICATOR INSTRUCTIONS
 408-35042

TERMINAL DATA: TE TERMINAL		TE CRIMP SPECIFICATION	
TERMINAL NAME: PV4 CONNECTOR PIN AND SOCKET			
WIRE STRIP LENGTH		INSULATION DIAMETER RANGE	
4.58-4.96 mm [1.80-.195 IN]		Ø -	
TERMINAL APPLICATION SPECIFICATION		114-137077	
TERMINALS APPLIED			
TE TERMINAL	TE TERMINAL	TE TERMINAL	TE TERMINAL
2270251-2	2270226-2	2363117-2	2363118-2

WIRE SIZE	CRIMP HEIGHT mm [INCH]	CRIMP HEIGHT REFERENCE SETTING
10 AWG OR 6.00mm ²	2.49+/-0.05 [1.098+/-0.002]	2.2
12 AWG OR 4.00mm ²	2.14+/-0.05 [1.084+/-0.002]	5.8

- 1 RECOMMENDED SPARE PARTS
- 2 REFER TO SUPPLIED INSTRUCTION SHEET FOR CLEANING, LUBRICATION AND STORAGE OF APPLICATOR.
- 3 CRIMP HEIGHT REFERENCE SETTING WAS THE SETTING USED WHEN THE APPLICATOR WAS QUALIFIED AT THE FACTORY. ADJUSTMENT MAY BE NECESSARY WHEN RUNNING APPLICATOR IN THE FIELD.
- 4 TERMINAL PITCH NOT COMPATIBLE WITH MECHANICAL FEED.
- 5. UNLESS SPECIFIED OTHERWISE TORQUE VALUES SHALL BE USED PER DOCUMENT, 101-35000.
- 6 TERMINAL LUBRICANT IS RECOMMENDED.

***WARNING**
 ON INSTALLATION, SET WIRE DISC TO CRIMP HEIGHT REFERENCE SETTING FOR LARGEST WIRE SIZE. CRIMP HEIGHT REFERENCE SETTINGS GREATER THAN THE VALUE SHOWN MAY CAUSE DAMAGE TO THE CRIMP TOOLING, REFER TO THE INSTRUCTION SHEET FOR PROPER SETUP AND ADJUSTMENTS.

PACIFIC VERSION
 Shown on sheets 3 of 4 & 4 of 4
 (Atlantic version shown on sheets 1 of 4 & 2 of 4)

LOC	DIST	REV	DATE	BY	APPV
A	66				

REV	DATE	BY	APPV	DESCRIPTION	DATE	BY	APPV
-	1	7-18023-7		SCR, SKT HD CAP M3 X 4.0			241
-	1	2844940-1		AIR FEED MODULE			238
-	REF	994970-2		COUNTER, MAGNETIC			164
-	1	2119641-2		FEED CAM, AIR FEED			151
-	1	2168083-8		SCR, SKT HD CAP, RoHS, M4 X 16			144
-	4	2168083-9		SCR, SKT HD CAP, RoHS, M4 X 20			143
-	1	1-1803583-0		APPLICATOR BASIC ASSEMBLY, SF			141
-	1	1803516-1		RAM ASSEMBLY, SF PACIFIC			140
-	1	318563-1		GUARD, FRONT CHIP			119
6	-	2119955-1		ASSY, LUBRICATOR, SIDE FEED			113
-	1	2844908-1		SCREW, LOCKING			99
-	1	2844907-1		POST, LOCKING			98
-	1	455888-5		SPACER, CRIMPER			82
-	2	2079383-4		SCR, BHSC, RoHS (M4 X 8)			79
-	1	1803096-1		EXTENSION PLATE			78
-	1	1803607-3		DOCUMENTATION PACKAGE			71
-	1	2119740-1		TAG, IDENTIFICATION			67
-	2	2168078-1		SCREW, DRIVE, RH, RoHS, 2 x .188			66
-	1	5-18022-5		SCR, HEX HD CAP, M4 X 6.0			59
-	1	1338685-1		PAWL, FEED			56
-	2	2-2168083-5		SCR, SKT HD CAP, RoHS, M4 X 14			53
-	1	5018030-1		NUT, HEX, REG, RoHS, M3			52
-	1	811242-5		BUMPER, HOLD DOWN			51
-	1	690753-2		SPACER, TONKER			50
-	1	18023-9		SCR, SKT HD CAP M4 X 6.0			49
-	1	1803602-1		SCR, BHSC, RoHS (M8 X 25)			41
-	1	3-1752356-3		SUPPORT, TERMINAL			34
-	2	2079383-5		SCR, BHSC, RoHS (M4 X 20)			33
-	2	2-2844962-0		SPACER, CYLINDRICAL, STRIP GUIDE			30
-	1	2844992-1		ASSEMBLY, STRIP GUIDE			29
-	1	1-455888-0		SPACER, CRIMPER			28
-	1	1320928-4		STRIP GUIDE			24
-	1	1-18028-2		WASHER, FLAT, REG M4			22
-	1	2168083-2		SCR, SKT HD CAP, RoHS, M4 X 8.0			21
-	1	2119533-1		STRIPPER, SIDE FEED			19
1	-	2119806-1		INSERT, SHEAR			13
-	1	3-22280-3		SPRING, COMPRESSION			12
-	1	1-356885-4		STOP, SHEAR			11
1	-	2119805-1		SHEAR HOLDER, FRONT			10
1	-	454276-5		FLOATING SHEAR, FRONT			9
1	1	2-1633933-9		ANVIL, COMBINATION			8
-	1	240641-5		SPACER			7
-	-	-		-			6
-	1	1-2119757-1		DEPRESSOR, SHEAR			5
-	-	-		-			4
-	-	-		-			3
-	-	-		-			2
1	1	9-1633609-2		CRIMPER, WIRE			1

DIMENSIONS:		TOLERANCES UNLESS OTHERWISE SPECIFIED:		MATERIAL:		WEIGHT:		SCALE:	
mm	0 PLC ±	1 PLC ±	2 PLC ±	3 PLC ±	4 PLC ±	ANGLES ±	FINISH	Customer Accessible Production Drawing	SCALE 1:2 SHEET 3 OF 4 REV E1

LOC		DIST		REVISIONS			
P	LTN	DESCRIPTION	DATE	OWN	APVD		
-	-	SEE SHEET 1	-	-	-		

FEED TYPE

PNEUMATIC

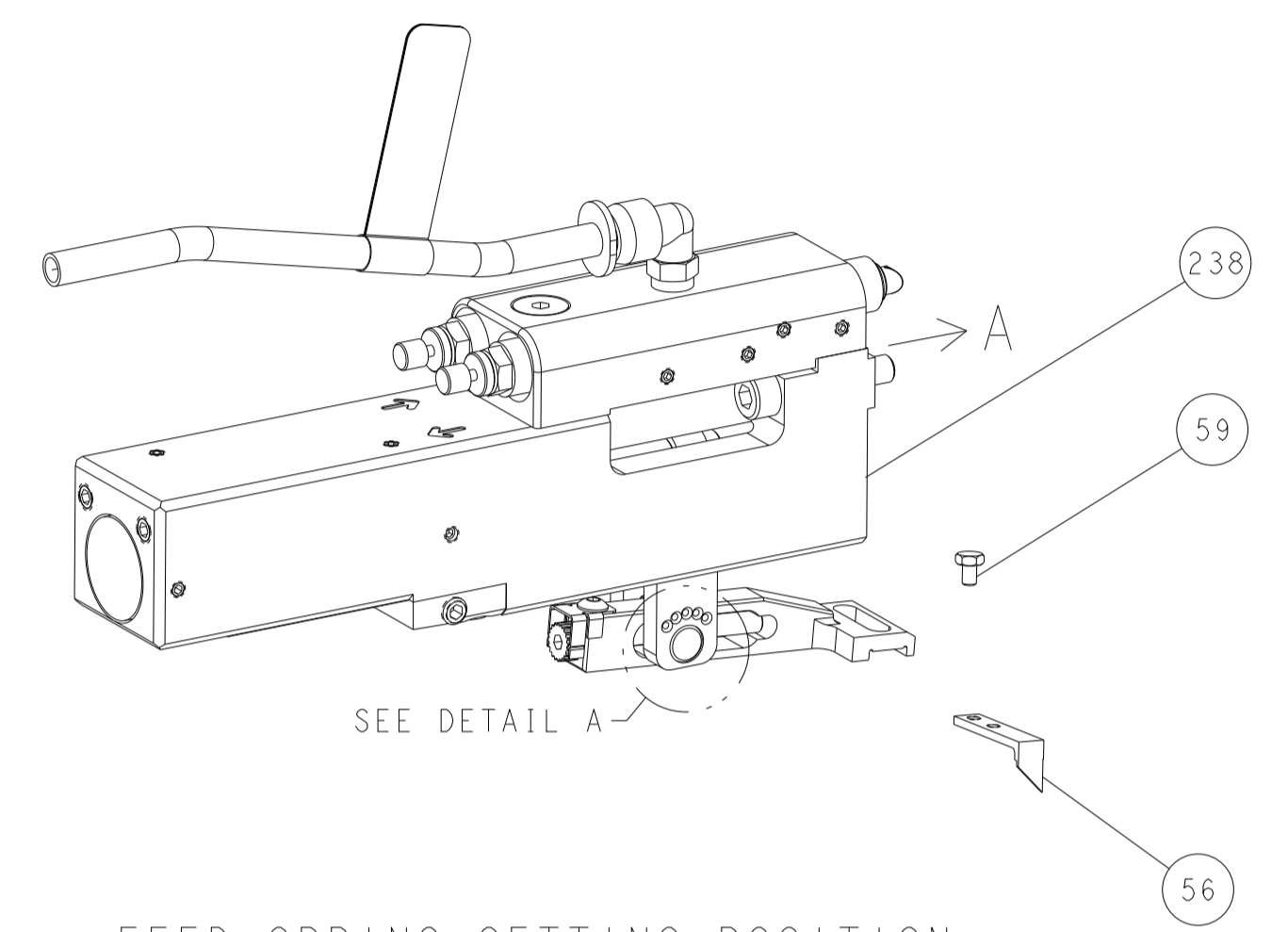

SEE DETAIL A

FEED SPRING SETTING POSITION
(SHOWN FROM REAR SIDE)

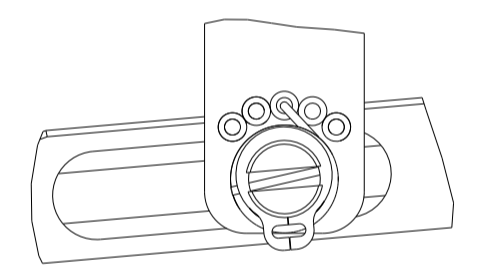

DETAIL A

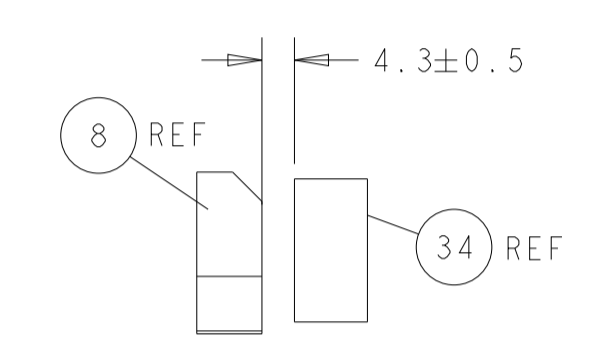
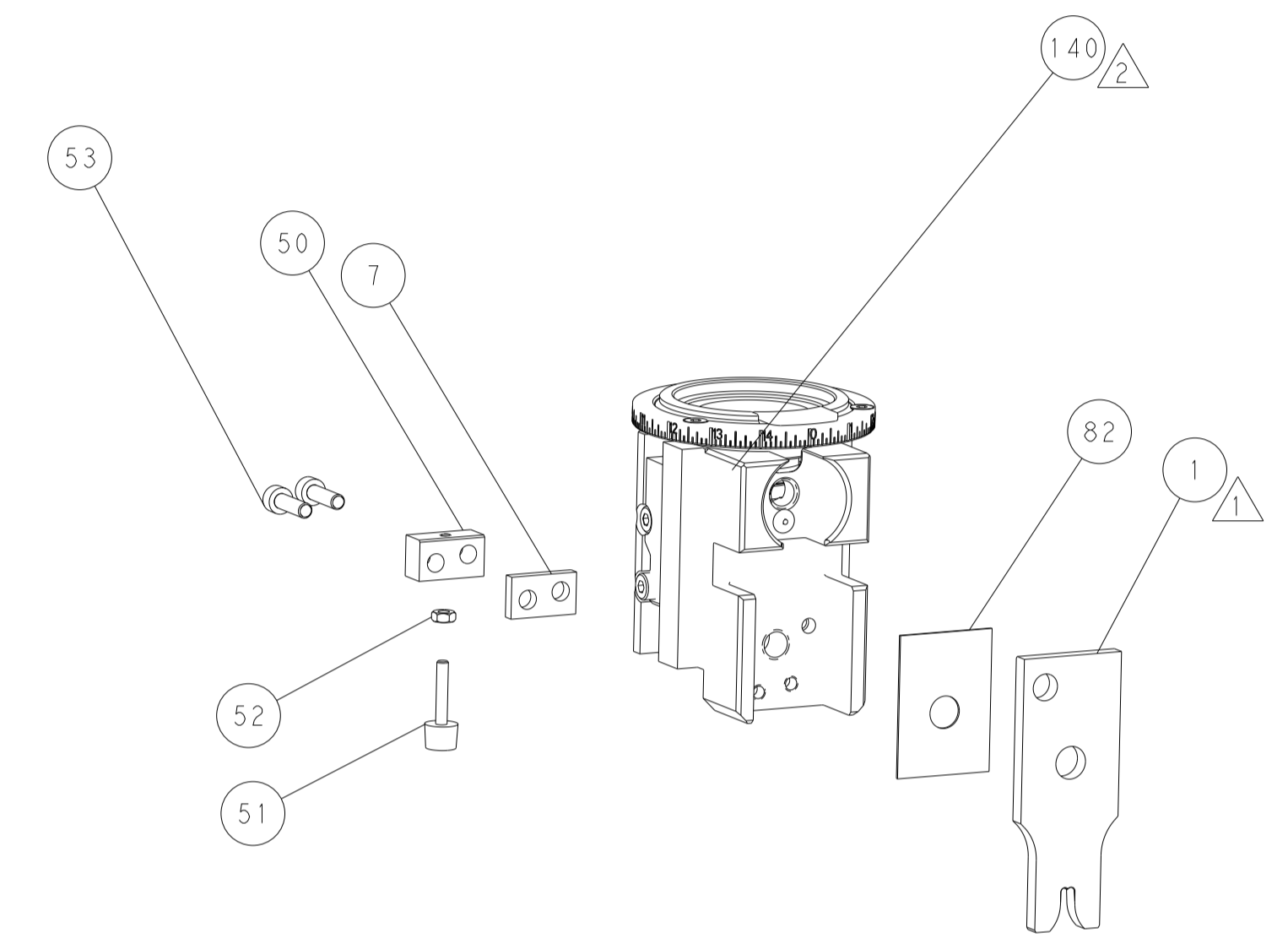

TERMINAL SUPPORT LOCATION

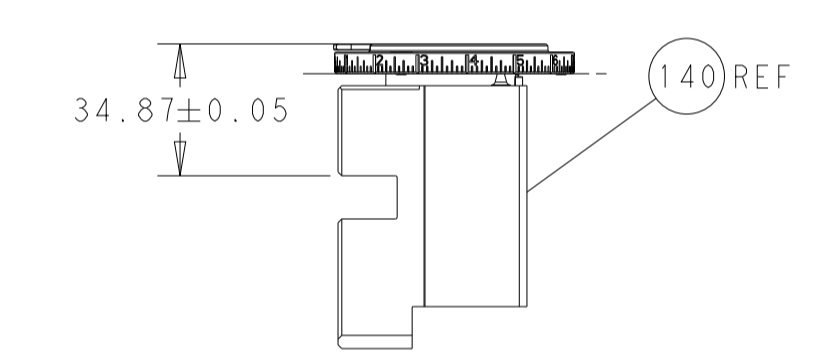
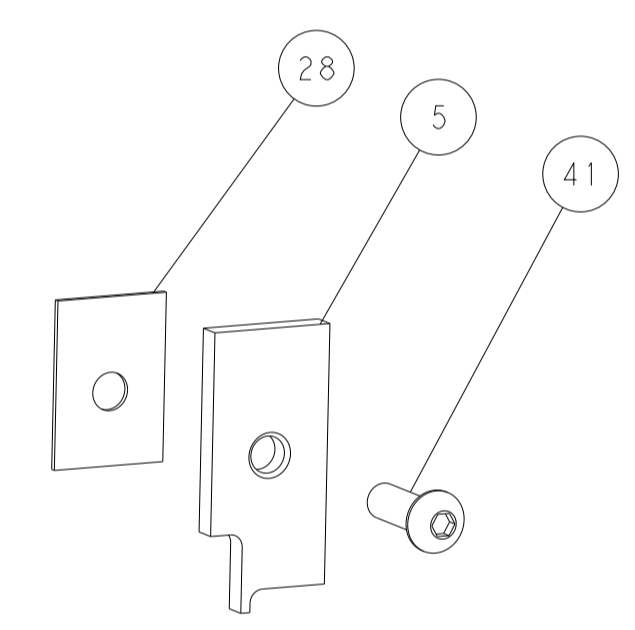

RAM SET-UP

CAM POSITION

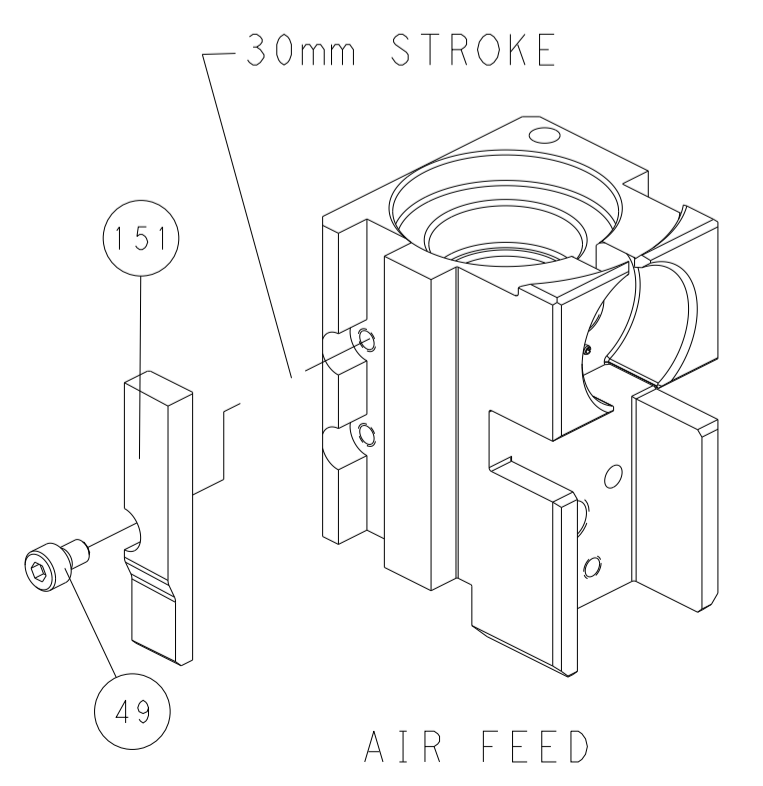

AIR FEED

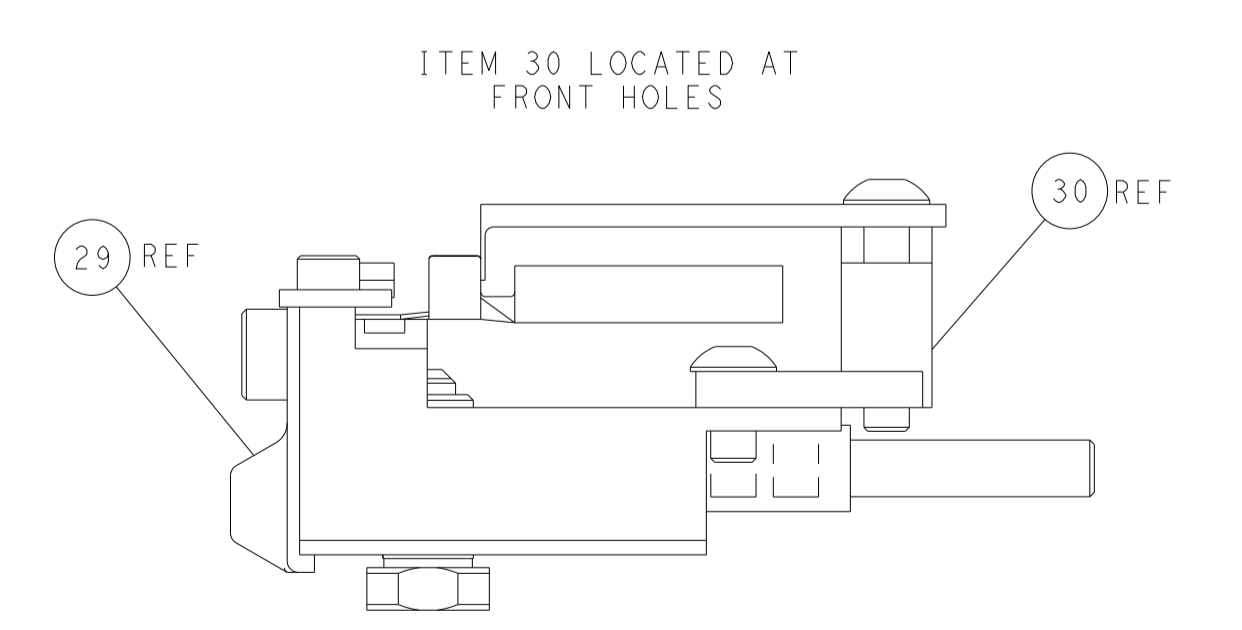
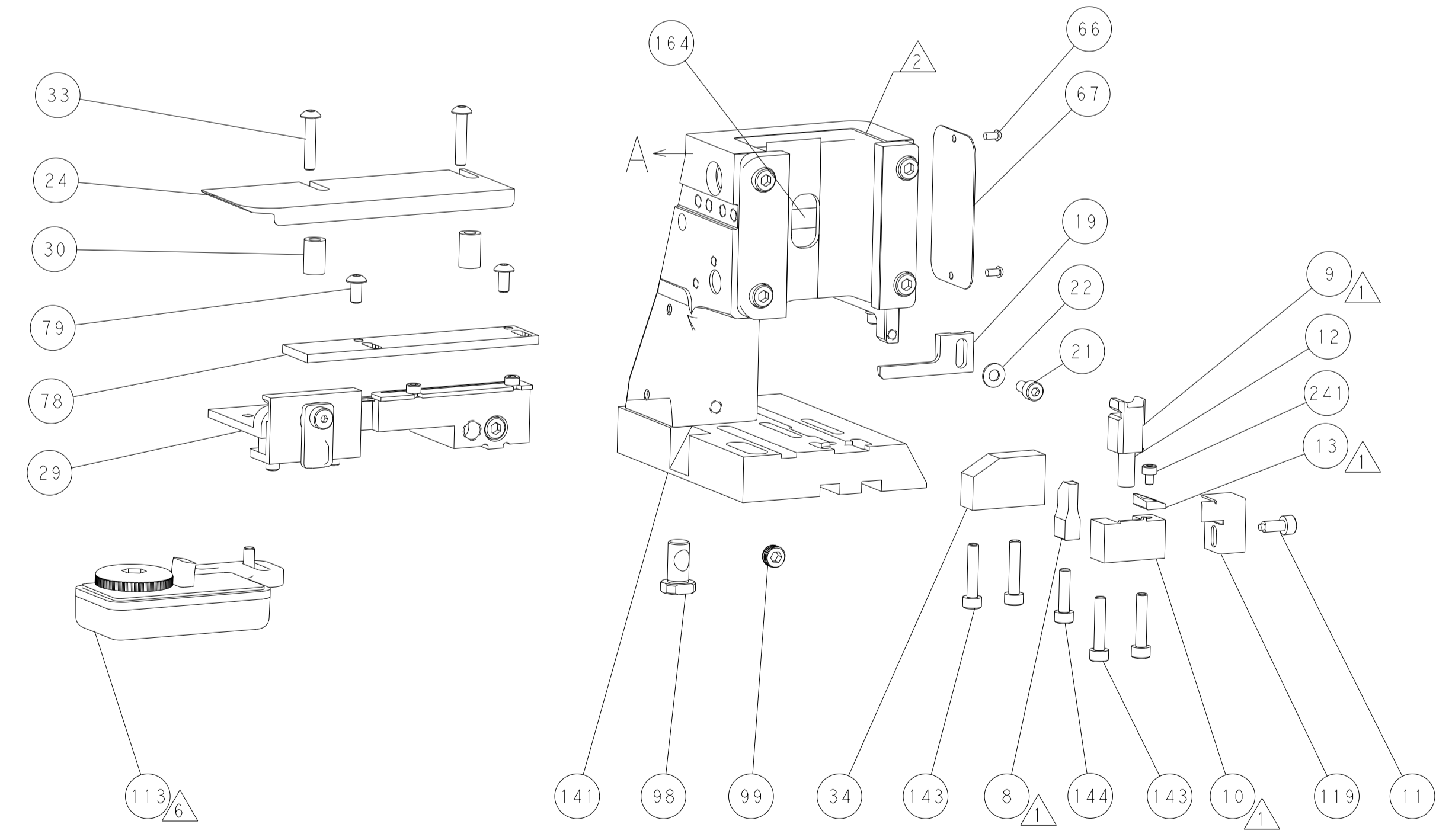

FEED TRACK POSITION
GUIDE BY WIRE BARREL

PACIFIC VERSION
 Shown on sheets 3 of 4 & 4 of 4
 (Atlantic version shown on sheets 1 of 4 & 2 of 4)

<small>THIS DRAWING IS A CONTROLLED DOCUMENT FOR TYCO ELECTRONICS CORPORATION. IT IS THE PROPERTY OF COMPANY AND IS NOT TO BE REPRODUCED OR TRANSMITTED IN ANY FORM OR BY ANY MEANS, ELECTRONIC OR MECHANICAL, INCLUDING PHOTOCOPYING, RECORDING, OR BY ANY INFORMATION STORAGE AND RETRIEVAL SYSTEM, WITHOUT THE WRITTEN PERMISSION OF TYCO ELECTRONICS CORPORATION.</small>		DWN BOB HIGMAN 01JAN2012 CHK T. ELBIN 01JAN2012 APVD T. ELBIN 01JAN2012	TE Connectivity Harrisburg, PA 17105-3608
DIMENSIONS: mm TOLERANCES UNLESS OTHERWISE SPECIFIED: 0 PLC ± 1 PLC ± 2 PLC ± 3 PLC ± 4 PLC ± ANGLES ± FINISH ±		NAME Ocean Side Feed Applicator PRODUCT SPEC APPLICATION SPEC SIZE CAGE CODE DRAWING NO A1 00779 C=2151739	RESTRICTED TO SCALE 1:2 SHEET 4 OF 4 REV E1
MATERIAL:		WEIGHT:	Customer Accessible Production Drawing