

PART NUMBER	REVISION	DESCRIPTION	FEED TYPE
2150274-2	D	FINE CRIMP HEIGHT ADJUST	PNEUMATIC
7-2150274-2	D	PNEUMATIC AND CRIMP TOOLING KIT	PNEUMATIC
7-2150274-7	D	CRIMP TOOLING KIT	-

ATLANTIC VERSION TERMINATOR INTERFACE ADAPTER

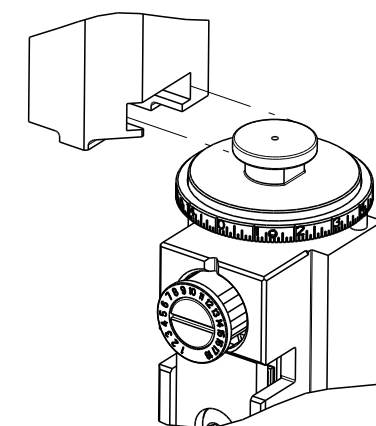

APPLICATOR DATA		
CRIMP	SIZE	TYPE
WIRE	4.50 mm [.177]	F
INSUL	5.55 mm [.219]	OV
APPL INSTRUCTIONS 408-35043		

TERMINAL DATA: G&H (LEAR) TERMINAL LEAR CRIMP SPECIFICATION

TERMINAL NAME: RING TONGUE

WIRE STRIP LENGTH	INSULATION DIAMETER RANGE
6.00-7.00 mm [.236-.276 IN]	Ø3.40-4.30 mm [.134-.169 IN]

TERMINAL APPLICATION SPECIFICATION	25235 Rev 16

TERMINALS APPLIED

TE TERMINAL	6&H (LEAR) TERMINAL	TE TERMINAL	6&H (LEAR) TERMINAL
1572522-1	25235-122.014	1572522-6	25235.123.321
1572522-2	25235.123.014	1572522-7	25235.123.322
1572522-3	25235.122.323	1572522-8	25235.212.179
1572522-4	25235.123.009	1572522-9	25235.213.009
1572522-5	25235.123.011	1-1572522-0	25235.213.011
		1-1572522-1	25235.213.321

WIRE SIZE	CRIMP HEIGHT mm [INCH]	CRIMP HEIGHT REFERENCE SETTING
6.00mm2	3.15 +/- 0.10 [.124 +/- .004]	5.9
4.00mm2	2.95 +/- 0.10 [.116 +/- .004]	8.1



- 1 RECOMMENDED SPARE PARTS
 - 2 REFER TO SUPPLIED INSTRUCTION SHEET FOR CLEANING, LUBRICATION AND STORAGE OF APPLICATOR.
 - 3 APPLY PART NUMBER 1-23419-5 LOCTITE TO THREADS OF ITEM 50. APPLY PART NUMBER 2-23419-6 LOCTITE TO THREADS OF ITEM 242.
 - 4 CRIMP HEIGHT REFERENCE SETTING WAS THE SETTING USED WHEN THE APPLICATOR WAS QUALIFIED AT THE FACTORY. ADJUSTMENT MAY BE NECESSARY WHEN RUNNING APPLICATOR IN THE FIELD.
 - 5 TERMINAL PITCH NOT COMPATIBLE WITH MECHANICAL FEED.
 - 6 TERMINAL LUBRICANT IS RECOMMENDED.
7. UNLESS SPECIFIED OTHERWISE TORQUE VALUES SHALL BE USED PER DOCUMENT, 101-35000.

***WARNING**
ON INSTALLATION, SET WIRE DISC TO CRIMP HEIGHT REFERENCE SETTING FOR LARGEST WIRE SIZE. CRIMP HEIGHT REFERENCE SETTINGS GREATER THAN THE VALUE SHOWN MAY CAUSE DAMAGE TO THE CRIMP TOOLING, REFER TO THE INSTRUCTION SHEET FOR PROPER SETUP AND ADJUSTMENTS.

ATLANTIC VERSION
Shown on sheets 1 of 4 & 2 of 4
(Pacific version shown on sheets 3 of 4 & 4 of 4)

LOC	DIST	REVISIONS					
A	66	P	LTN	DESCRIPTION	DATE	OWN	APVD
		A		RELEASED	02SEP2016	MR	TE
		B		ECR-21-004087	06APR2021	LG	TE
		C		ECR-21-004087	20APR2021	JWC	RK
		D		ECR-22-138115	05MAY2022	JWC	TE

-	1	1	2119641-1	FEED CAM, AIR FEED	248	
-	1	1	2119082-4	CAM, SNAIL, INSULATION ADJUSTMENT	244	
-	1	1	2079764-1	WASHER, WAVE SPRING, CREST-TO-CREST	243	
3	-	1	1	2119083-1	RETAINER, INSULATION DIAL	242
-	1	1	2844940-4	AIR FEED MODULE	238	
-	1	1	1-18028-0	WASHER, FLAT, REG M8	192	
-	1	1	6-993111-6	PIN, SLOTTED SPRING 3.0 X 14.0	177	
-	1	1	8-22280-7	SPRING, COMPRESSION	176	
-	1	1	1752353-2	GUIDE PIN,HOLDDOWN	175	
-	1	1	1901680-2	GUIDE PIN,HOLDDOWN	174	
-	REF	REF	994970-2	COUNTER, MAGNETIC	164	
6	-	1	1	2119955-2	ASSY, LUBRICATOR, END FEED	84
-	1	1	455888-5	SPACER, CRIMPER	82	
-	1	1	2119791-5	DEPRESSOR, WIRE	73	
-	1	1	1803607-4	DOCUMENTATION PACKAGE	71	
-	2	2	2-18032-2	SCR, SET, FLT PNT, M3 X 10.0	70	
-	1	1	2119943-1	WASHER, SPACER	69	
-	1	1	2119740-1	TAG, IDENTIFICATION	67	
-	2	2	2168078-1	SCREW, DRIVE, RH, RoHS, 2 x .188	66	
-	1	1	1901681-1	HOLDDOWN, TERMINAL	65	
-	1	1	2168083-2	SCR, SKT HD CAP, RoHS, M4 X 8.0	60	
-	1	1	5-18022-5	SCR, HEX HD CAP, M4 X 6.0	59	
-	4	4	2168400-4	SHCS, LOW HEAD, RoHS, M4 X 8	57	
-	2	2	2168083-9	SCR, SKT HD CAP, RoHS, M4 X 20	56	
-	2	2	5018030-1	NUT, HEX, REG, RoHS, M3	54	
-	2	2	986965-8	NUT, LOCK, HEX, TORQUE (M4)	53	
-	1	1	1-5018030-0	NUT, HEX, REG, RoHS, M3.5	52	
-	1	1	2063961-1	FEED FINGER	51	
3	-	1	1	1752354-7	STANDOFF,HOLD-DOWN	50
-	1	1	18023-9	SCR, SKT HD CAP M4 X 6.0	49	
-	1	1	2119655-5	APPLICATOR BASIC ASSEMBLY, EF	46	
-	1	1	1803517-1	RAM ASSEMBLY, EF ATLANTIC	44	
-	1	1	1803602-1	SCR, BHSC, RoHS (M8 X 25)	41	
-	8	8	1-18028-2	WASHER, FLAT, REG M4	33	
-	2	2	2168083-9	SCR, SKT HD CAP, RoHS, M4 X 20	31	
-	2	2	2168083-2	SCR, SKT HD CAP, RoHS, M4 X 8.0	29	
-	1	1	690455-9	STRIPPER, FRONT CASTING	27	
-	2	2	1-2168083-5	SCR, SKT HD CAP, RoHS, M4 X 30	25	
-	1	1	1752371-5	PLATE, STRIP GUIDE	24	
-	2	2	2-22281-3	SPRING, COMPRESSION	22	
-	1	1	1803292-1	DRAG	20	
-	1	1	4-1901696-6	STRIP GUIDE, REAR	19	
-	1	1	4-1901695-6	STRIP GUIDE, FRONT	18	
-	4	4	1-2079383-1	SCR, BHSC, RoHS (M6 X 12)	17	
-	1	1	4-240641-5	SPACER	16	
-	1	1	1752360-1	SPACER,HOLD-DOWN	13	
1	-	1	1	240644-1	PLATE, REAR SHEAR	11
-	-	-	-	-	10	
1	-	1	1	690482-4	PLATE, FRONT SHEAR	9
1	1	2	1	5-1803059-2	ANVIL, COMBINATION, END FEED	8
1	-	1	1	1-2217206-2	BLADE, SLUG	7
-	1	1	1	7-240641-5	SPACER	5
-	1	1	1	238011-3	BLOCK, CRIMPER SPACER	4
1	1	2	1	2-1633964-5	CRIMPER, INSULATION OVERLAP PREMIUM	3
-	1	1	1	1-455888-2	SPACER, CRIMPER	2
1	1	2	1	7-1673600-7	CRIMPER, WIRE	1
-	77	72	-2	PART NO	DESCRIPTION	ITEM NO

DIMENSIONS:		TOLERANCES UNLESS OTHERWISE SPECIFIED:		DRAWING NO	
mm	0 PLC ±	1 PLC ±	2 PLC ±	3 PLC ±	4 PLC ±
	ANGLES	FINISH			
MATERIAL		FINISH		WEIGHT	
				A1 00779 C=2150274	
CUSTOMER ACCESSIBLE PRODUCTION DRAWING		SCALE 1:1		SHEET 1 OF 4 REV D	

LOC		DIST		REVISIONS			
A	66	P	LTM	DESCRIPTION	DATE	OWN	APVD
		-		SEE SHEET 1			

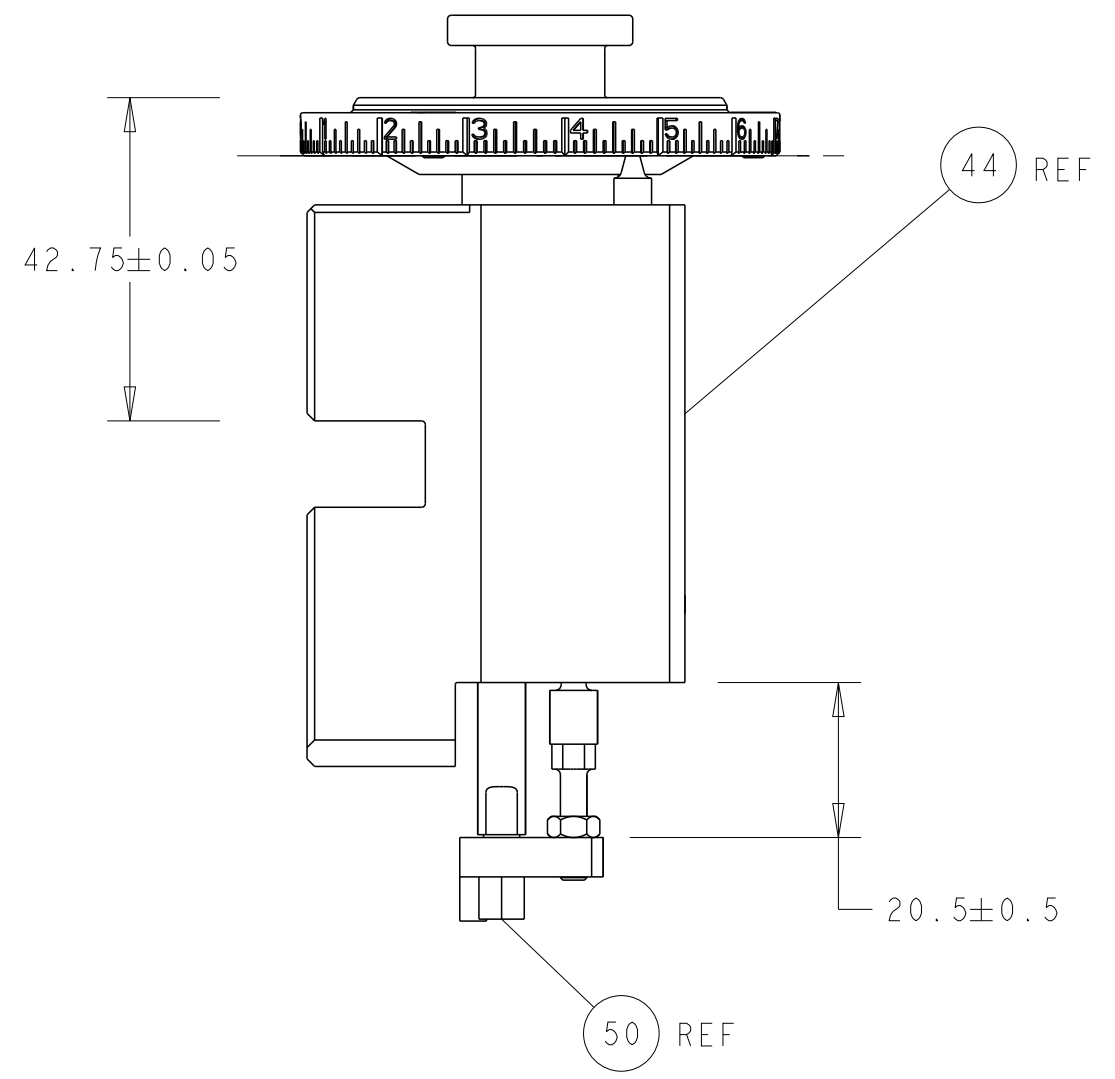

RAM AND HOLDDOWN SET-UP

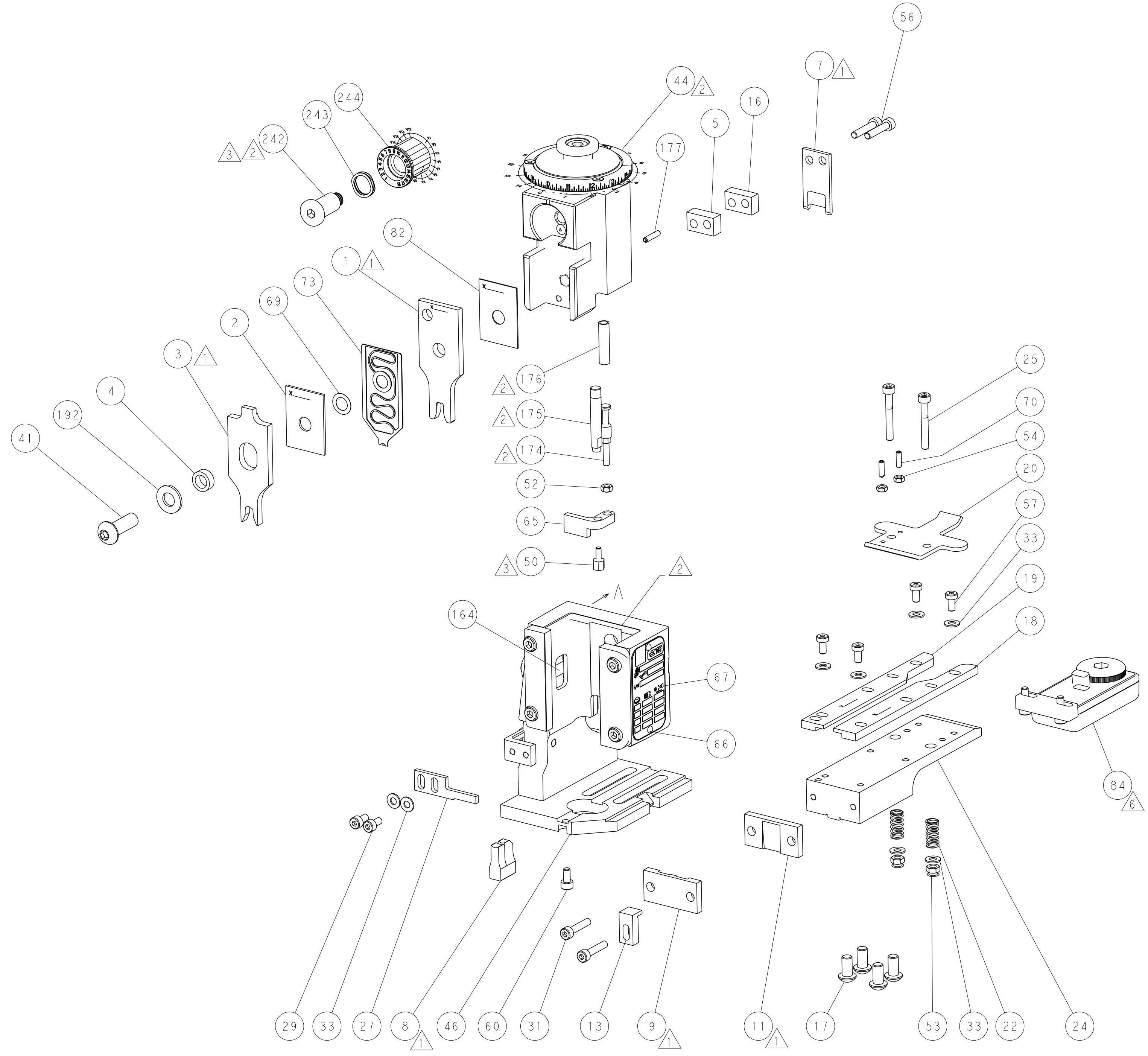
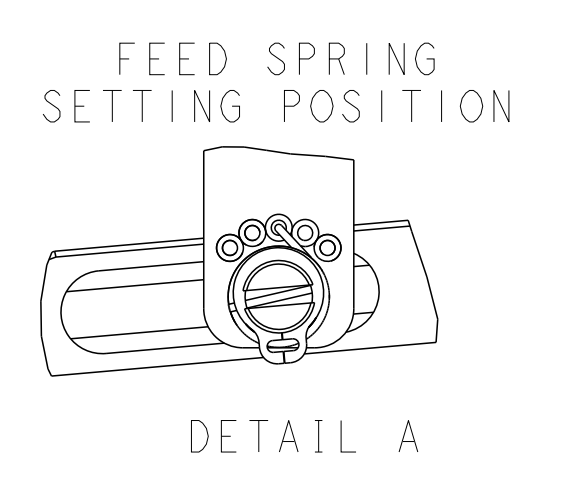
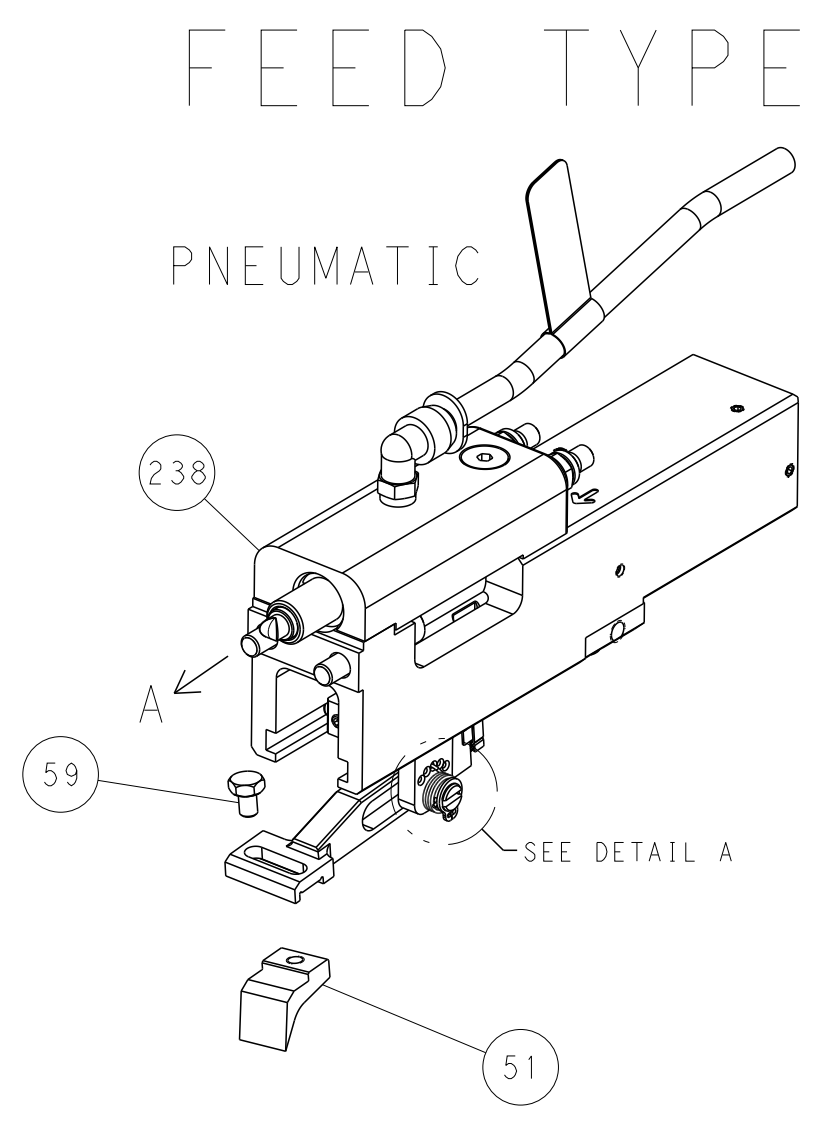

CAM POSITION

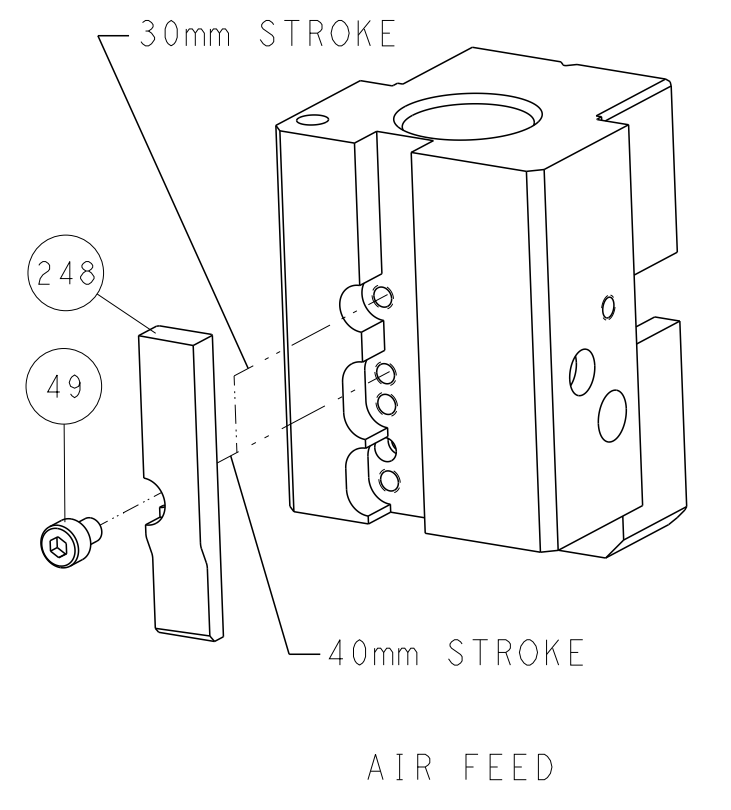

AIR FEED

ATLANTIC VERSION
 Shown on sheets 1 of 4 & 2 of 4
 (Pacific version shown on sheets 3 of 4 & 4 of 4)

<small>THIS DRAWING IS UNPUBLISHED. RELEASED FOR PUBLICATION BY TYCO ELECTRONICS CORPORATION. ALL RIGHTS RESERVED.</small> <small>IT IS THE BUYER'S RESPONSIBILITY TO CONTACT THE SUPPLIER FOR THE LATEST REVISIONS AND TO CONTACT THE SUPPLIER FOR THE LATEST REVISIONS.</small>		DWN L. ZHANG 25JUL2012 CHK L. ZHANG 25JUL2012 S. XI 25JUL2012 APVD S. XI 25JUL2012	TE Connectivity Harrisburg, PA 17105-3608
DIMENSIONS: mm TOLERANCES UNLESS OTHERWISE SPECIFIED: 0 PLC ± 1 PLC ± 2 PLC ± 3 PLC ± 4 PLC ± ANGLES ± MATERIAL - FINISH -		NAME Ocean End Feed Applicator PRODUCT SPEC - APPLICATION SPEC - WEIGHT - SCALE 1:1	SIZE CAGE CODE DRAWING NO RESTRICTED TO A1 00779 C=2150274 SHEET 2 OF 4 REV D
CUSTOMER ACCESSIBLE PRODUCTION DRAWING			

PART NUMBER	REVISION	DESCRIPTION	FEED TYPE
2-2150274-2	D	FINE CRIMP HEIGHT ADJUST	PNEUMATIC
7-2150274-7	D	CRIMP TOOLING KIT	-

PACIFIC VERSION TERMINATOR
 INTERFACE ADAPTER

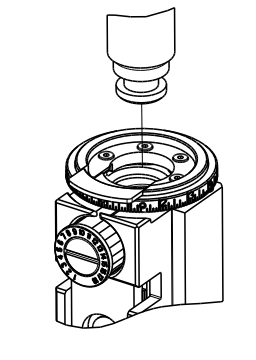

APPLICATOR DATA		
CRIMP	SIZE	TYPE
WIRE	4.50 mm [.177]	F
INSUL	5.55 mm [.219]	OV
APPL INSTRUCTIONS 408-35043		

TERMINAL DATA: G&H (LEAR) TERMINAL LEAR CRIMP SPECIFICATION

TERMINAL NAME: RING TONGUE	
WIRE STRIP LENGTH 6.00-7.00 mm [.236-.276 IN]	INSULATION DIAMETER RANGE Ø3.40-4.30 mm [.134-.169 IN]
TERMINAL APPLICATION SPECIFICATION 25235 Rev 16	

TE TERMINAL	G&H (LEAR) TERMINAL	TE TERMINAL	G&H (LEAR) TERMINAL
1572522-1	25235-122.014	1572522-6	25235.123.321
1572522-2	25235.123.014	1572522-7	25235.123.322
1572522-3	25235.122.323	1572522-8	25235.212.179
1572522-4	25235.123.009	1572522-9	25235.213.009
1572522-5	25235.123.011	1-1572522-0	25235.213.011
		1-1572522-1	25235.213.321

WIRE SIZE	CRIMP HEIGHT mm [INCH]	CRIMP HEIGHT REFERENCE SETTING
6.00mm2	3.15+/-0.10 [.124+/- .004]	5.9
4.00mm2	2.95+/-0.10 [.116+/- .004]	8.1



- 1. RECOMMENDED SPARE PARTS
- 2. REFER TO SUPPLIED INSTRUCTION SHEET FOR CLEANING, LUBRICATION AND STORAGE OF APPLICATOR.
- 3. APPLY PART NUMBER 1-23419-5 LOCTITE TO THREADS OF ITEM 50. APPLY PART NUMBER 2-23419-6 LOCTITE TO THREADS OF ITEM 242.
- 4. CRIMP HEIGHT REFERENCE SETTING WAS THE SETTING USED WHEN THE APPLICATOR WAS QUALIFIED AT THE FACTORY. ADJUSTMENT MAY BE NECESSARY WHEN RUNNING APPLICATOR IN THE FIELD.
- 5. TERMINAL PITCH NOT COMPATIBLE WITH MECHANICAL FEED.
- 6. TERMINAL LUBRICANT IS RECOMMENDED.
- 7. UNLESS SPECIFIED OTHERWISE TORQUE VALUES SHALL BE USED PER DOCUMENT, 101-35000.

***WARNING**
 ON INSTALLATION, SET WIRE DISC TO CRIMP HEIGHT REFERENCE SETTING FOR LARGEST WIRE SIZE. CRIMP HEIGHT REFERENCE SETTINGS GREATER THAN THE VALUE SHOWN MAY CAUSE DAMAGE TO THE CRIMP TOOLING, REFER TO THE INSTRUCTION SHEET FOR PROPER SETUP AND ADJUSTMENTS.

PACIFIC VERSION
 Shown on sheets 3 of 4 & 4 of 4
 (Atlantic version shown on sheets 1 of 4 & 2 of 4)

LOC	DIST	REVISIONS					
A	66	P	LTN	DESCRIPTION	DATE	OWN	APVD
-	-	-	-	SEE SHEET 1	-	-	-

-	1	2119082-4	CAM, SNAIL, INSULATION ADJUSTMENT	244
-	1	2079764-1	WASHER, WAVE SPRING, CREST-TO-CREST	243
-	1	2119083-1	RETAINER, INSULATION DIAL	242
-	1	2844940-4	AIR FEED MODULE	238
-	1	1-18028-0	WASHER, FLAT, REG M8	192
-	4	2079383-9	SCR, BHSC, RoHS (M6 X 20)	186
-	1	6-993111-6	PIN, SLOTTED SPRING 3.0 X 14.0	177
-	1	8-22280-7	SPRING, COMPRESSION	176
-	1	1752353-2	GUIDE PIN,HOLDDOWN	175
-	1	1901680-2	GUIDE PIN,HOLDDOWN	174
-	REF	994970-2	COUNTER, MAGNETIC	164
-	1	2119641-2	FEED CAM, AIR FEED	152
-	1	2168083-8	SCR, SKT HD CAP, RoHS, M4 X 16	144
-	1	2119655-6	APPLICATOR BASIC ASSEMBLY, EF	141
-	1	1803518-1	RAM ASSEMBLY, EF PACIFIC	140
-	1	2119955-2	ASSY, LUBRICATOR, END FEED	84
-	1	455888-5	SPACER, CRIMPER	82
-	1	2119791-5	DEPRESSOR, WIRE	73
-	1	1803607-4	DOCUMENTATION PACKAGE	71
-	2	2-18032-2	SCR, SET, FLT PNT, M3 X 10.0	70
-	1	2119943-1	WASHER, SPACER	69
-	1	2119740-1	TAG, IDENTIFICATION	67
-	2	2168078-1	SCREW, DRIVE, RH, RoHS, 2 x .188	66
-	1	1901681-1	HOLDDOWN, TERMINAL	65
-	1	5-18022-5	SCR, HEX HD CAP, M4 X 6.0	59
-	4	2168400-4	SHCS, LOW HEAD, RoHS, M4 X 8	57
-	2	2168083-9	SCR, SKT HD CAP, RoHS, M4 X 20	56
-	2	5018030-1	NUT, HEX, REG, RoHS, M3	54
-	2	986965-8	NUT, LOCK, HEX, TORQUE (M4)	53
-	1	1-5018030-0	NUT, HEX, REG, RoHS, M3.5	52
-	1	2063961-1	FEED FINGER	51
-	1	1752354-7	STANDOFF, HOLD-DOWN	50
-	1	18023-9	SCR, SKT HD CAP M4 X 6.0	49
-	1	1803602-1	SCR, BHSC, RoHS (M8 X 25)	41
-	8	1-18028-2	WASHER, FLAT, REG M4	33
-	2	2168083-9	SCR, SKT HD CAP, RoHS, M4 X 20	31
-	2	2168083-2	SCR, SKT HD CAP, RoHS, M4 X 8.0	29
-	1	690455-9	STRIPPER, FRONT CASTING	27
-	2	1-2168083-5	SCR, SKT HD CAP, RoHS, M4 X 30	25
-	1	1752371-5	PLATE, STRIP GUIDE	24
-	2	2-22281-3	SPRING, COMPRESSION	22
-	1	1803292-1	DRAG	20
-	1	4-1901696-6	STRIP GUIDE, REAR	19
-	1	4-1901695-6	STRIP GUIDE, FRONT	18
-	1	4-240641-5	SPACER	16
-	1	1752360-1	SPACER,HOLD-DOWN	13
-	1	240644-1	PLATE, REAR SHEAR	11
-	-	-	-	10
-	1	690482-4	PLATE, FRONT SHEAR	9
1	1	5-1803059-2	ANVIL, COMBINATION, END FEED	8
-	1	1-2217206-2	BLADE, SLUG	7
-	1	7-240641-5	SPACER	5
-	1	238011-3	BLOCK, CRIMPER SPACER	4
1	1	2-1633964-5	CRIMPER, INSULATION OVERLAP PREMIUM	3
-	1	1-455888-2	SPACER, CRIMPER	2
1	1	7-1673600-7	CRIMPER, WIRE	1

DIMENSIONS:		TOLERANCES UNLESS OTHERWISE SPECIFIED:		DATE		NAME	
mm	0 PLC ±	1 PLC ±	2 PLC ±	25 JUL 2012	CHK	L. ZHANG	25 JUL 2012
	3 PLC ±	4 PLC ±	ANGLES ±	25 JUL 2012	CHK	L. ZHANG	25 JUL 2012
	FINISH				APVD	S. XI	25 JUL 2012
MATERIAL					PRODUCT SPEC		
					APPLICATION SPEC		
					WEIGHT		
					SIZE	CAGE CODE	DRAWING NO
					A1	00779	2150274
					CUSTOMER ACCESSIBLE PRODUCTION DRAWING	SCALE	1:1 SHEET 3 OF 4 REV D

LOC	DIST	REV	DATE	BY	APPV
A	66				

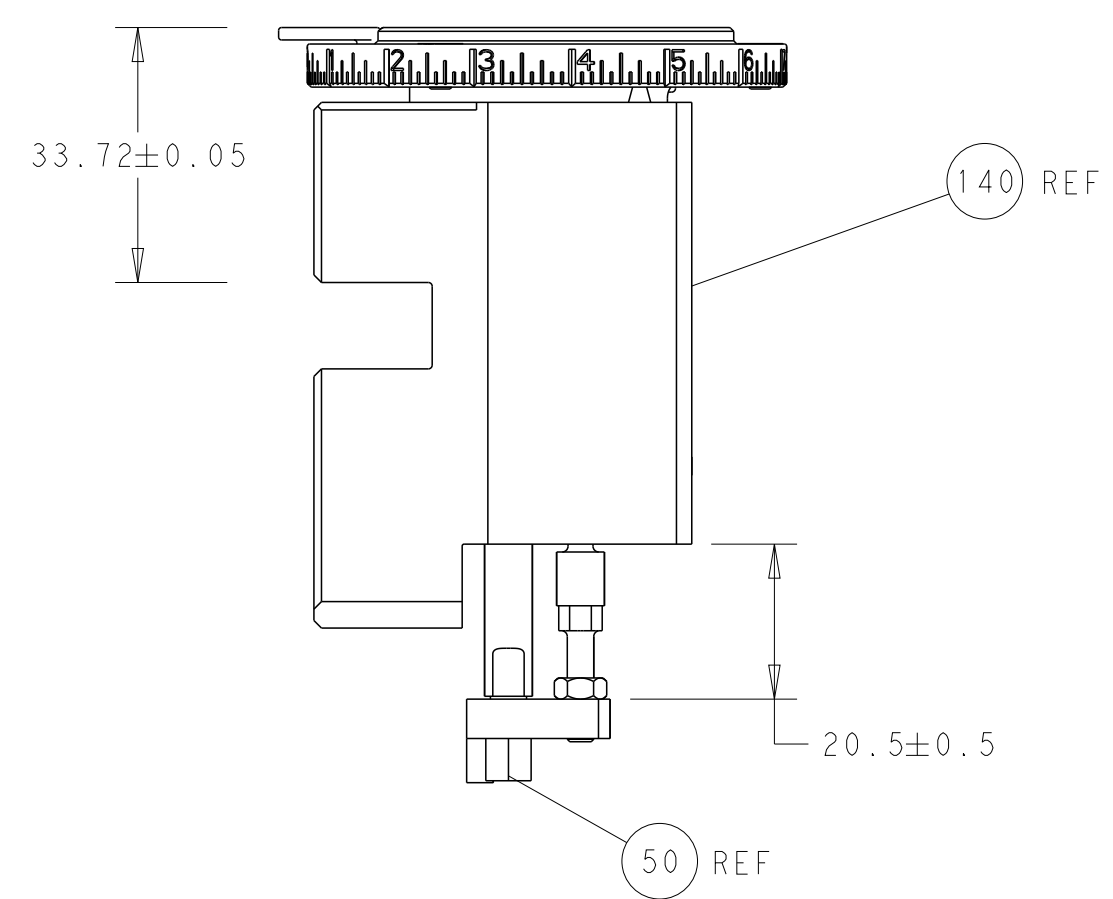

RAM AND HOLDDOWN SET-UP

FEED TYPE

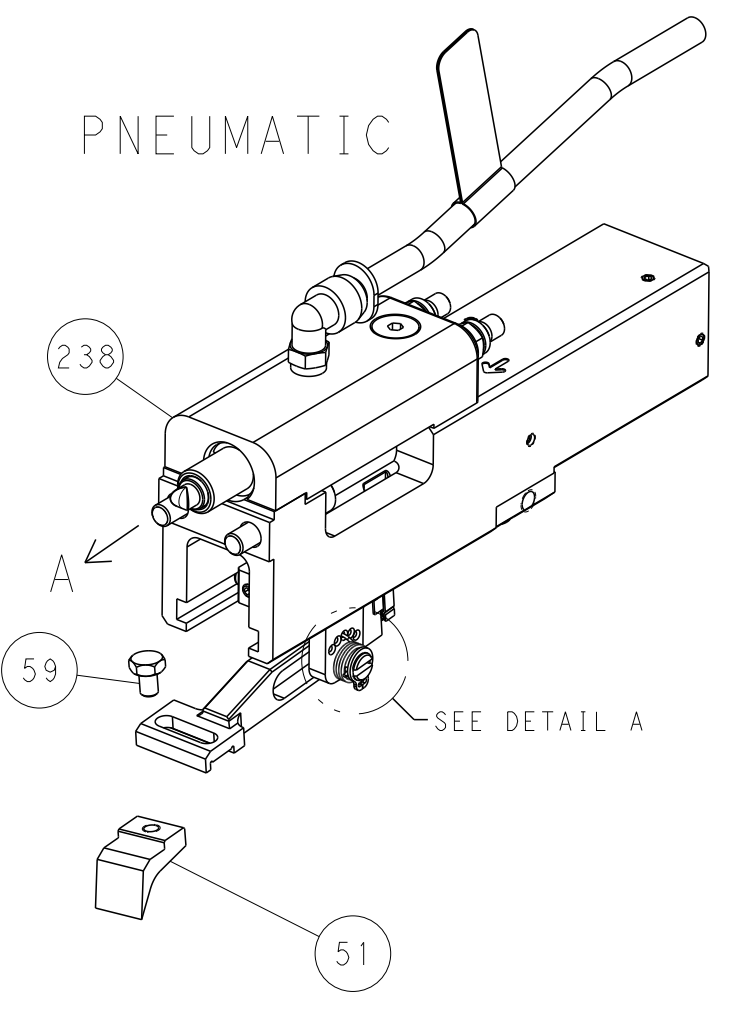

FEED SPRING SETTING POSITION

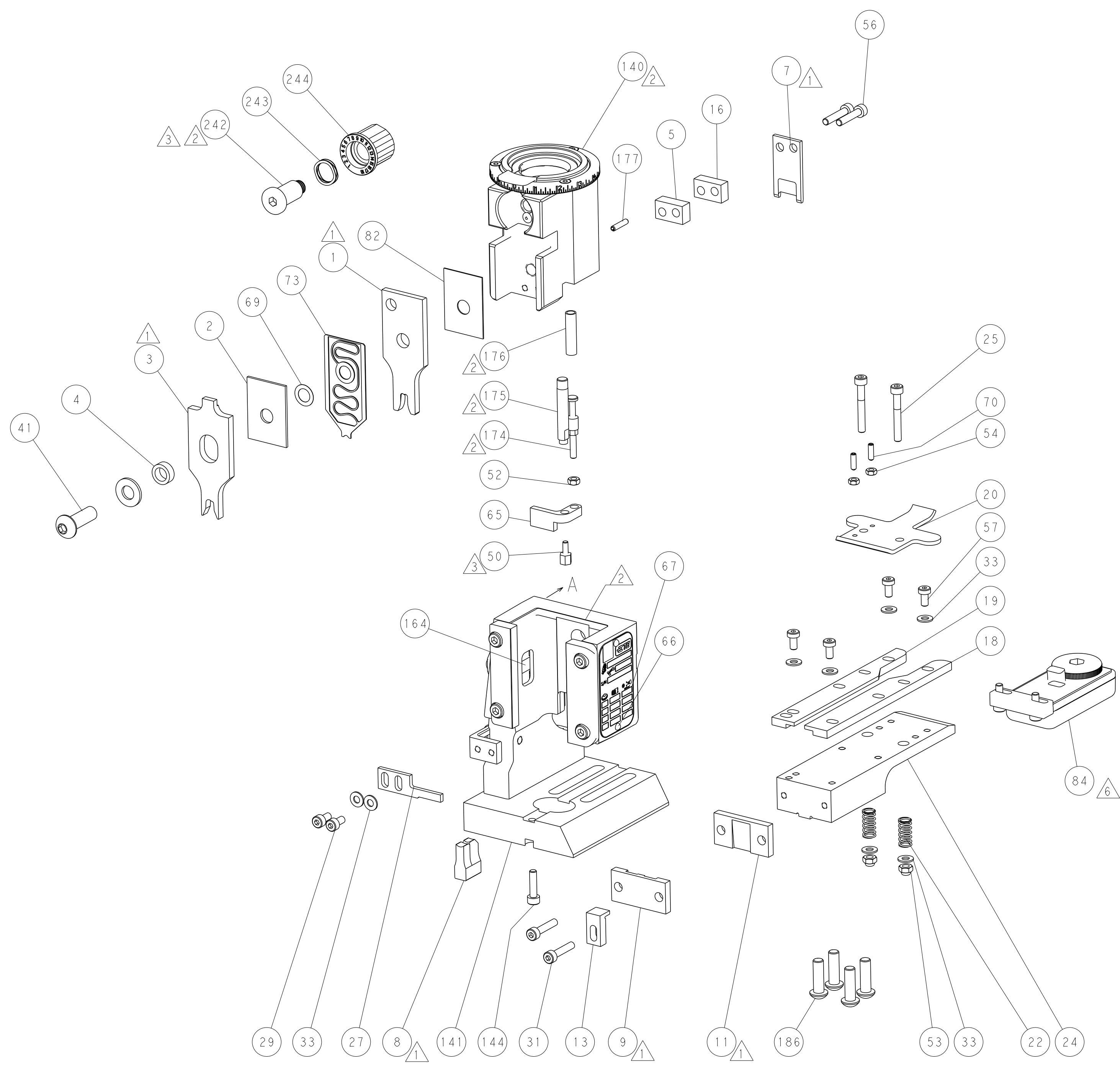
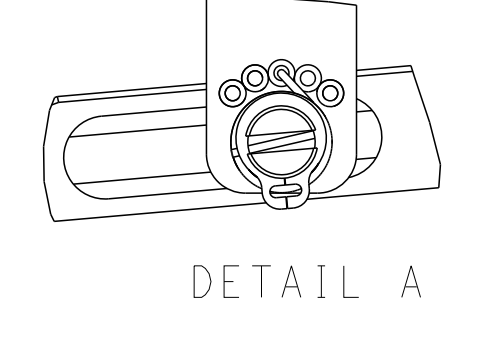

CAM POSITION

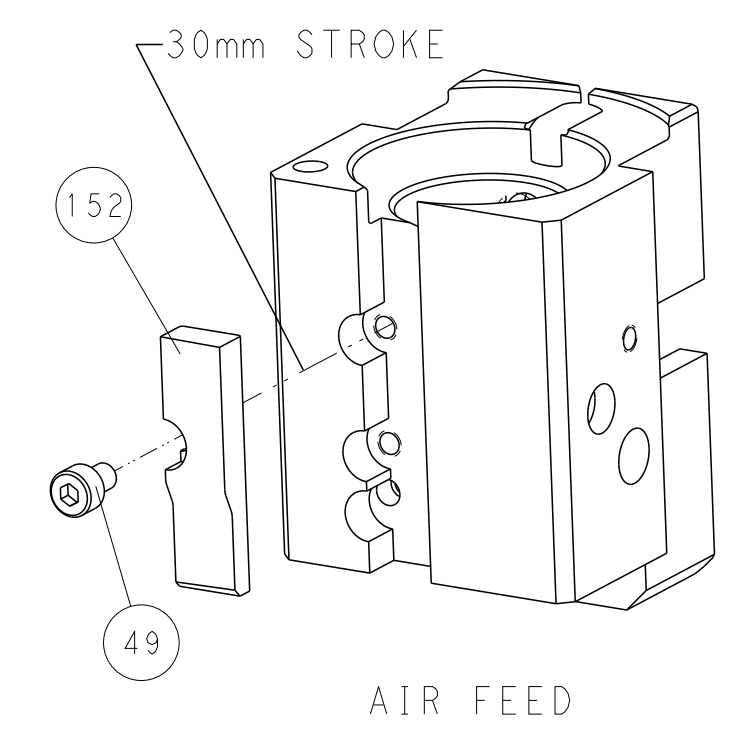

AIR FEED

PACIFIC VERSION
 Shown on sheets 3 of 4 & 4 of 4
 (Atlantic version shown on sheets 1 of 4 & 2 of 4)

DIMENSIONS: mm 		TOLERANCES UNLESS OTHERWISE SPECIFIED: 0 PLC ± 1 PLC ± 2 PLC ± 3 PLC ± 4 PLC ± ANGLES ± FINISH		DWN L. ZHANG 25JUL2012 CHK L. ZHANG 25JUL2012 S. XI 25JUL2012 NAME PRODUCT SPEC APPLICATION SPEC WEIGHT CUSTOMER ACCESSIBLE PRODUCTION DRAWING		STE TE Connectivity Harrisburg, PA 17105-3608 NAME Ocean End Feed Applicator SIZE CAGE CODE DRAWING NO A1 00779 C=2150274 SCALE 1:1 SHEET 4 OF 4 REV D	
-----------------------	--	---	--	---	--	---	--