

4

3

2

1

RELEASED FOR PUBLICATION  
ALL RIGHTS RESERVED.

Project NR  
PRJ-16-000908122

REVISIONS

P	LTR	DESCRIPTION	DATE	DWN	APVD
	A	Disptaching 332490	17NOV2017	MB	MV

© COPYRIGHT 20 BY

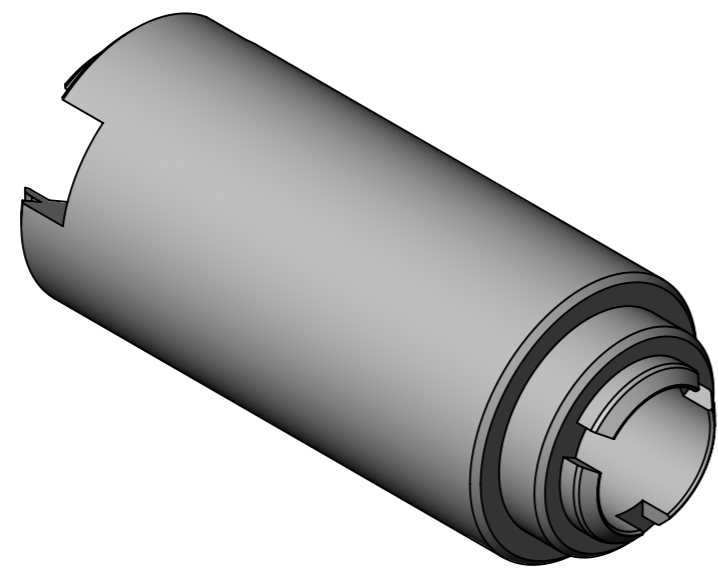

- 1 ( ) : cotes pour information / dimensions for information  
 ( ) : cotes de controle / inspection dimensions

- 2 Customer manual =
- 3 Marquage laser :  
TE + DUTEXT 212751A + Année-semaine  
Laser marking:  
TE + DUTEXT 212751A + Year-week
- 4 Marquage laser / Laser marking :  
FEMALE
- 5 Marquage laser / Laser marking :  
MALE
- 6 Coté de l'outil pour démontage du contact femelle  
Side of the tool for disassembly of the female contact
- 7 Coté de l'outil pour démontage du contact mâle  
Side of the tool for disassembly of the male contact

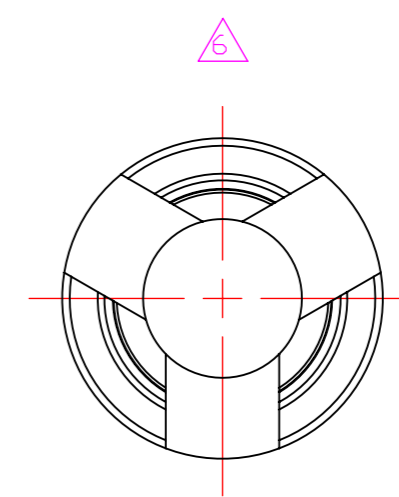
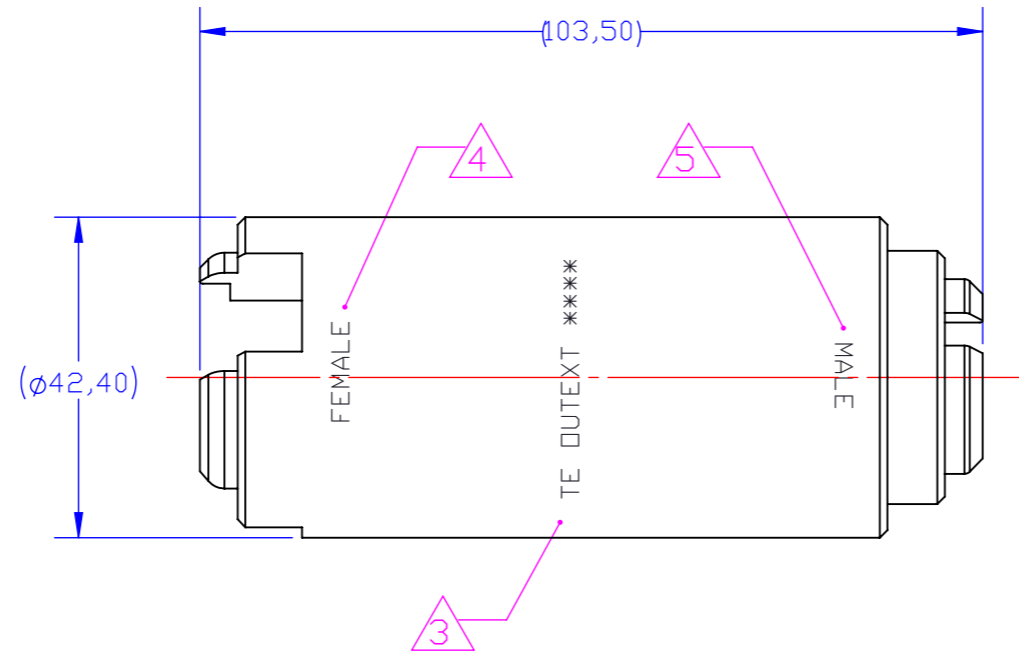
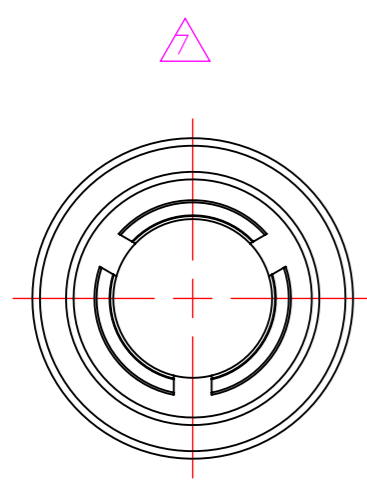

Référence commerciale / Commercial reference : DUTEXT 212751A

YZ-KC-212751A-PY00  
PART NO

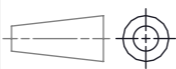
THIS DRAWING IS A CONTROLLED DOCUMENT.		DWN M.BONNIN 17NOV2017	 TE Connectivity				
DIMENSIONS: mm		CHK JF.GALIPAUD 17NOV2017					
TOLERANCES UNLESS OTHERWISE SPECIFIED:		APVD M.VIMARD 17NOV2017	NAME Outil de démontage Dismounting tool				
		PRODUCT SPEC -	APPLICATION SPEC 114-157007				
MATERIAL		FINISH	WEIGHT 129.28 g	SIZE A3	CAGE CODE -	DRAWING NO C-212751	RESTRICTED TO -
-		-	CUSTOMER DRAWING	SCALE 1:1	SHEET 1 OF 1	REV A	