

LOC		DIST		REVISIONS			
GP	00	P	LTR	DESCRIPTION	DATE	DWN	APVD
		A		RELEASED PER ECO-10-025263	16FEB2011	CJV	JTL

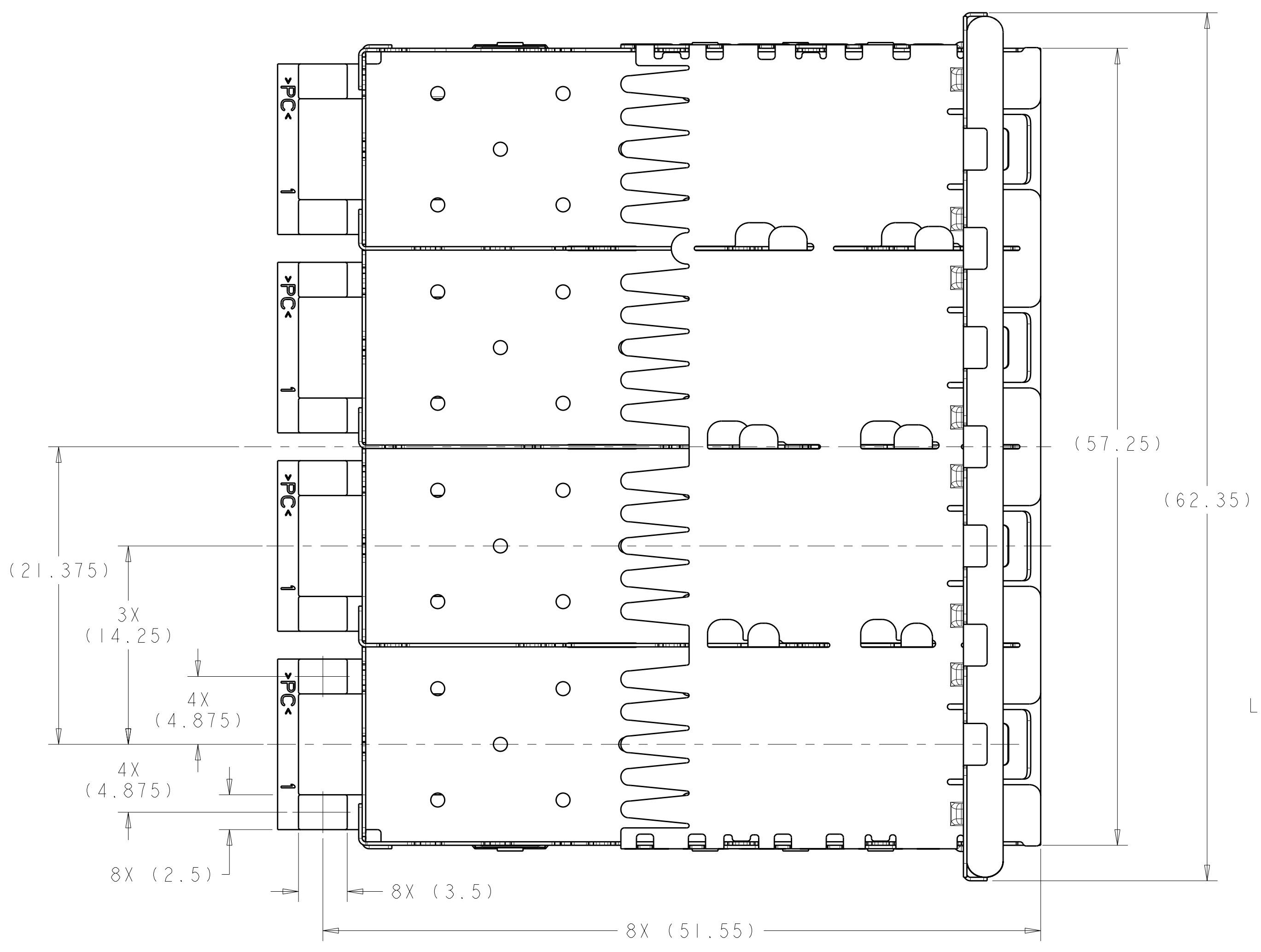

- 1 MATERIAL:  
 CAGE ASSEMBLY: NiAg ALLOY  
 GASKET RETENTION PLATE: STAINLESS STEEL  
 EMI GASKET: PLATED FILLED SILICONE  
 LIGHT PIPE BRACKET: STAINLESS STEEL  
 LIGHT PIPE: POLYCARBONATE, CLEAR
- 2 LIGHT PIPE ASSEMBLY SHIPPED UNASSEMBLED TO CAGE ASSEMBLY. CAGE ASSEMBLY TO BE PRESSED INTO THE PCB PRIOR TO ATTACHING THE LIGHT PIPE ASSEMBLY TO THE CAGE.
- 3 PADS AND VIAS CHASSIS GROUND.
- 4 DATUM AND BASIC DIMENSION ESTABLISHED BY CUSTOMER.
- 5. MATES WITH SFP MSA COMPLIANT TRANSCEIVERS.
- 6. INTERPRETATION OF DATUM REFERENCE FRAME IN ACCORDANCE WITH SECT 4.4.1.1 OF ASME Y14.5M-1994.
- 7 REFERENCE APPLICATION SPEC. 114-13120, HOLE A, FOR RECOMMENDED DRILL HOLE DIAMETER AND PLATING THICKNESS.
- 8 REFERENCE APPLICATION SPEC. 114-13120, HOLE B, FOR RECOMMENDED DRILL HOLE DIAMETER AND PLATING THICKNESS.
- 9 HOLE PATTERN REPEATS FOR EACH PORT. SPACING BETWEEN PORTS IS 14.25mm.
- 10 MINIMUM PC BOARD THICKNESS:  
 SINGLE SIDED = 1.45

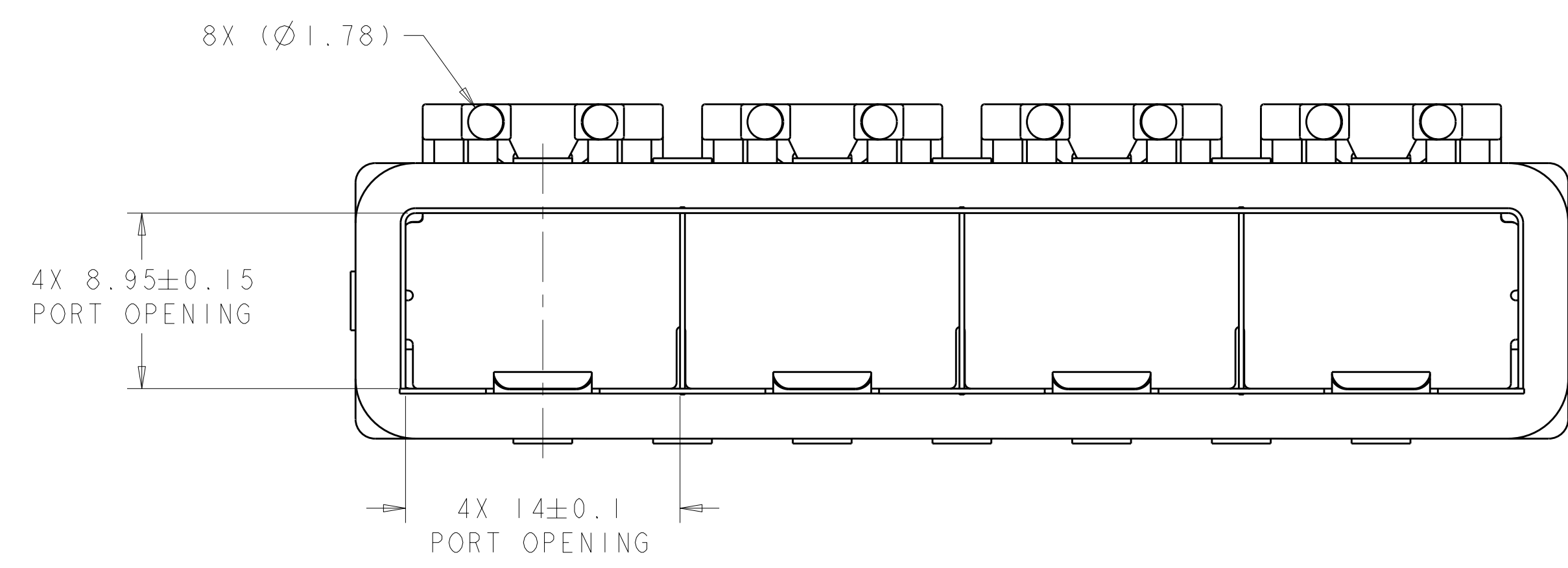
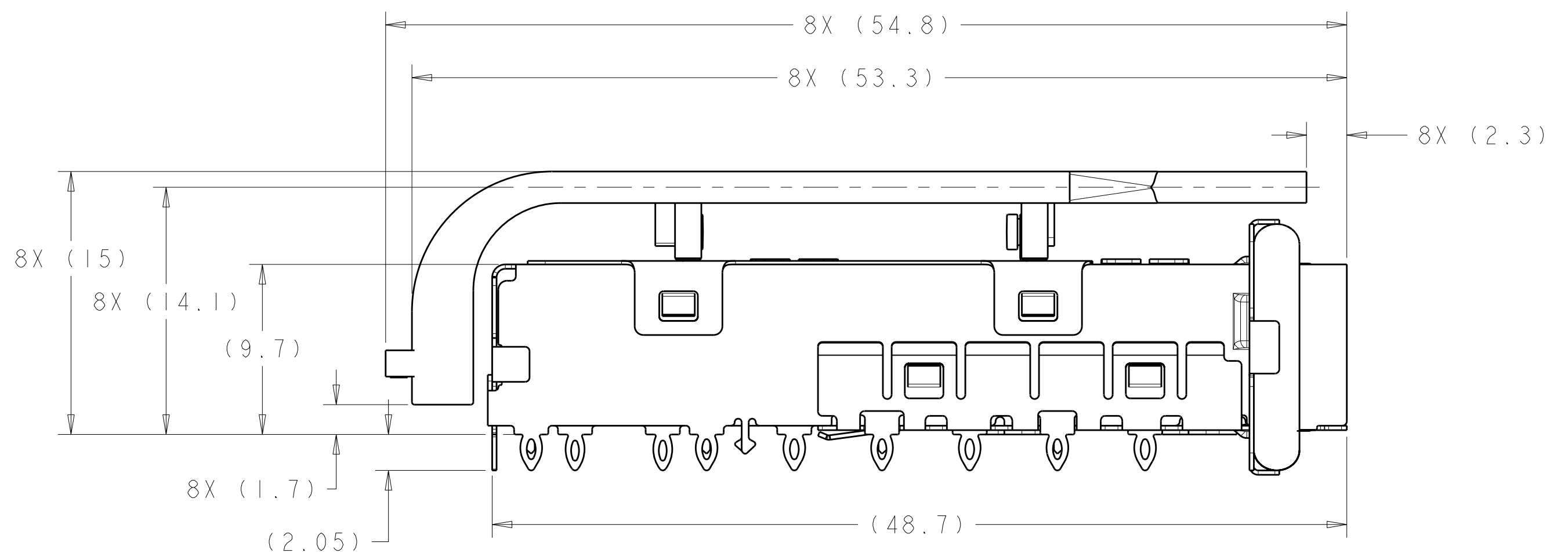
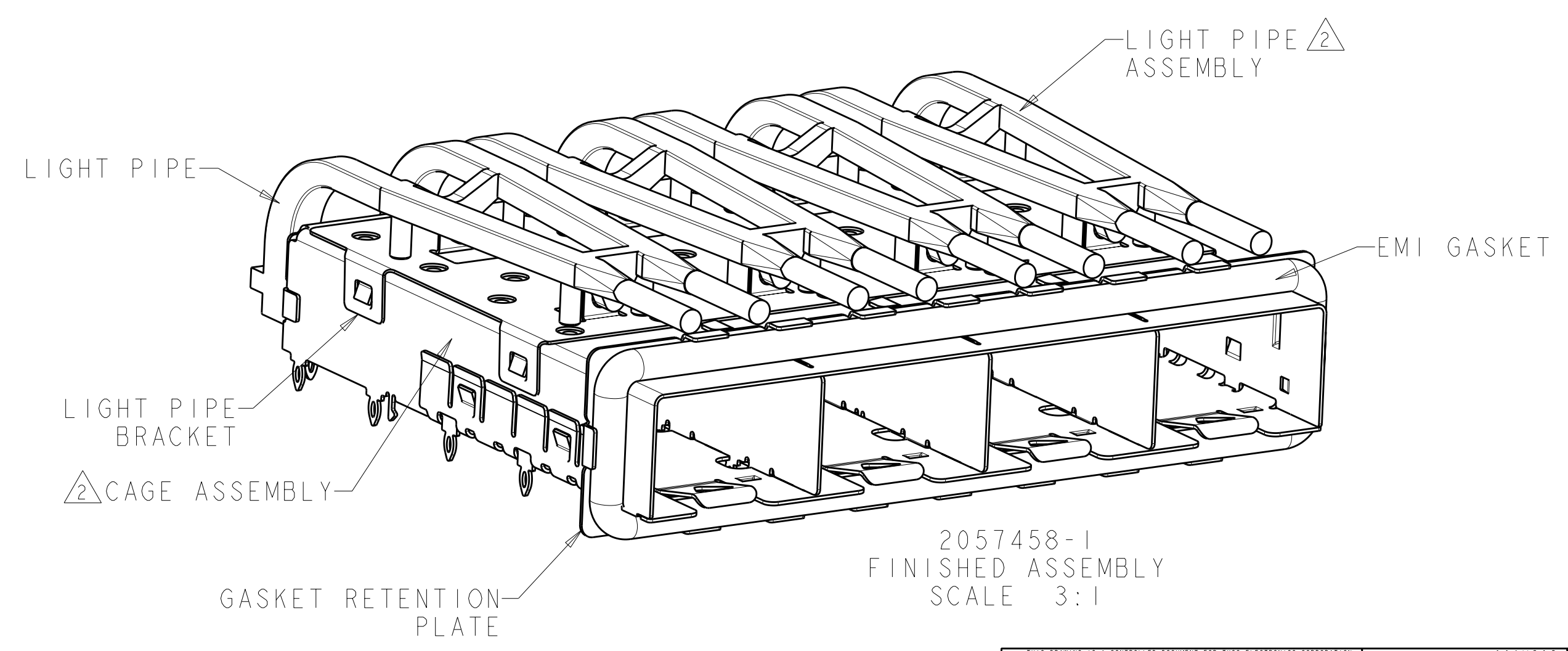

2057458-1  
 FINISHED ASSEMBLY  
 SCALE 3:1

2057458-1  
 PART NUMBER

DIMENSIONS: mm		TOLERANCES UNLESS OTHERWISE SPECIFIED: 9 PLC ±0.1 1 PLC ±0.1 2 PLC ±0.1 3 PLC ±0.1 4 PLC ±0.1 ANGLES ±		DWN: MCMASTER 06AUG08 CHK: M. SCHMITT 06AUG08 APVD: M. SCHMITT 06AUG08		Tyco Electronics Harrisburg, PA 17105-3608	
MATERIAL:		FINISH:		PRODUCT SPEC:		NAME: SFP+ ENHANCED 1X4 CAGE ASSEMBLY PRESS FIT, WITH REDUCED LENGTH LIGHT PIPE	
CUSTOMER DRAWING		WEIGHT:		APPLICATION SPEC: 114-13120		SIZE: CAGE CODE: DRAWING NO: A100779C=2057458	
SCALE: 5:1		SHEET: 1 OF 3		REV: A		RESTRICTED TO:	

LOC	DIST	REV	DESCRIPTION	DATE	DWN	APVD
GP	00		SEE SHEET 1			

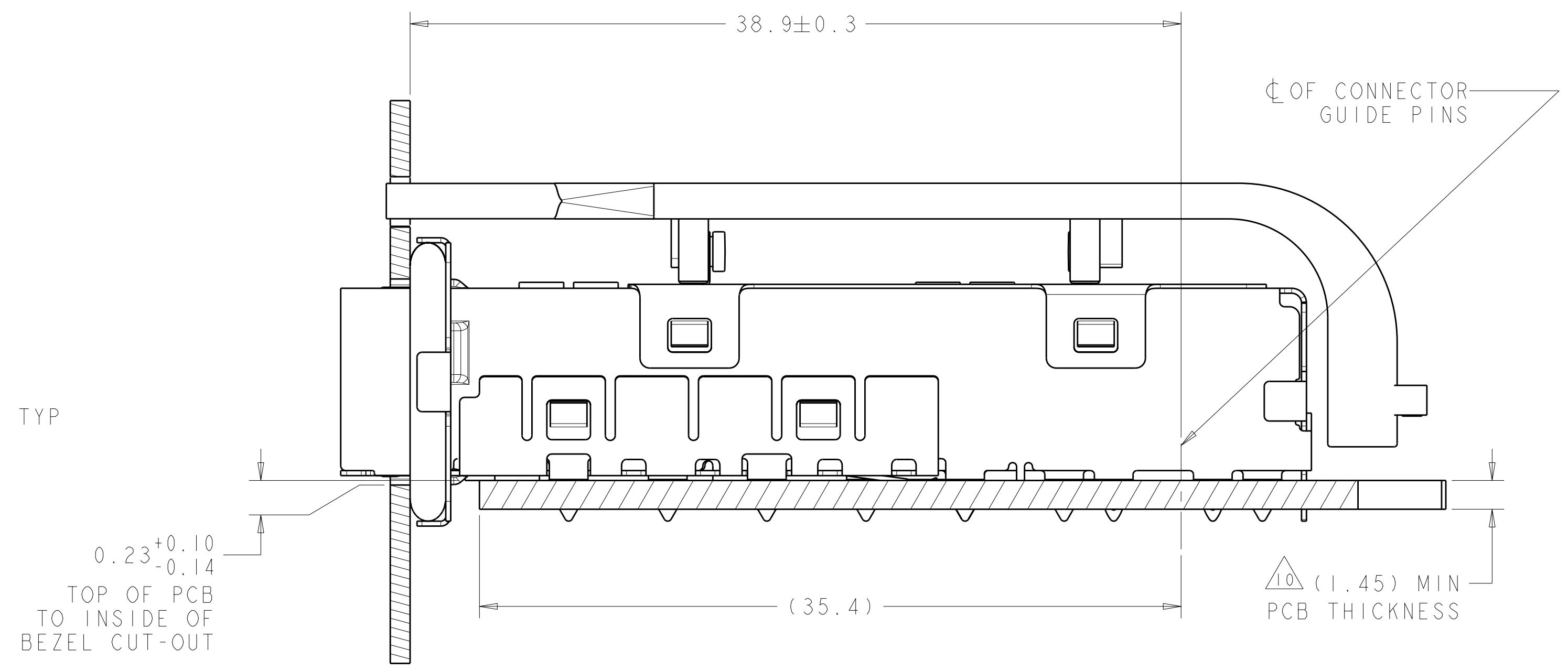
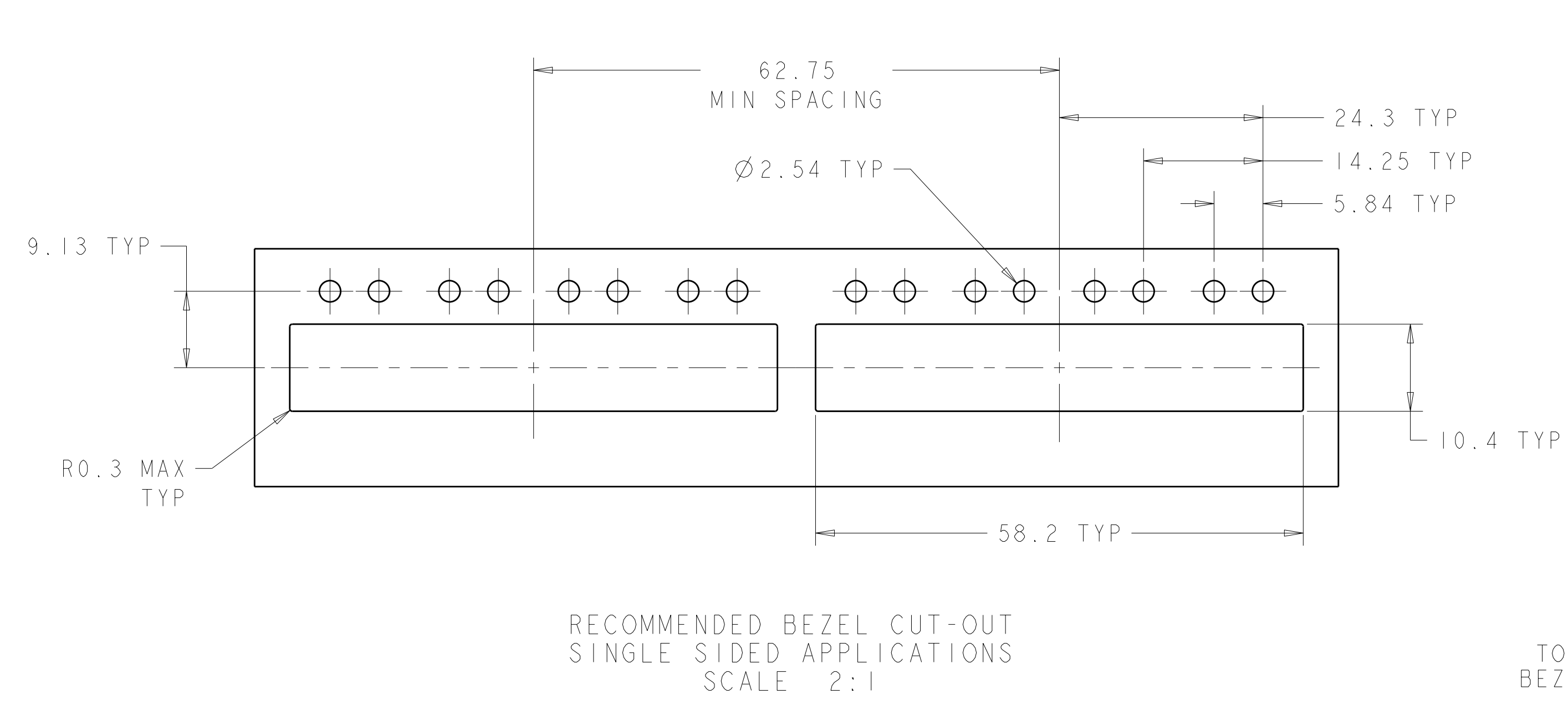

2057458-1  
 MOUNTED ON PC BOARD  
 SHOWN THRU RECOMMENDED BEZEL

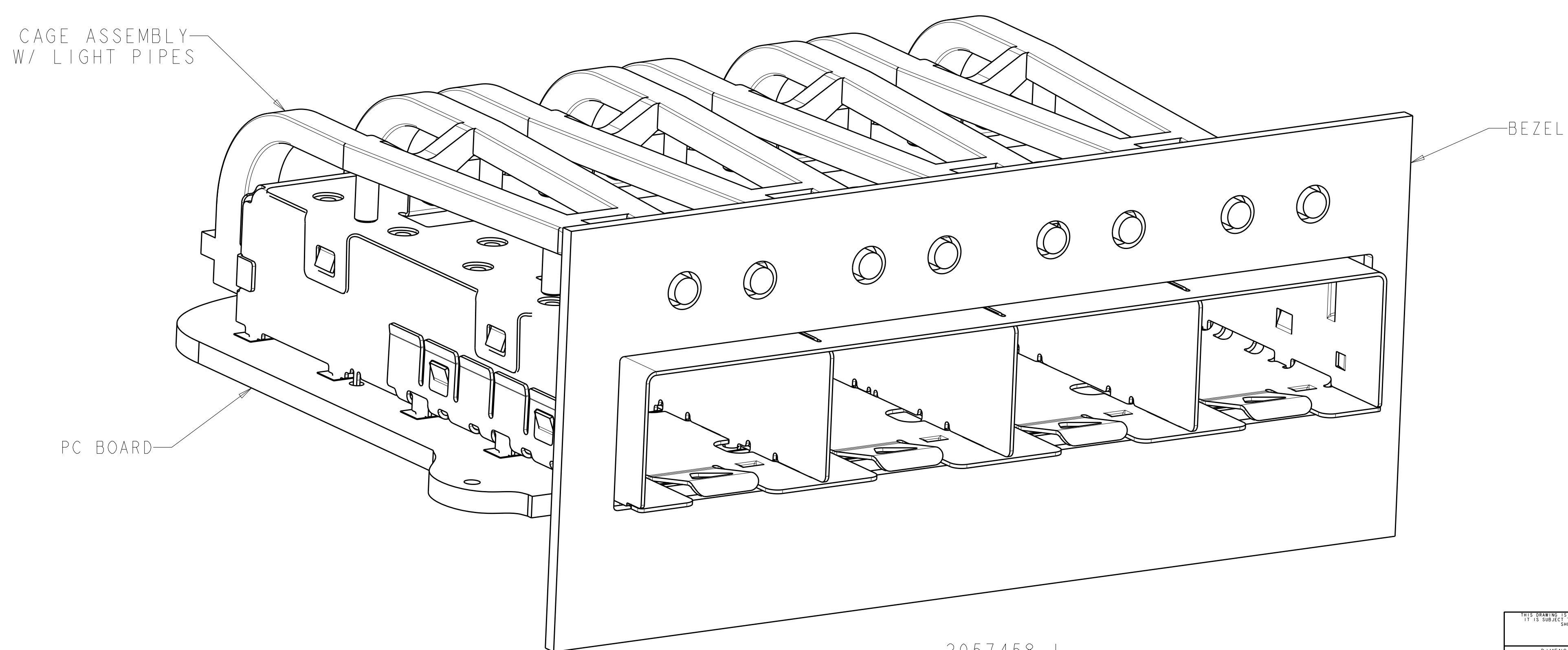

2057458-1  
 MOUNTED ON PCB  
 SHOWN THRU RECOMMENDED BEZEL

<small>THIS DRAWING IS UNPUBLISHED. RELEASED FOR PUBLICATION BY TYCO ELECTRONICS CORPORATION. ALL RIGHTS RESERVED.</small>		DWN: B. MCMASTER 06AUG08 CHK: M. SCHMITT 06AUG08 APVD: M. SCHMITT 06AUG08	Tyco Electronics Harrisburg, PA 17105-3608
DIMENSIONS: mm	TOLERANCES UNLESS OTHERWISE SPECIFIED: 9 PLC ±0.1 1 PLC ±0.1 2 PLC ±0.1 3 PLC ±0.1 4 PLC ±0.1 ANGLES ±1 FINISH -	NAME: SFP+ ENHANCED 1X4 CAGE ASSEMBLY PRODUCT SPEC: - APPLICATION SPEC: - SIZE: 114-13120 WEIGHT: - CUSTOMER DRAWING	Tyco Electronics Harrisburg, PA 17105-3608 NAME: SFP+ ENHANCED 1X4 CAGE ASSEMBLY PRESS FIT, WITH REDUCED LENGTH LIGHT PIPE SIZE: 114-13120 WEIGHT: - CUSTOMER DRAWING
MATERIAL: - FINISH: -		SCALE: 5:1 SHEET: 2 OF 3 REV: A	A100779 ©=2057458

LOC		DIST		REVISONS			
GP	00	P	LTR	DESCRIPTION	DATE	DWN	APVD
		-	-	SEE SHEET 1	-	-	-

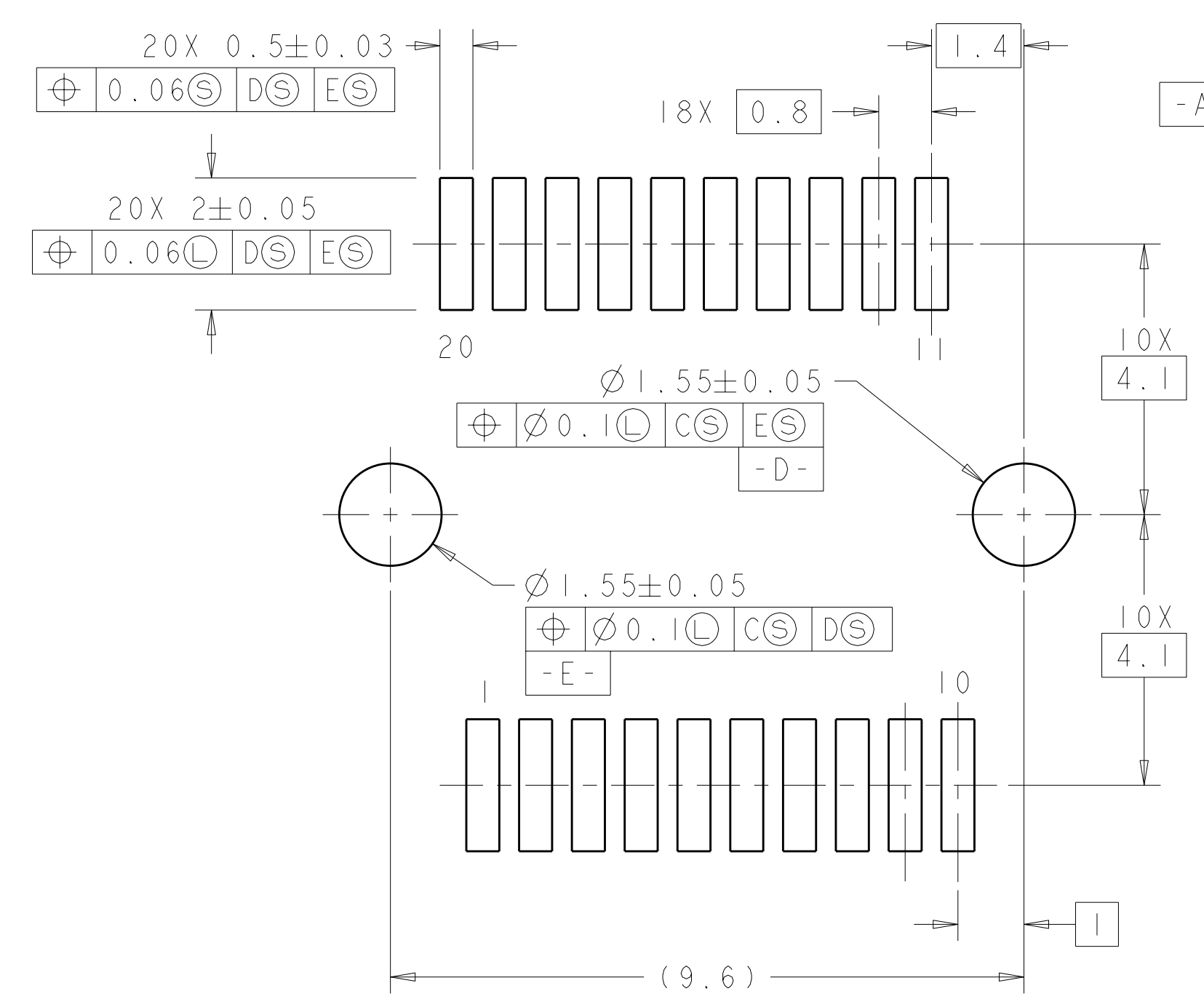
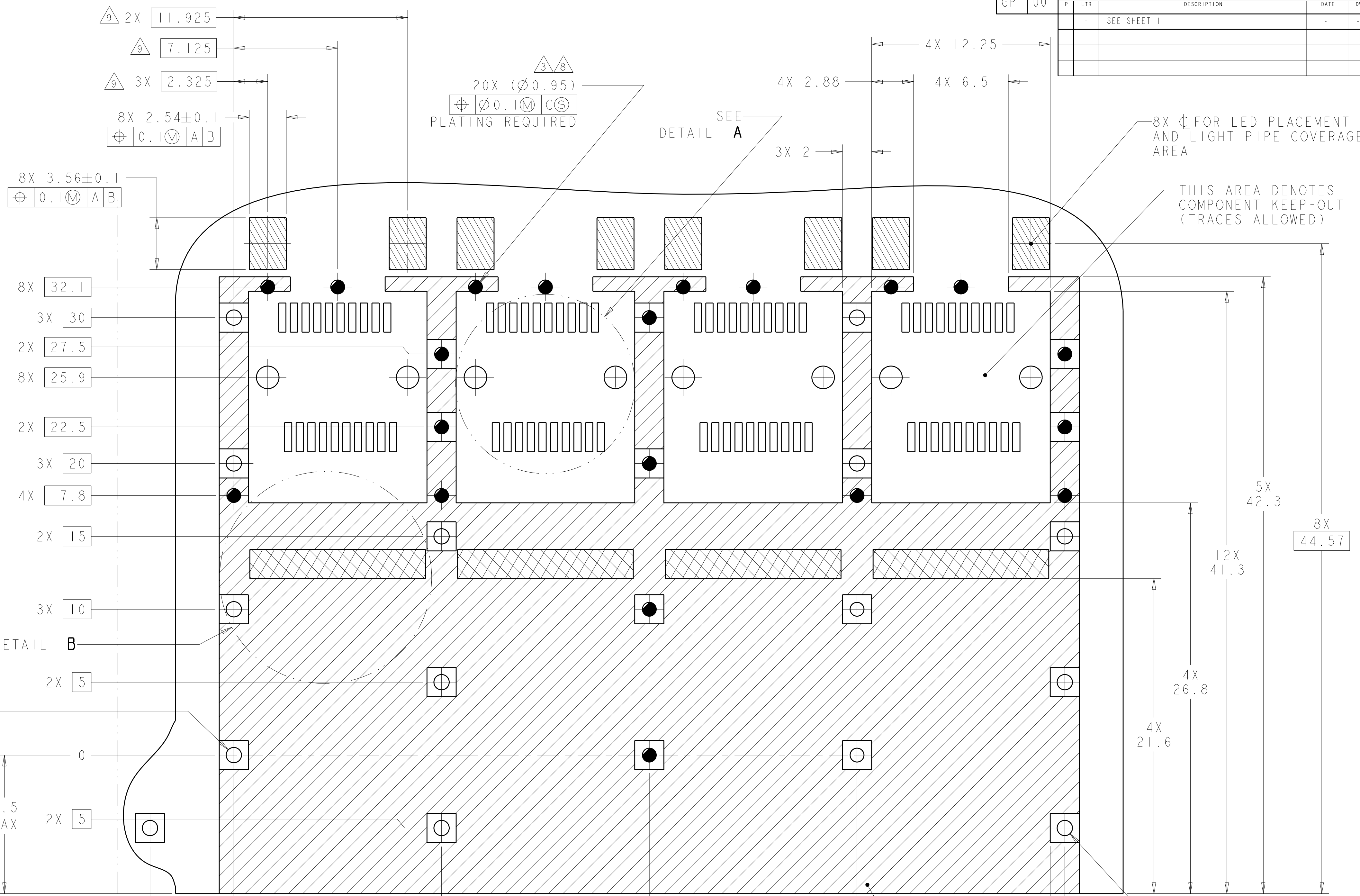
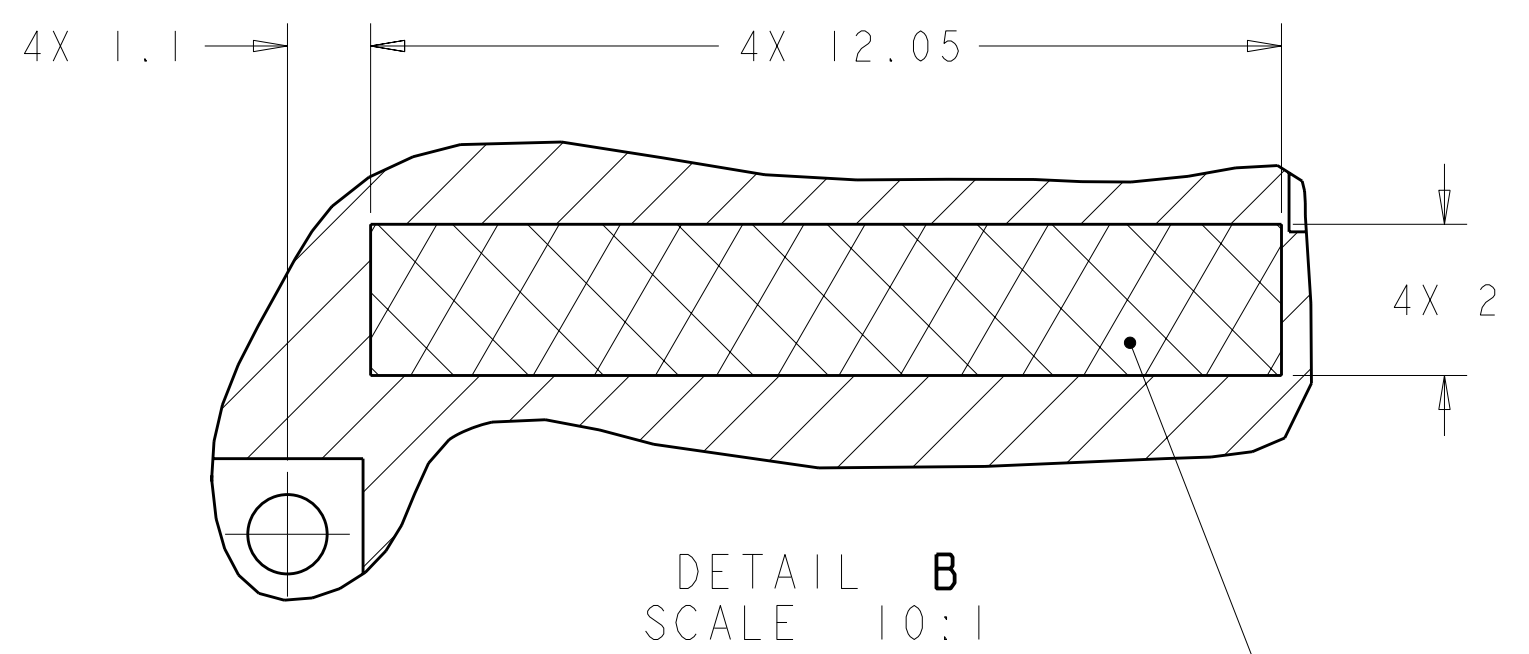

RECOMMENDED PCB CONFIGURATION  
WITH KEEP-OUT AREAS  
SINGLE SIDED APPLICATIONS  
SCALE 6:1

CROSS-HATCHED AREA DENOTES  
COMPONENT AND TRACE KEEP-OUT  
(EXCEPT CHASSIS GROUND)

<small>THIS DRAWING IS UNPUBLISHED. RELEASED FOR PUBLICATION. COPYRIGHT 20 BY TYCO ELECTRONICS CORPORATION, ALL RIGHTS RESERVED.</small> <small>THIS IS SUBJECT TO CHANGE WITHOUT NOTICE. FOR THE LATEST INFORMATION, CONTACT YOUR TYCO ELECTRONICS REPRESENTATIVE.</small>		DWN: MCMASTER 06AUG08 CHK: M. SCHMITT 06AUG08 APVD: M. SCHMITT 06AUG08	Tyco Electronics Harrisburg, PA 17105-3608
DIMENSIONS: mm 	TOLERANCES UNLESS OTHERWISE SPECIFIED: 9 PLC ±0.1 1 PLC ±0.1 5 PLC ±0.1 4 PLC ±0.1 ANGLES ±1	NAME: SFP+ ENHANCED 1X4 CAGE ASSEMBLY PRESS FIT, WITH REDUCED LENGTH LIGHT PIPE APPLICATION SPEC: 114-13120 WEIGHT: - FINISH: - CUSTOMER DRAWING	Tyco Electronics Harrisburg, PA 17105-3608 SIZE: A   00779   C=2057458 SCALE: 5:1 SHEET 3 OF 3 REV A