

LOC		DIST		REVISIONS					
DW		-		P	LTR	DESCRIPTION	DATE	DWN	APVD
				C1		OBSOLETE	12JUN19	K.G	W.H

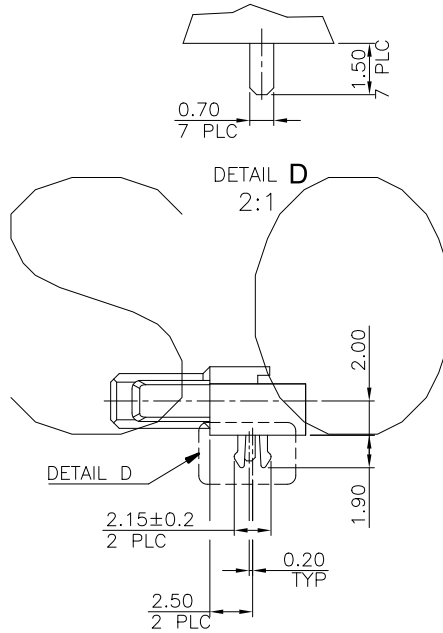

NOTES:

- MATERIAL:  
 HOUSING: PA4T WITH 30% GF, UL94 V-0, BLACK COLOR.  
 CONTACTS: BRASS.  
 BOARDLOCKS: BRASS.
- FINISH:  
 CONTACTS: (SEE TABLE) GOLD PLATED ON CONTACT AREA, 2.54μm [100μ"] MATTE-TIN ON SOLDER TAIL, WITH ENTIRE CONTACT UNDERPLATED 1.27μm [50μ"] MIN. NICKEL.  
 BOARDLOCKS: 2.54μm [100μ"] MIN. MATTE-TIN OVER 1.27μm [50μ"] MIN. NICKEL PLATED.
- REFLOW SOLDER CAPABLE TO 260°C PER TEC-109-201, CONDITION B.
- SUBSTANCE RESTRICTIONS FOR LOW HALOGEN (BY WEIGHT):
  - BROMINE (Br) ≤ 900 PPM (0.09%)
  - CHLORINE (Cl) ≤ 900 PPM (0.09%)
  - TOTAL CONCENTRATION OF (Cl) + (Br) ≤ 1500PPM (0.15%)

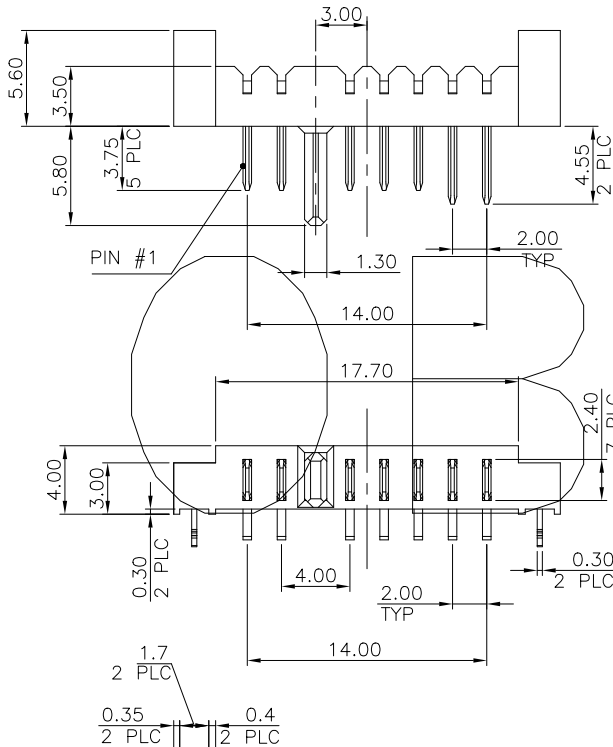
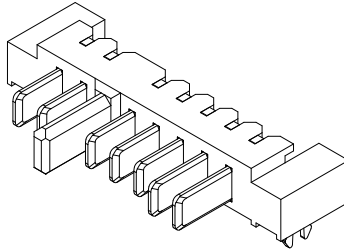
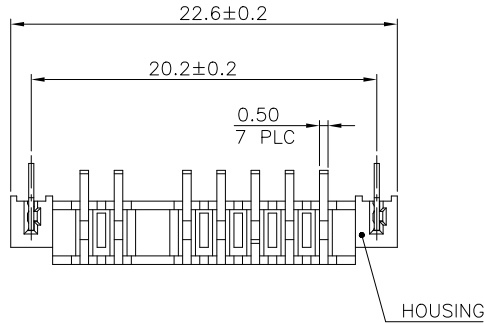
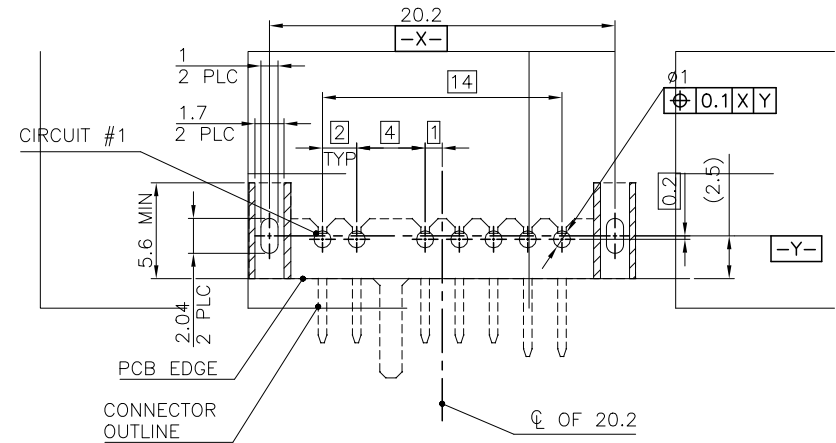

∩: STAND OFF AREA  
 TOLERANCE: ±0.05, THICKNESS: 1.0mm  
 RECOMMENDED PCB LAYOUT  
 (TOP VIEW)

0.152μm [6μ"]	2041552-1
MIN. GOLD THICKNESS	PART NUMBER

THIS DRAWING IS A CONTROLLED DOCUMENT.		DWN A. WU 20JUN2013	TE Connectivity	
DIMENSIONS: MM		CHK S. CHIEN 20JUN2013		
TOLERANCES UNLESS OTHERWISE SPECIFIED:		APVD W. KODAMA 20JUN2013	NAME	
0 PLC ± - 1 PLC ± 0.3 2 PLC ± 0.2 3 PLC ± - 4 PLC ± - ANGLES ± -		PRODUCT SPEC 108-57920	2.0 MM PITCH BATTERY CONNECTOR, 7 POSITION, 4 MM HEIGHT, PLUG	
MATERIAL SEE NOTE		APPLICATION SPEC -	SIZE A3	RESTRICTED TO -
FINISH SEE NOTE		WEIGHT 0.9g	CAGE CODE 00779	DRAWING NO C=2041552
		RESTRICTED CUSTOMER	SCALE -	SHEET 1 OF 2
				REV C1

THIS DRAWING IS UNPUBLISHED. RELEASED FOR PUBLICATION  
 © COPYRIGHT 2013 BY TE CONNECTIVITY. ALL RIGHTS RESERVED.

LOC		DIST		REVISIONS					
DW		-		P	LTR	DESCRIPTION	DATE	DWN	APVD
SEE SHEET 1									

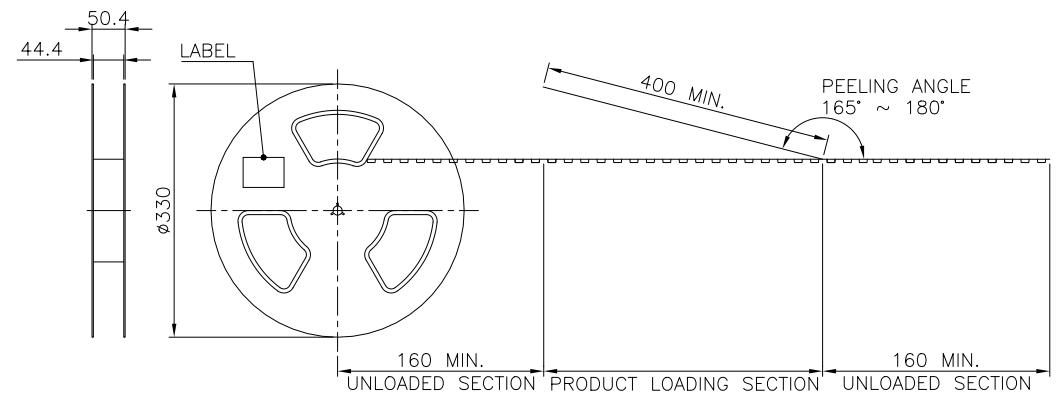

NOTES:

- MATERIAL:  
 BOX: FIBREBOARD, CORRUGATED, DOUBLE WALL.  
 COVER TAPE: POLYSTYRENES, TRANSPARENT COLOR.  
 CARRIER TAPE: POLYSTYRENES, BLACK COLOR.  
 REEL: HIPS, BLUE COLOR.  
 BAG: POLYETHYLENES, TRANSPARENT COLOR.
- EACH BAG SHALL BE INCLUDED DESICCANT.
- PEELING STRENGTH: 0.1 ~ 1.3 N (10 ~ 130 GRAMS).
- PEELING SPEED: 300 mm/min.

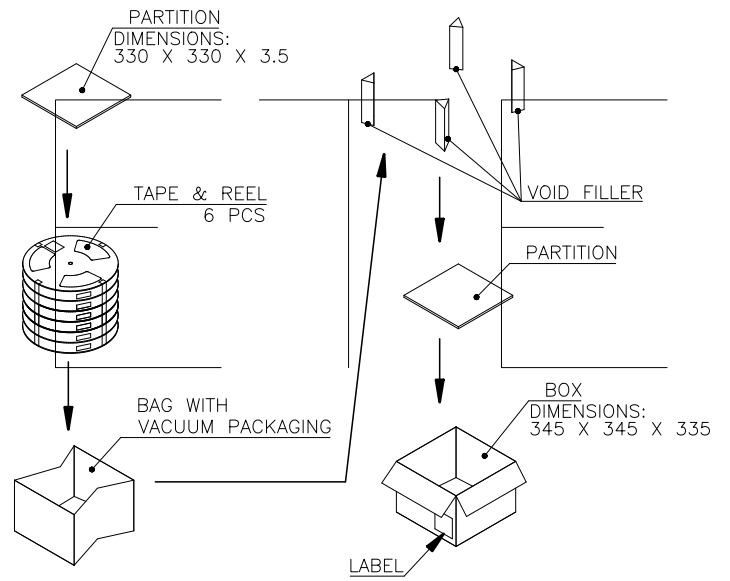
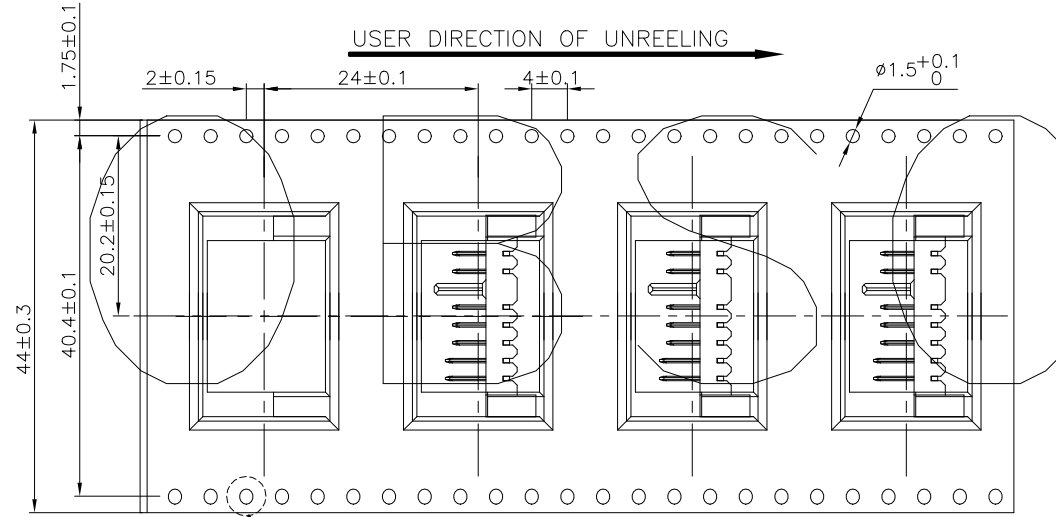

1.62 Kg	1.81 Kg	300	6	1800
NET WEIGHT	GROSS WEIGHT	PCS/TAPE	REELS/BOX	PCS/BOX

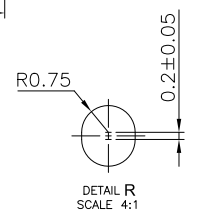

THIS DRAWING IS A CONTROLLED DOCUMENT.		DWN	-		
		CHK	-		
		APVD	-		
		PRODUCT SPEC	-		
		APPLICATION SPEC	-		
		WEIGHT	-		
		RESTRICTED CUSTOMER			SCALE -
		SHEET 2 OF 2		REV C1	

DIMENSIONS: MM		TOLERANCES UNLESS OTHERWISE SPECIFIED:		NAME	
0 PLC	± -	/		-	
1 PLC	± -	/		-	
2 PLC	± -	/		-	
3 PLC	± -	/		-	
4 PLC	± -	/		-	
ANGLES	± -	/		-	
MATERIAL		FINISH		-	

TE Connectivity		2.0 MM PITCH BATTERY CONNECTOR, 7 POSITION, 4 MM HEIGHT, PLUG	
SIZE	CAGE CODE	DRAWING NO	RESTRICTED TO
A3	00779	C=2041552	-