

THIS DRAWING IS UNPUBLISHED. RELEASED FOR PUBLICATION
 © COPYRIGHT copyright.dBTe- TE Connectivity ALL RIGHTS RESERVED.

REVISIONS					
P	LTR	DESCRIPTION	DATE	DWN	APVD
	A	RELEASED	05NOV2008	YD.	HG
	A1	REVISED (ECR-17-009686)	13JUL2017	SJ	KT

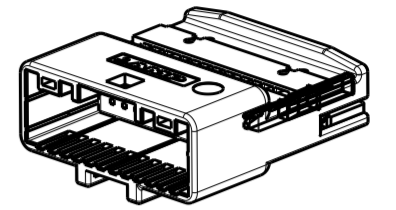
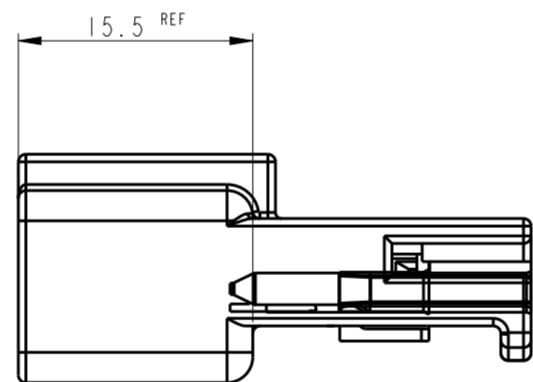
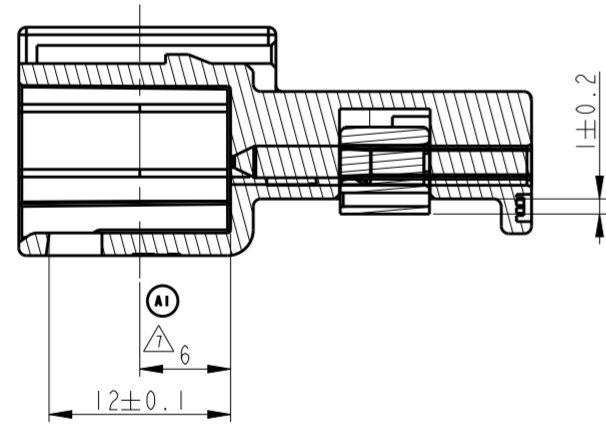
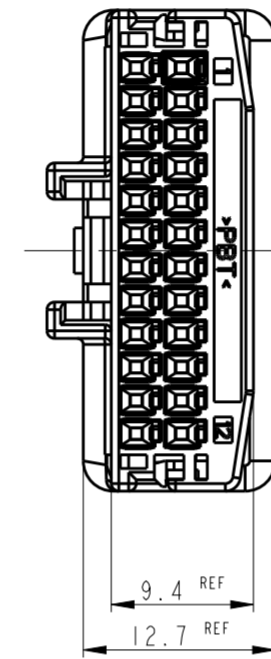
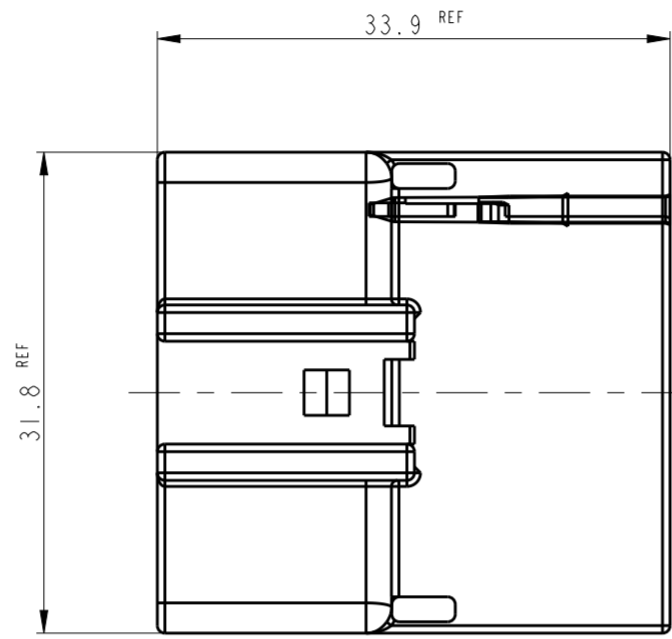
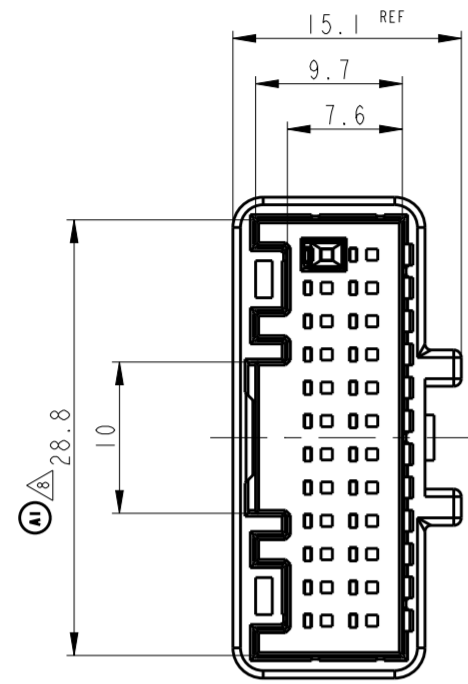

ISO VIEW
SCALE 1:1

[TABLE 2]

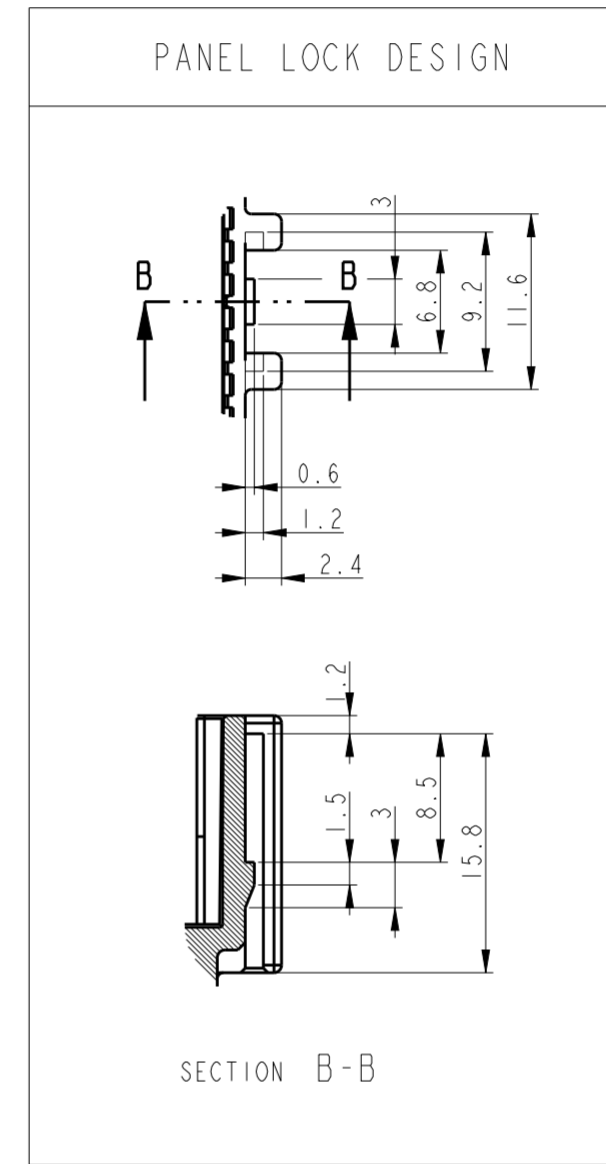

[TABLE 1]

P/NO	FINISH	WIRE RANGE
2005098-1	PRE-TIN	CHFUS 0.13-0.22 SQ
2005154-1	PRE-TIN	AVSS 0.3-0.5 SQ

NOTE

1. DBL MUST BE SET TO THE PRE-ASSEMBLY POSITION WITHIN THE CAP HOUSING WHEN SHIPPED TO THE CUSTOMER
2. DBL MUST BE OUT SIDE OF CAP HOUSING AT PRE-ASSEMBLY
3. PART NUMBER OF PLUG HOUSING TO BE MATED : 2005082
4. APPLICABLE TERMINAL : TABLE 1
5. PANEL LOCK VARIATIONS : REFER TO TABLE 2

- ⑥ GENERAL TOLERANCE : ±0.3, ±3°
- ④ MEASURING RANGE AT MARKED Ⓐ

NO.	COLOR/FINISH	MATERIAL	DESCRIPTION	QT'Y
2	NATURAL	PBT	24P DBL HSG	1
1	NATURAL	PBT	24P CAP HSG	1

THIS DRAWING IS A CONTROLLED DOCUMENT.

DWN: YD.LEE
CHK: YM.CHOI
APVD: HG.CHOI
PRODUCT SPEC

APPLICATION SPEC

WEIGHT

CUSTOMER DRAWING

SCALE: 2:1 SHEET: 1 OF 1 REV: A1

2005085-1 24P CAP ASS'Y DESCRIPTION 2005085-1 ASS'Y P/N

2 2 NATURAL PBT 24P DBL HSG 1

1 1 NATURAL PBT 24P CAP HSG 1

NO. COLOR/FINISH MATERIAL DESCRIPTION QT'Y

STE TE Connectivity

NAME: 025 24P CAP ASS'Y

SIZE: A2 CAGE CODE: 00779 DRAWING NO: C-2005085 RESTRICTED TO: -