

LOC		DIST		REVISIONS			
FT	0	P	LTH	DESCRIPTION	DATE	DWN	APVD
		3		2-1986777-6 PART UPDATED	18JAN2013	KH	MB

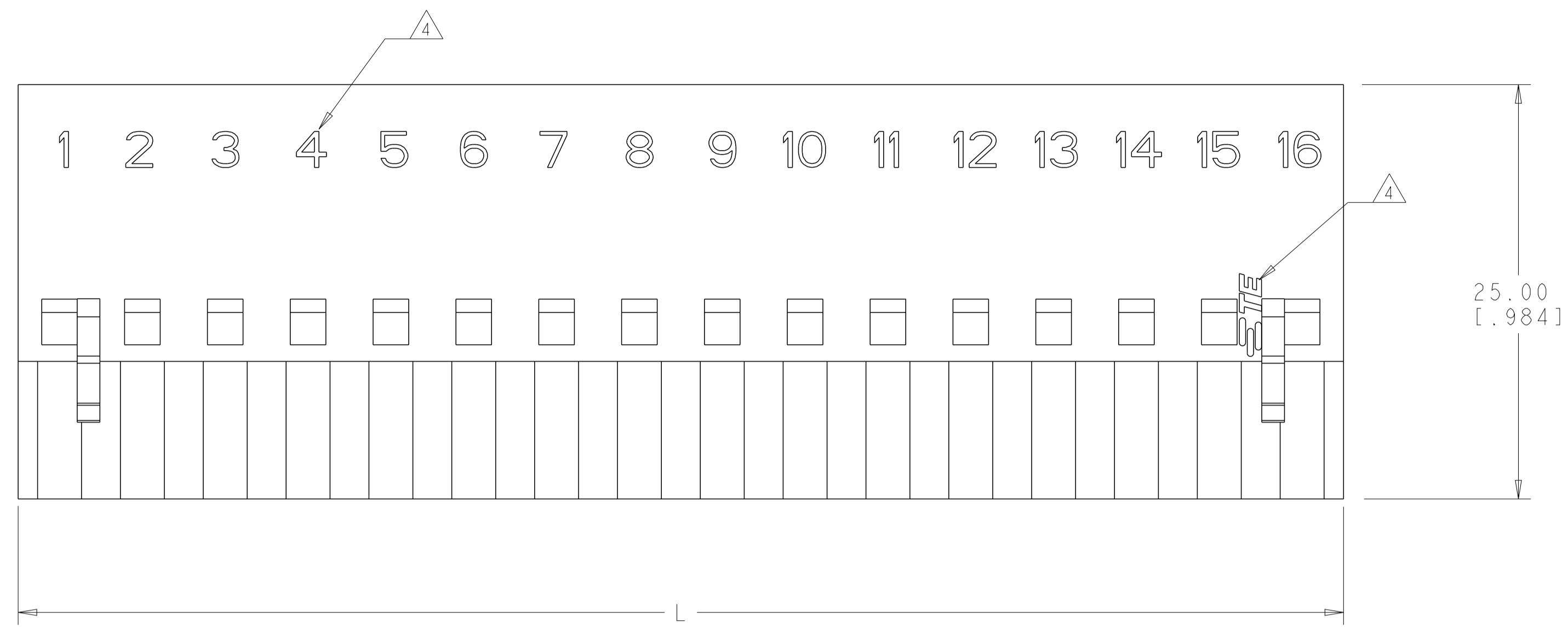

1. MATERIAL:  
HOUSING - POLYESTER, UL 94V-0 RATED, COLOR: SEE TABLE.
  2. RECOMMENDED CRIMP STYLE CONTACTS, (TO BE DETERMINED)  
TO BE USED WITH THIS HOUSING.
  3. CONNECTOR MATES WITH 5.00mm OPEN AND CLOSED END  
INDUSTRY STANDARD HEADERS.
- A** PART TO BE MARKED WITH BLACK PERMANENT MARKING  
SEE DETAIL C, LETTER TO BE 3.8 MM IN HEIGHT

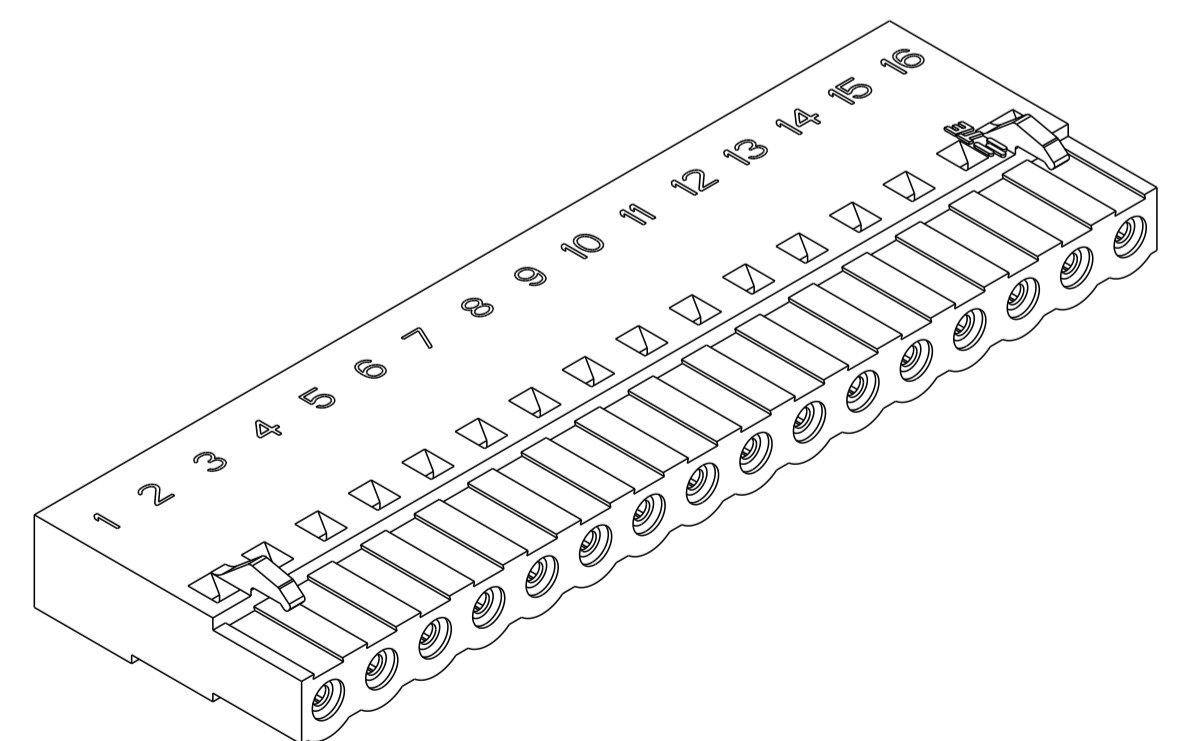
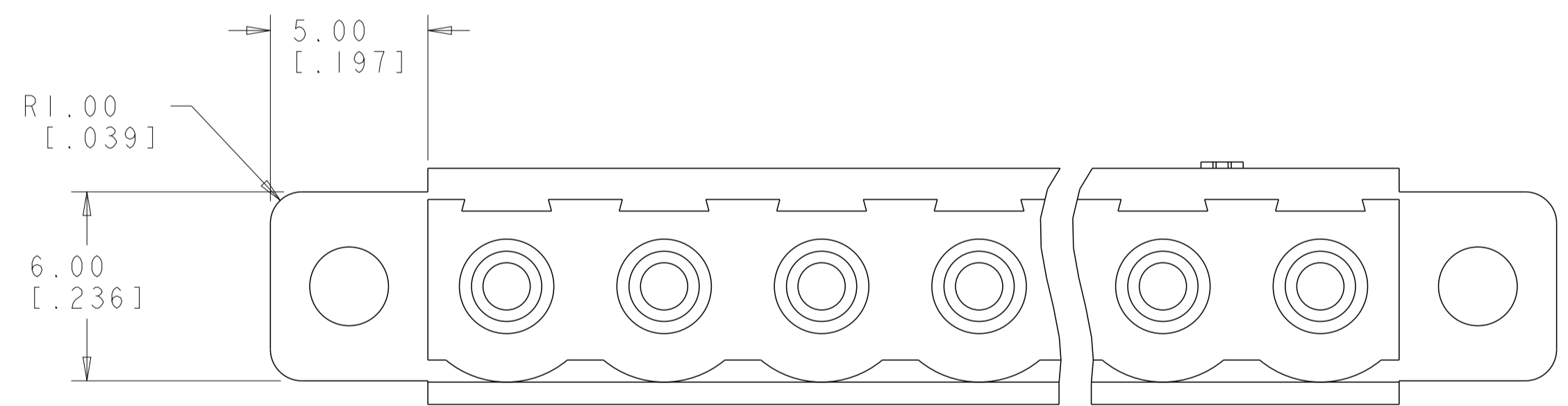
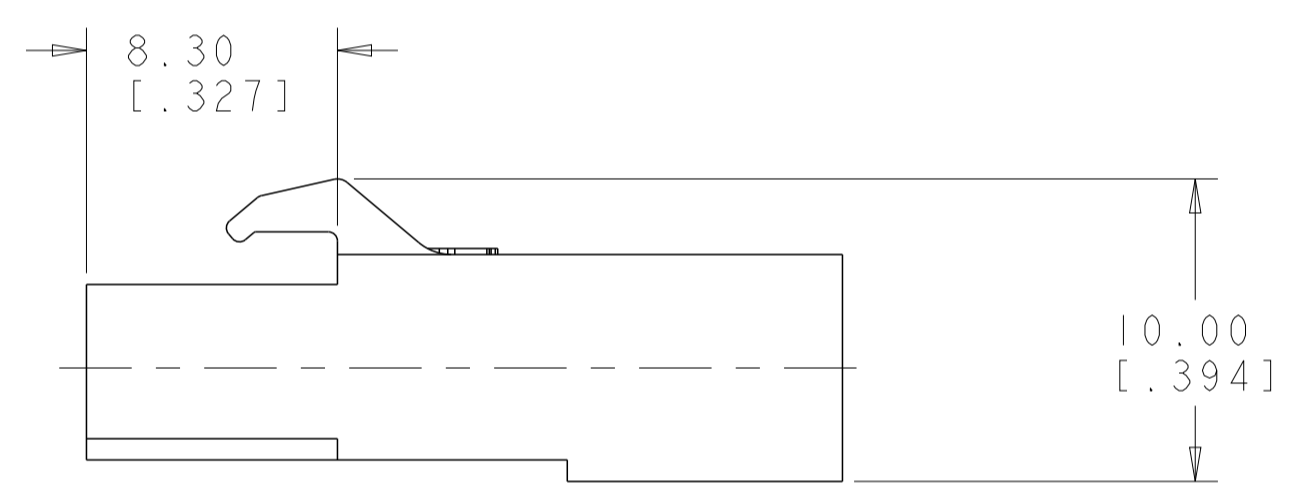
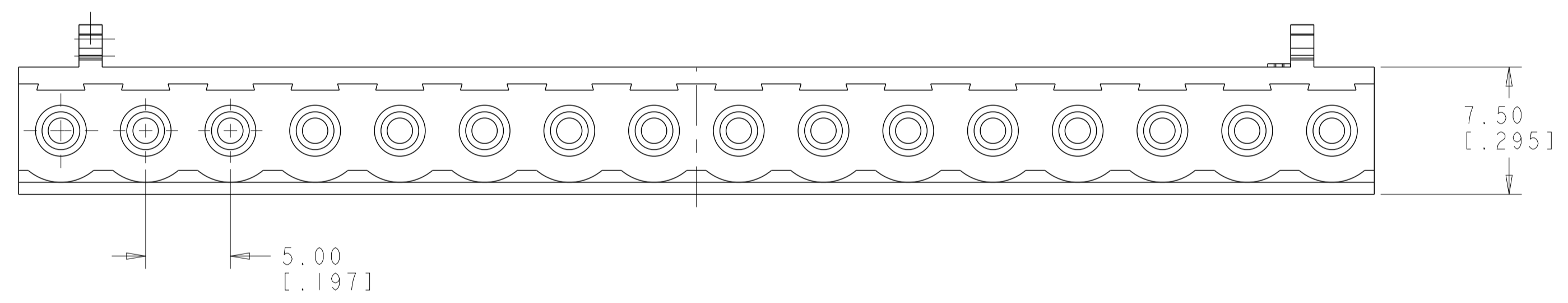

2-1986777-6 AS SHOWN

BLACK	80.00 [3.150]	16	2-1986777-6
BLACK	80.00 [3.150]	16	1-1986777-6
HOUSING COLOR	L	NO OF POSITION	PART NUMBER

**PRELIMINARY PART  
 NOT RELEASED FOR PRODUCTION**

THIS DRAWING IS A CONTROLLED DOCUMENT.		DWN KIRAN HOLAL 05JAN2013	TE Connectivity	
DIMENSIONS: mm [ INCHES ]		CHK BRUBAKER, MARK 05JAN2013	NAME PLUG HOUSING, TERMINAL BLOCK, CRIMP STYLE, 5.00mm PITCH	
TOLERANCES UNLESS OTHERWISE SPECIFIED:		APVD BRUBAKER, MARK 05JAN2013	RESTRICTED TO	
0 PLC ± .5	1 PLC ± .5	PRODUCT SPEC	SIZE CAGE CODE DRAWING NO	
2 PLC ± .13	3 PLC ± .000	APPLICATION SPEC	A100779C=1986777	
4 PLC ± .0000	ANGLES ± .1*	WEIGHT	SCALE 4:1 SHEET 1 OF 1 REV 3	
MATERIAL	FINISH	CUSTOMER DRAWING		