

THIS DRAWING IS UNPUBLISHED. RELEASED FOR PUBLICATION  
 © COPYRIGHT - By - ALL RIGHTS RESERVED.

LOC		DIST		REVISIONS			
P	LTR	DESCRIPTION	DATE	DWN	APVD		
B		REV PER ECO 15-017751	12-18-15	CT	PD		

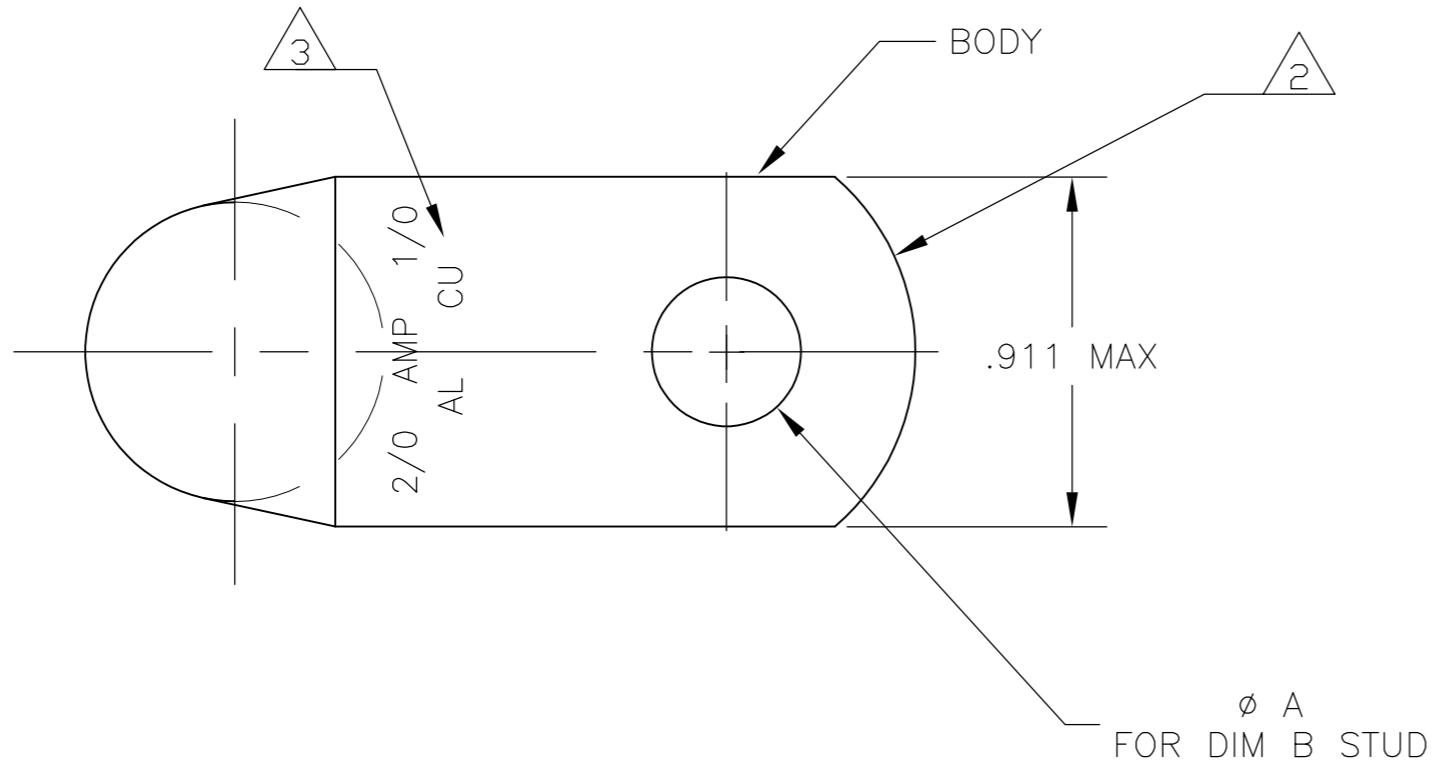

- 1 WIRE INSULATION: .500-.550 DIA
- △2 THE TONGUE RADIUS FEATURE IS NOT A TOOLING CONTROLLED DIMENSION AND MAY NOT BE A TRUE RADIUS.
- △3 STAMP " 2/0 AMP 1/0 "  
" AL CU "  
SIZE AND LOCATION APPROX AS SHOWN

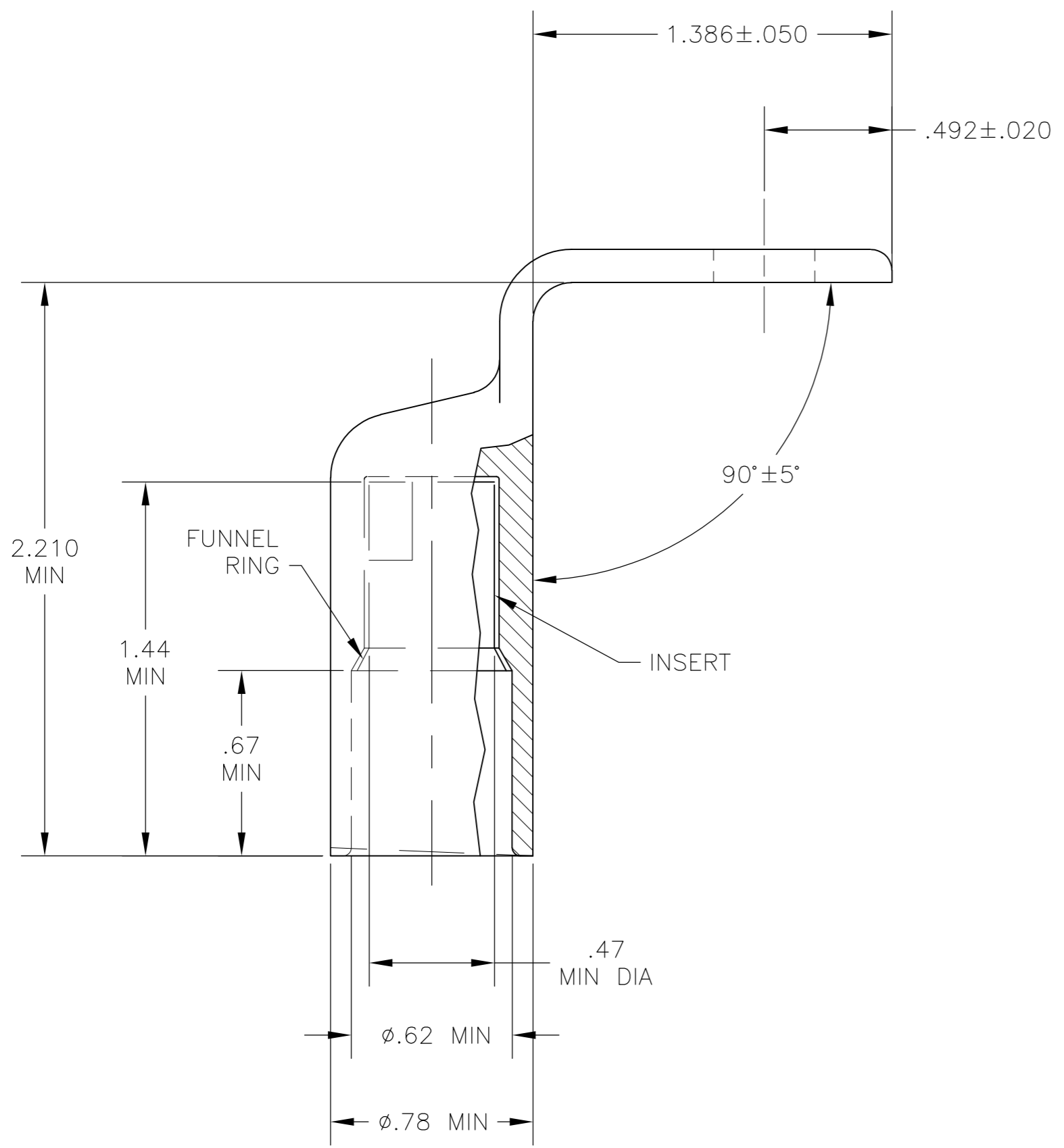

5/16	.328 ± .005	BODY: COPPER ASTM-B187 ANNEALED TIN PL PER ASTM B545, .000150 MIN THK INSERT & FUNNEL: BRASS MIL-C-50 NICKEL PL QQ-N-290 .000300 AVG THK	1958038-2
3/8	.390 ± .005	BODY: COPPER ASTM-B187 ANNEALED TIN PL PER ASTM B545, .000150 MIN THK INSERT & FUNNEL: BRASS MIL-C-50 NICKEL PL QQ-N-290 .000300 AVG THK	1958038-1
DIM B	DIM A	MATERIAL & FINISH	PART NO.

THIS DRAWING IS A CONTROLLED DOCUMENT.		DWN JR RUTH 06NOV06	<b>STE</b> TE Connectivity	
DIMENSIONS: INCHES		CHK MJ SPICER 06NOV06		
TOLERANCES UNLESS OTHERWISE SPECIFIED:		APVD MJ SPICER 06NOV06	NAME RING TONGUE, BENT, SEALED COPALUM, WIRE SIZE: 2/0 AL	
0 PLC ± - 1 PLC ± - 2 PLC ± - 3 PLC ± .008 4 PLC ± - ANGLES ± - FINISH		PRODUCT SPEC APPLICATION SPEC	RESTRICTED TO	
MATERIAL		WEIGHT	SIZE A2	CAGE CODE 00779
		CUSTOMER DRAWING	DRAWING NO C=1958038	SCALE 2:1
			SHEET 1 of 1	REV B