

4

3

2

1

THIS DRAWING IS UNPUBLISHED. RELEASED FOR PUBLICATION 20  
 © COPYRIGHT 20 BY - ALL RIGHTS RESERVED.

LOC	DIST	REVISIONS						
AF	50	P	LTR	DESCRIPTION	DATE	DWN	APVD	
				5	UPDATED VIEWS	26FEB13	JR	DF

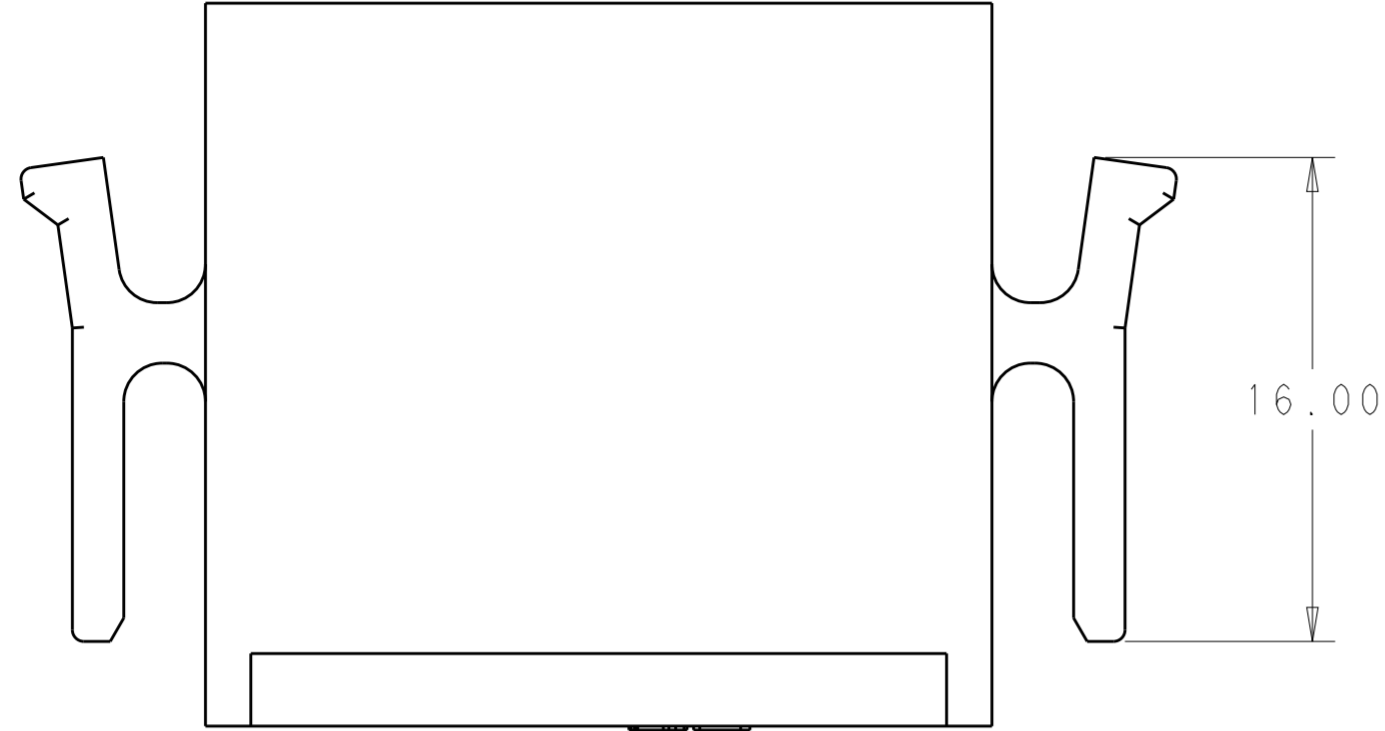

⚠ PRELIMINARY - NOT FOR PRODUCTION

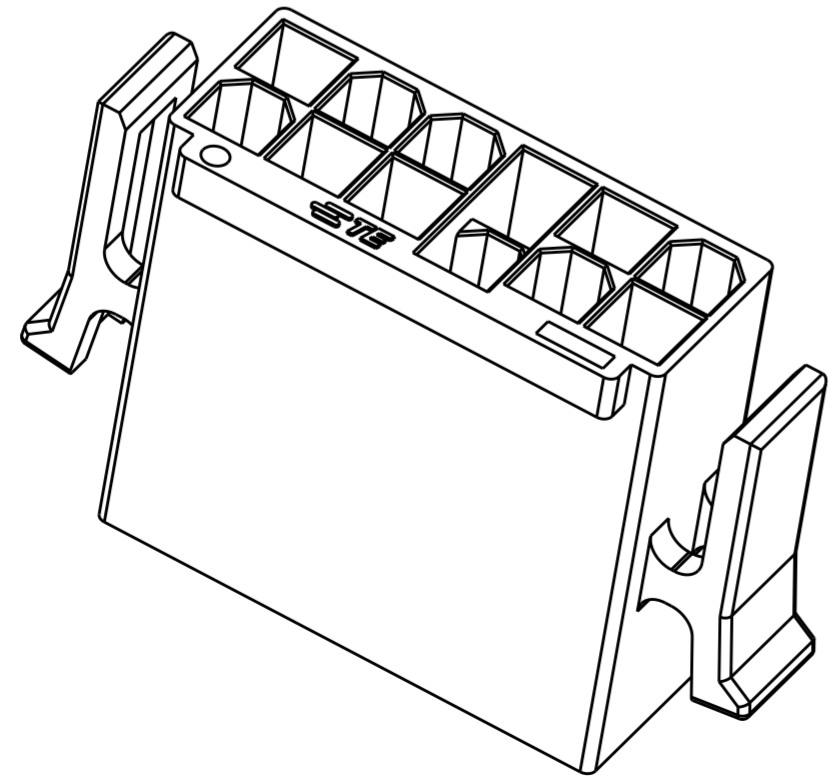
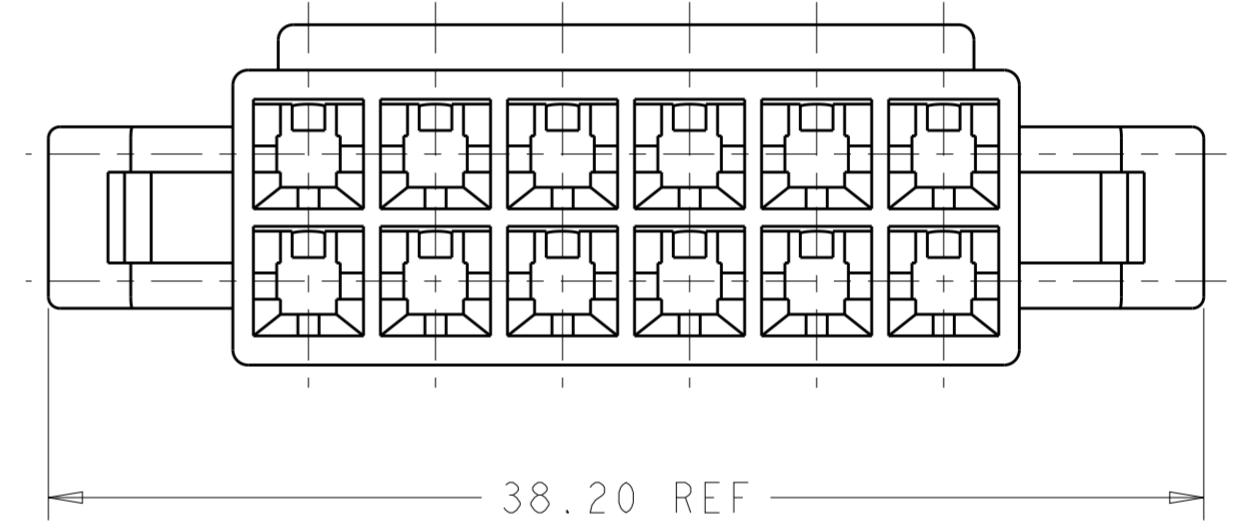
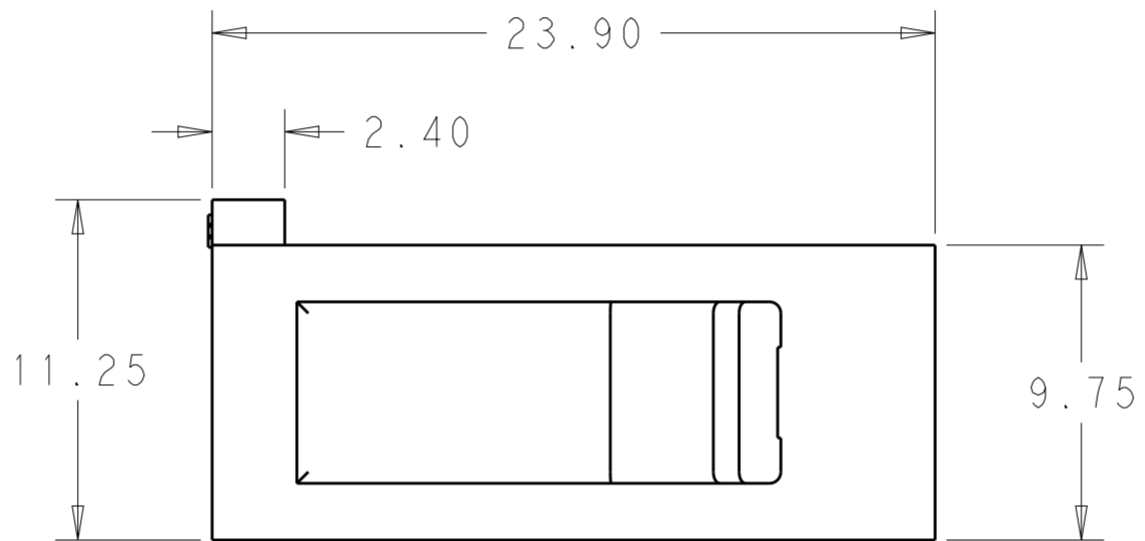
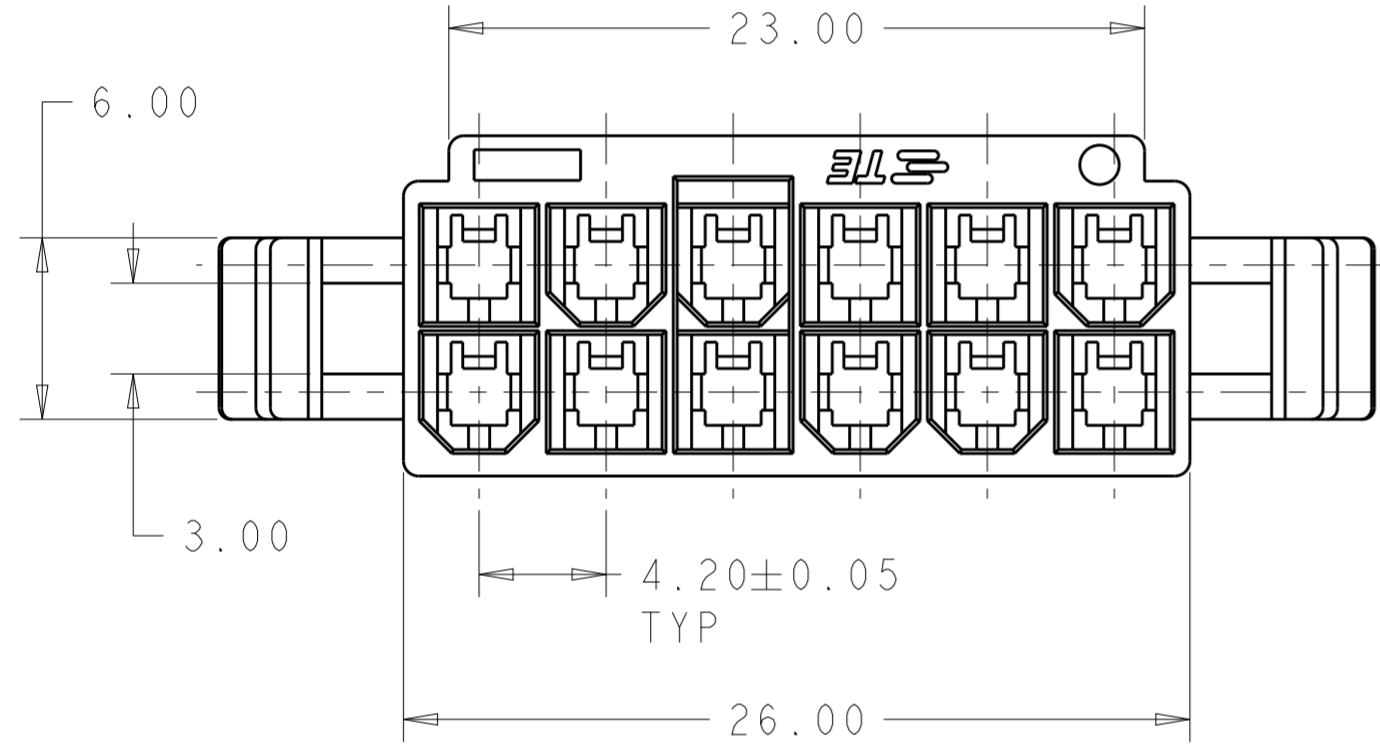

SCALE 3:1

⚠ 1744450-1  
PART NO.

THIS DRAWING IS A CONTROLLED DOCUMENT.		DWN	JR RUTH	19APR12	TE Connectivity	NAME			HOUSING HEADER, VAL-ULOK, 12 POSITION
DIMENSIONS:		CHK	DOMINIC FAROLE	19APR12		SIZE			A200779
mm		APVD	DOMINIC FAROLE	19APR12		CAGE CODE			C-1744450
TOLERANCES UNLESS OTHERWISE SPECIFIED:		PRODUCT SPEC		DRAWING NO			RESTRICTED TO	-	
0 PLC ±		APPLICATION SPEC		WEIGHT			SCALE	4:1	
1 PLC ±		-		MATERIAL			SHEET	1	
2 PLC ±0.13		-		NYLON 66			OF	1	
3 PLC ±		-		COLOR- WHITE			REV	5	
4 PLC ±		-		Customer Drawing					
ANGLES ±		-							
FINISH		-							