

ASSEMBLED VIEWS / Assembled Views

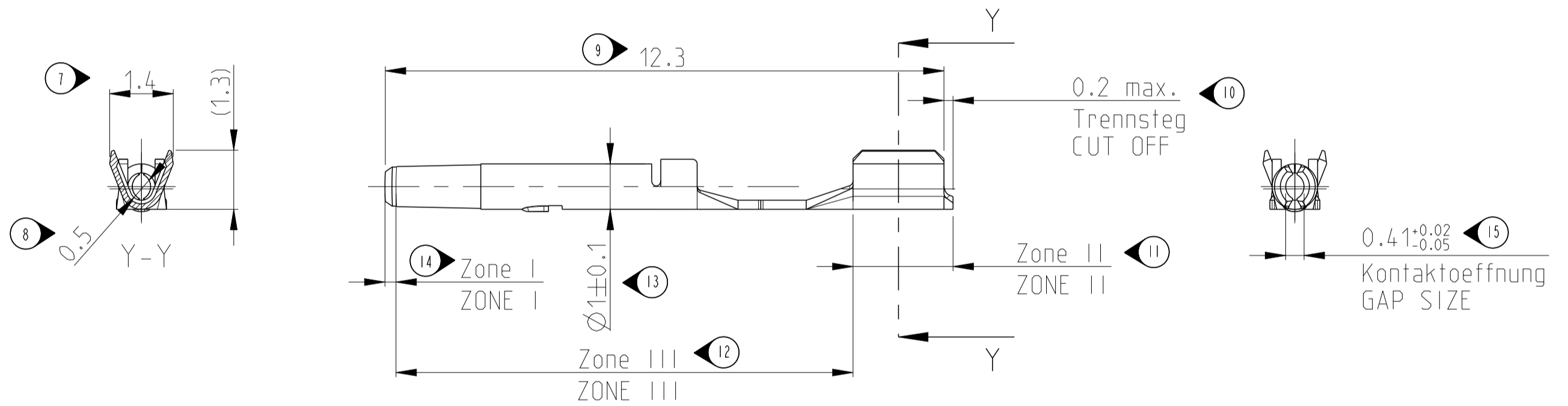

CENTER CONTACT (ITEM 2) / Innenleiter (Item 2)

CABLE TYPES Kabeltypen	φ "A"	φ "B"	φ "C"	φ "D"
RG174 (TE-P/N 1449103-1)				
RG174 (TE-P/N 1719435-1)	φ0,48 nom.	φ1,52±0.07	φ1,92±0.10	φ2,80±0.10
DACAR 462 (TE-P/N 1557725-1)				

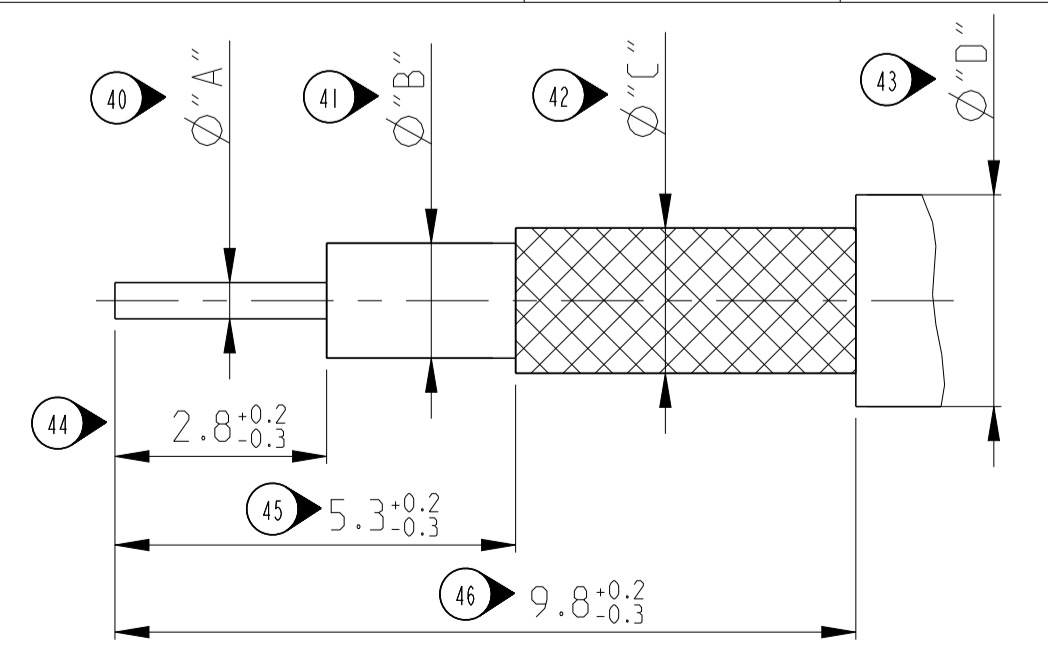

RECOMMENDED STRIP DIMENSIONS / Empfohlene Abisolierdimensionen  
 SEE APPLICATION SPECIFICATION / Siehe Verarbeitungsspezifikation

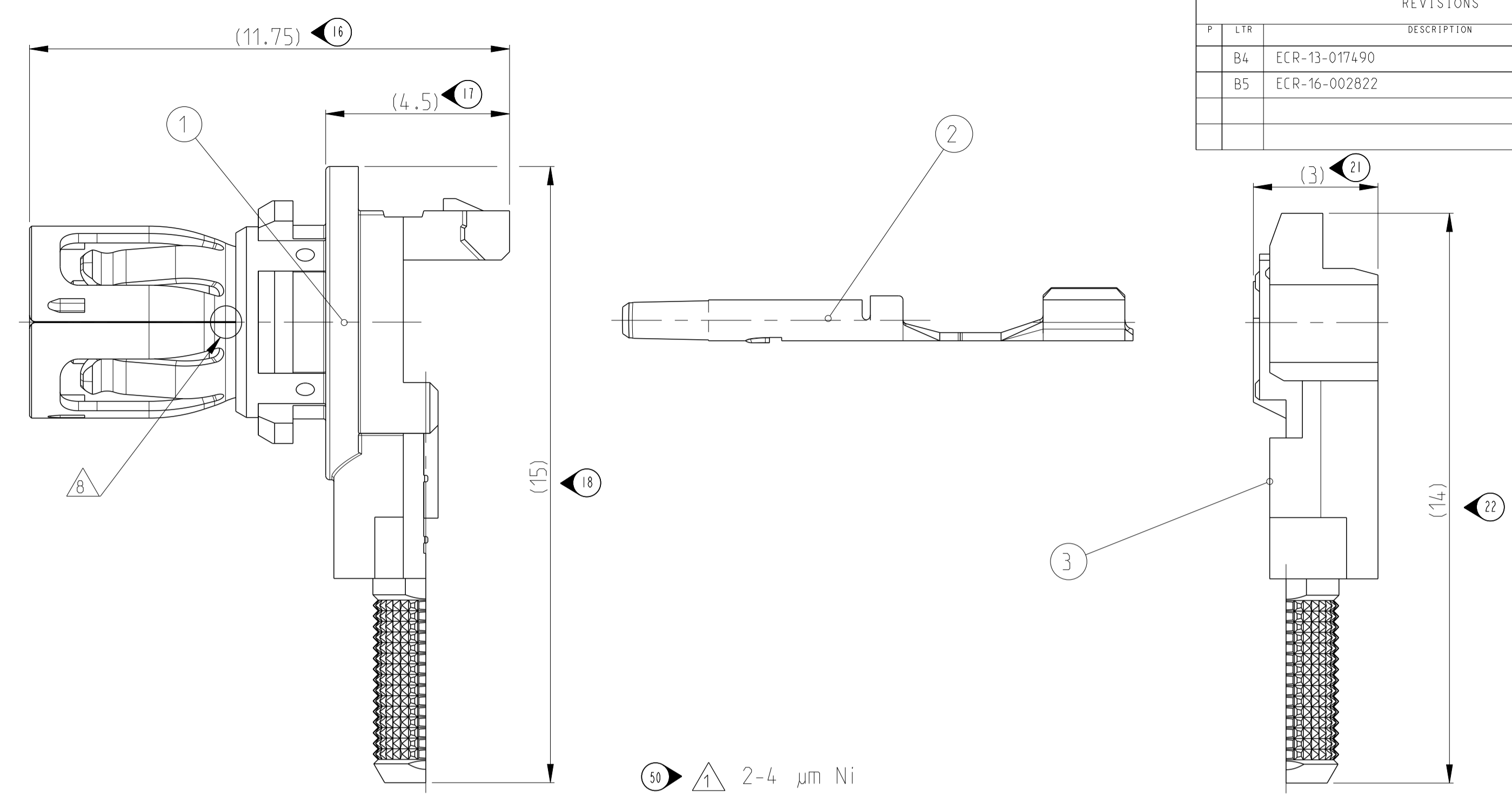

- 50 1 2-4 μm Ni
- 51 2 2-4 μm Sn OVER 1.27 μm MIN. Ni OVER 5.08 μm MIN. Cu  
2-4 μm Sn ueber min. 1.27 μm Ni ueber min. 5.08 μm Cu}
- 52 3 ZONE I: 0.8 μm MIN. Au OVER 1.3 μm MIN. Ni  
ZONE II: 2-4 μm Sn OVER 0.1 μm MIN. Ni  
ZONE III: 0.1 μm MIN. Ni  
Zone I: min. 0.8 μm Au ueber min. 1.3 μm Ni  
Zone II: 2-4 μm Sn ueber min. 0.1 μm Ni  
Zone III: min. 0.1 μm Ni
- 53 4 PRETINNED (1-3 μm Sn)  
Vorverzinnt (1-3 μm Sn)
- 54 5. THE CONNECTOR MUST FULFILL THE DIMENSIONAL REQUIREMENTS OF DIN 72594-1, RELEASED MARCH 2006, AND THE MECHANICAL AND ELECTRICAL REQUIREMENTS OF USCAR 17 REV. 2. Der Kuppler muss die dimensionellen Anforderungen nach DIN 72594-1, Ausgabe Maerz 2006, und die elektrischen und mechanischen Anforderungen nach SAE/USCAR 17 rev. 2 erfullen.
- 55 6 COMPONENTS MUST BE PURCHASED SEPARATELY.  
Komponenten sind separat zu bestellen.
- 56 7 CRIMP TO BE MEASURED AT THIS POINT SEE APPLICATION SPECIFICATION.  
Crimp an diesem Punkt zu Messen Ausfuehrung siehe Verarbeitungsspezifikation.
- 57 8 WELDING POINT  
Schweißpunkt
- 58 9. CHARACTERS ON THE PARTS STAND FOR THE REVISION OF THAT COMPONENT, NOT OF THE SUBASSEMBLY OR ASSEMBLY.  
Die Buchstaben auf den Teilen stehen fuer die Revision der entsprechende Komponente, nicht des Subassembly oder Assembly.

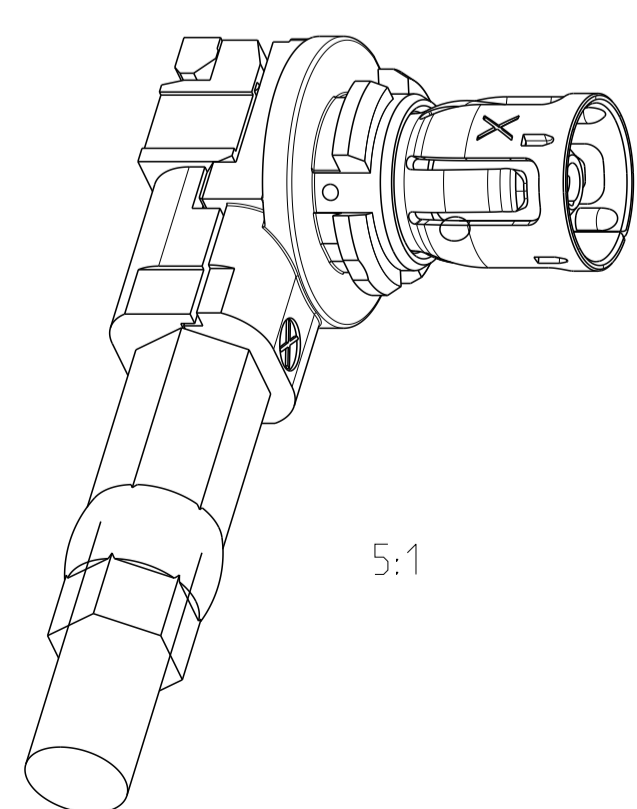

ITEM NO	DESCRIPTION	MATERIAL	PLATING
1	FERRULE Crimphuelse	SfCu	1
1	REAR SHELL SUBASSY Hinterschale (Deckel)	3a. PBT 3b. Zn-Leg. Zn-ALLOY	2
1	CENTER CONTACT Innenleiterkontakt	CuNiSi	3
-	CENTER CONTACT Innenleiterkontakt	CuNiSi	3
1	FRONT SHELL SUBASSY Subassembly	1a. CuNiSi 1b. PEHD 1c. Zn-Leg. Zn-ALLOY	4 2

THIS DRAWING IS A CONTROLLED DOCUMENT. DWN 07-Apr-06  
 DIMENSIONS: mm TOLERANCES UNLESS OTHERWISE SPECIFIED:  
 0 PLC ±0.5  
 1 PLC ±0.2  
 2 PLC ±0.1  
 3 PLC ±0.1  
 4 PLC ±0.1  
 ANGLES ±°  
 MATERIAL: siehe Tabelle SEE TABLE FINISH: siehe Tabelle SEE TABLE

REVISIONS

P	LTN	DESCRIPTION	DATE	DMN	APVD
B4	ECR-13-017490		25OCT2013	SR	VC
B5	ECR-16-002822		25FEB2016	VH	NR

PRODUCT SPEC: 108-94089 APPLICATION SPEC: 114-18623 WEIGHT: - CUSTOMER DRAWING

SCALE: 10:1 SHEET 1 OF 1 REV: B5

TE Connectivity  
 HF FAKRA 90DEG. CONTACT KIT. PLUG. TURNABLE VERSION. RG174. DACAR 462. UNASSEMBLED