

LOC		DIST		REVISIONS			
P	LTN	DESCRIPTION	DATE	OWN	APVD		
A		NEW PART. NEW DRAWING	14DEC2007	YA	HR		
A1		PCN-E-08-027108	26MAY2009	YA	HR		
B		E-09-026750	08DEC2009	YA	HR		
B1		NEW PN 4-1703941-1 ADDED	14FEB2016	RS	YA		

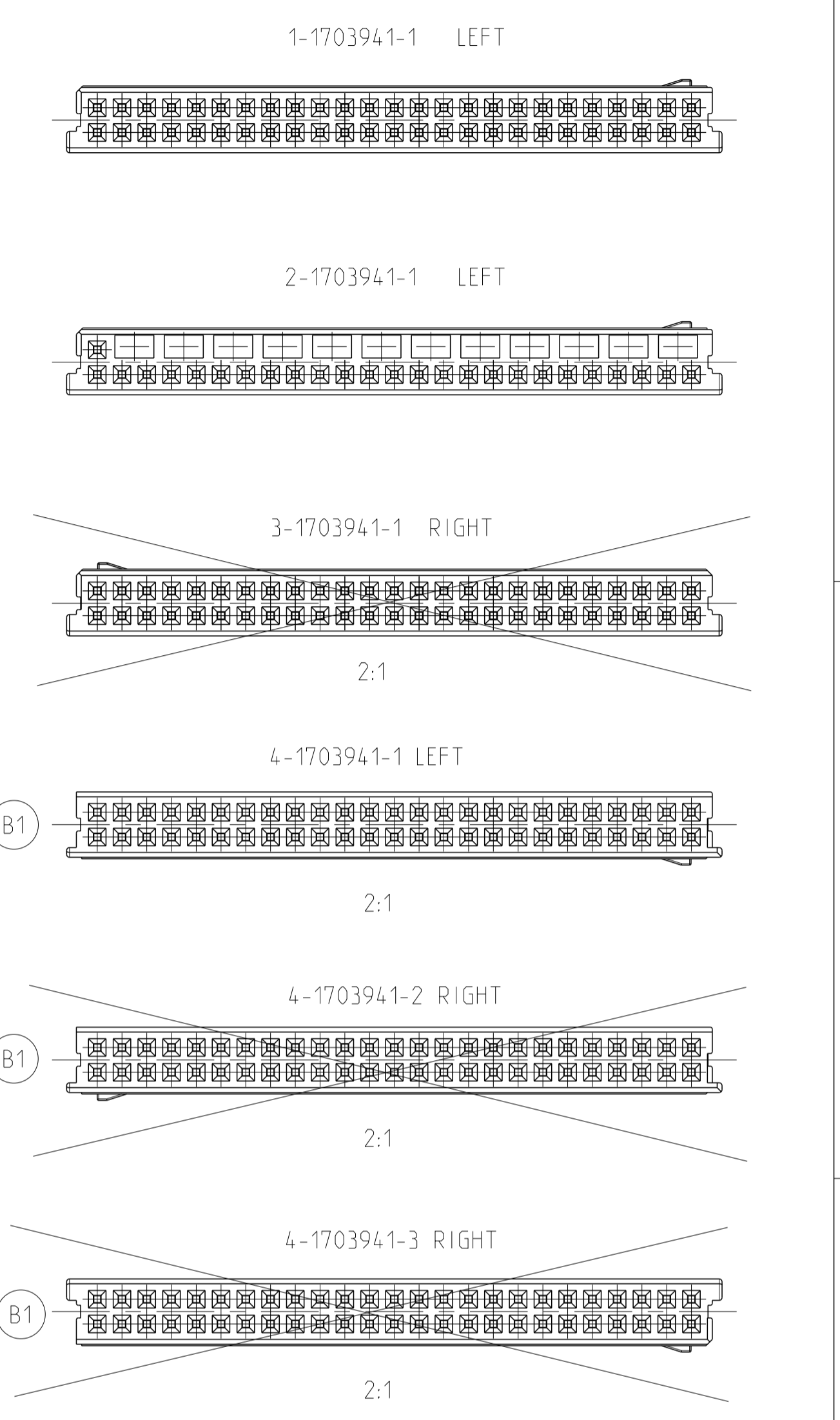

- NOTES:  
 Bemerkungen:
- 1 CAVITY MARKING  
Nestmarkierung
  - 2 TE-LOGO  
TE-Logo
  - 3 CONTACT CAVITY NUMBER  
Kontaktkammernummer
  - 4 PRODUCTION DATE  
Produktionsdatum
  - 5 TE PART NO.  
TE Teile Nr.
  - 6 PART REVISION  
Teile Revision
  - 7 MATERIAL IDENTIFICATION  
Werkstoffkennzeichnung
  - 8 BULK PACKAGED  
Verpackt als Schuetztgut

RECOMMENDED TERMINALS, TE ORDER NO.  
 963715-X WSR 0.5-0.75 (mm<sup>2</sup>), u. 928999-X, WSR 0.25-0.5 (mm<sup>2</sup>)  
 Empfohlene Kontakte, TE Bestellnr.  
 963715-X WSR 0.5-0.75 (mm<sup>2</sup>), u. 928999-X, WSR 0.25-0.5 (mm<sup>2</sup>)

VERSION - LEFT  
 2-1703941-1

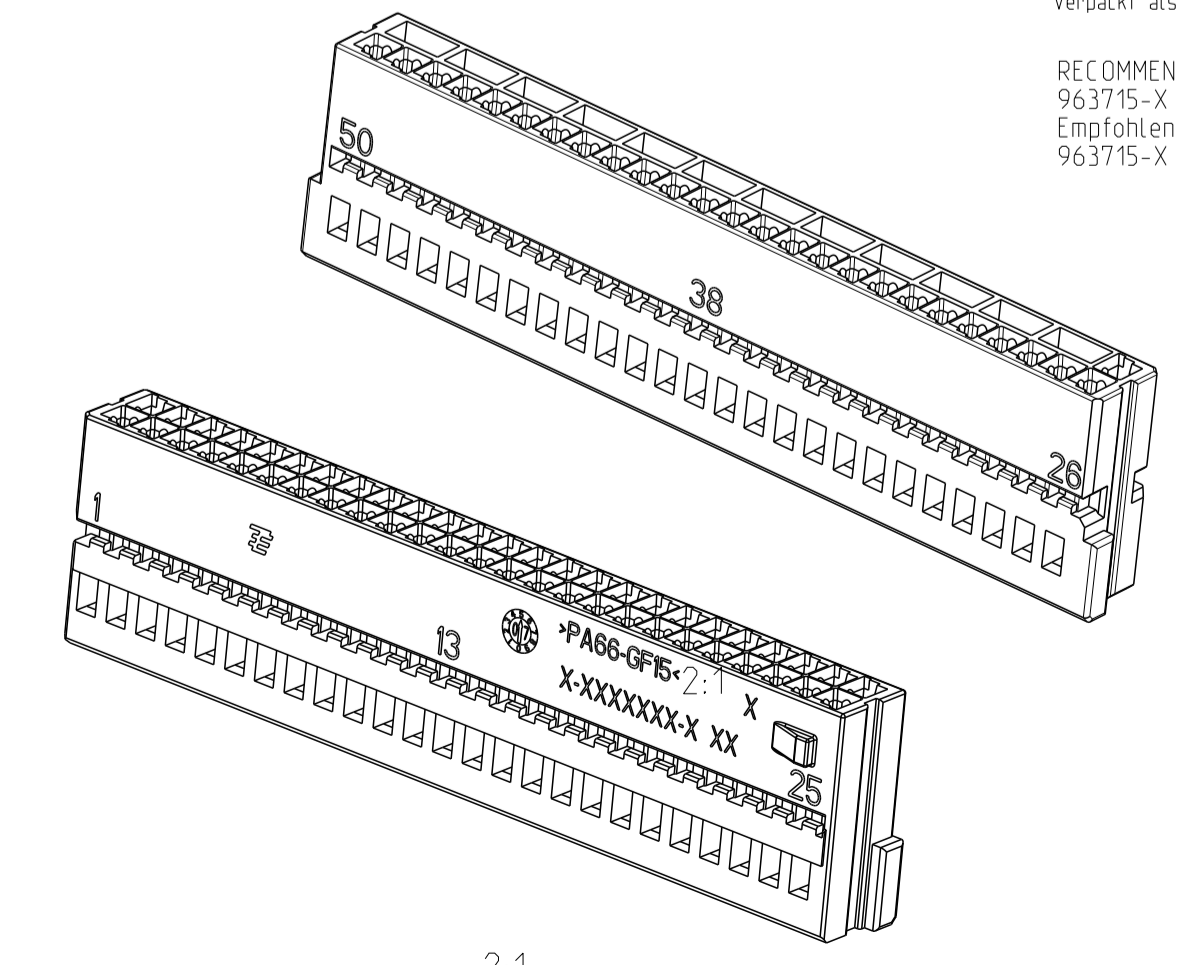
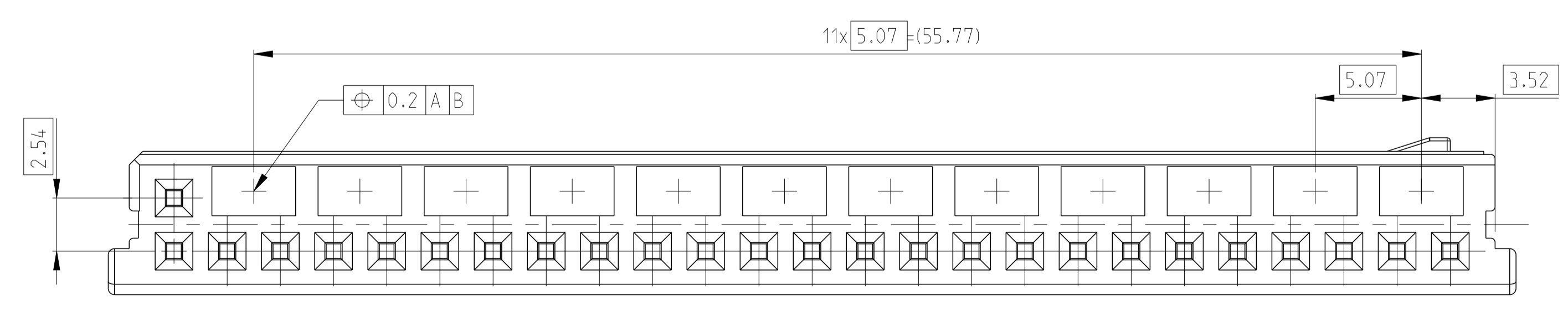

2:1

B1	2208331-3/-4	RIGHT	4-1703941-3	B	Grey	4
	2208331-3/-4	RIGHT	4-1703941-2	B	Grey	4
B1	2208331-1/-2	LEFT	4-1703941-1	B	Grey	4
	3-1703938-1	RIGHT	3-1703941-1	B	Black	4
	2-1703938-1	LEFT	2-1703941-1	B	Blue	4
B1	1-1703938-1	LEFT	1-1703941-1	B	Black	4
	2208331-1/-2	LEFT	1-1703941-1	B	Black	4

1- -1 AS SHOWN  
 Wie gezeigt

DIMENSIONS:		TOLERANCES UNLESS OTHERWISE SPECIFIED:		MATERIAL:		FINISH:		APVD		NAME		DATE		DRAWING NO.		RESTRICTED TO					
mm		0 PLC	±0.3	1 PLC	±0.3	2 PLC	±0.3	3 PLC	±0.3	4 PLC	±0.3	ANGLES	±0.2°	WEIGHT		SCALE	SHEET	OF	REV		
MATERIAL: PA66-GF15		FINISH: -		WEIGHT: -		APVD: -		NAME: -		DATE: 14DEC2007		DRAWING NO: 00779		RESTRICTED TO: -		SCALE: 5:1		SHEET 1 OF 1		REV B1	