

4

3

2

1

THIS DRAWING IS UNPUBLISHED. RELEASED FOR PUBLICATION
 © COPYRIGHT - By - ALL RIGHTS RESERVED.

REVISIONS				
P	LTR	DESCRIPTION	DATE	APVD
	A4	REVISED PER ECO-11-005027	12MAR11	RK HMR
	A5	REVISED PER ECO-17-008114	01JUN2018	RS DR

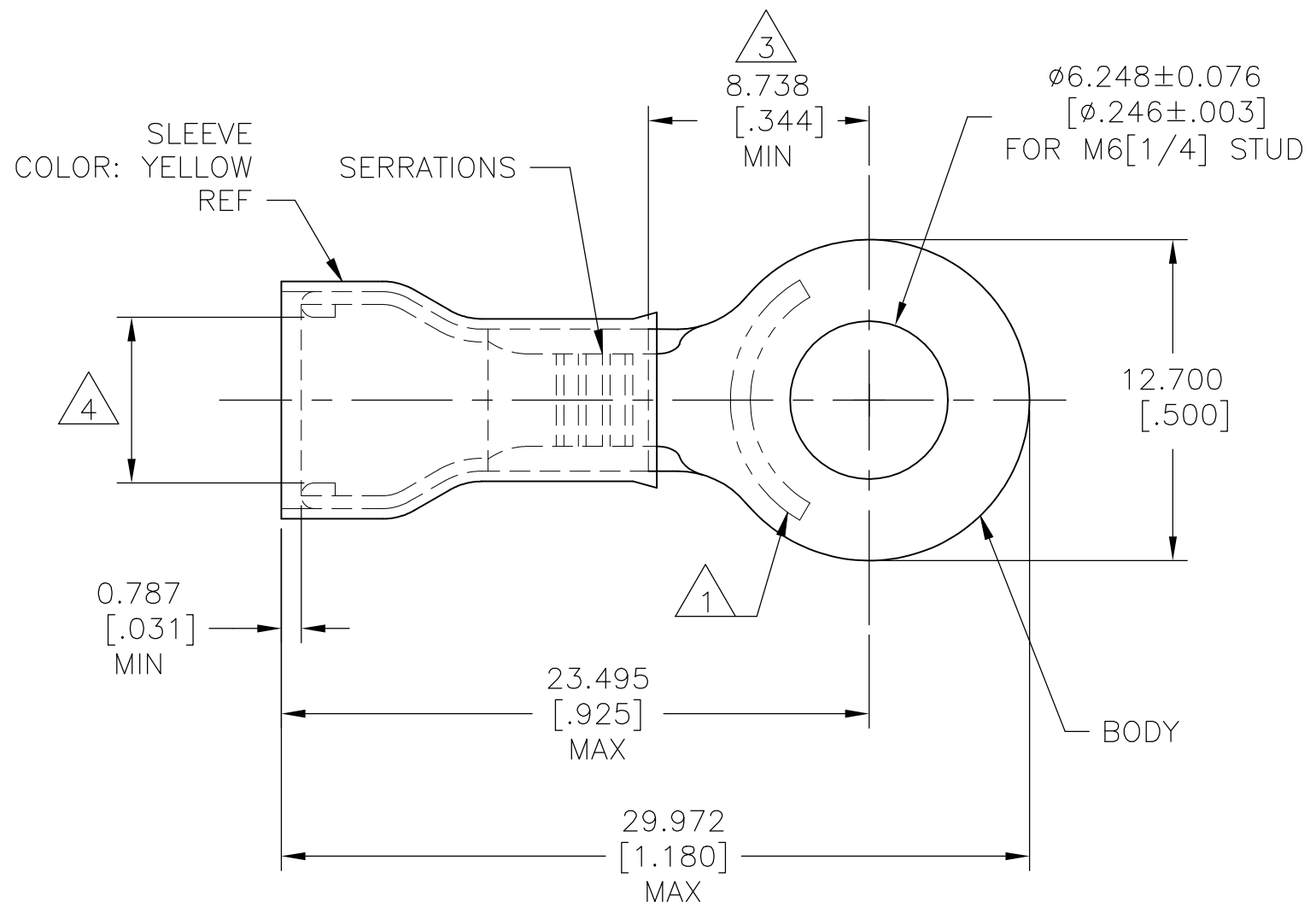

- 1 STAMP "AMP 12-10*", LOCATION APPROX AS SHOWN
- 2 BODY MATERIAL THICKNESS IS 0.991±0.051[.039±.002]
- 3 APPLIES TO EDGE OF METAL WIRE BARREL TO CENTER OF STUD HOLE
- 4 WIRE INSULATION DIA RANGE 3.810-6.426[.150-.253]
- 5 BODY - COPPER PER ASTM B152 SLEEVE - COPPER PER ASTM B152 INSULATION - NYLON
- 6 BODY - TIN PLATE PER ASTM B545 SLEEVE - TIN PLATE PER ASTM B545 INSULATION - COLOR-YELLOW
- 7 105°C MAX OPERATING TEMP
- 8 300 VOLT MAX
- 9 2.62-6.64mm² [5,180-13,100 CMA] SOLID OR STRANDED

500	LOOSE PIECE	165028
QTY	PACKAGE TYPE	PART NO

THIS DRAWING IS A CONTROLLED DOCUMENT.		DWN jr ruth 29MAR07	TE Connectivity Ltd.	
DIMENSIONS: mm [INCHES]		CHK T MICHIELUTTI 29MAR07		
TOLERANCES UNLESS OTHERWISE SPECIFIED:		APVD T MICHIELUTTI 29MAR07	NAME TERMINAL RING TONGUE, PIDG, WIRE SIZE 12-10	
0 PLC ± - 1 PLC ± - 2 PLC ± - 3 PLC ± 0.127[.005] 4 PLC ± - ANGLES ± 5°		PRODUCT SPEC UL 486 A-B	RESTRICTED TO	
MATERIAL		APPLICATION SPEC 114-2157	SIZE A3	CAGE CODE 00779
FINISH		WEIGHT	DRAWING NO 165028	REV A5
5		CUSTOMER DRAWING		SCALE 4:1
6		SHEET 1 OF 1		