

4

3

2

1

THIS DRAWING IS UNPUBLISHED. RELEASED FOR PUBLICATION 20
 © COPYRIGHT 20 BY TYCO ELECTRONICS CORPORATION. ALL INTERNATIONAL RIGHTS RESERVED.

LOC	DIST	REVISIONS					
AP	-	P	LTR	DESCRIPTION	DATE	DWN	APVD
			A	RELEASED RSA-10-091-01	10SEP2010	NCL	DAO
			AI	REVISED BY ECO-10-023502	17NOV2010	NCL	ASV

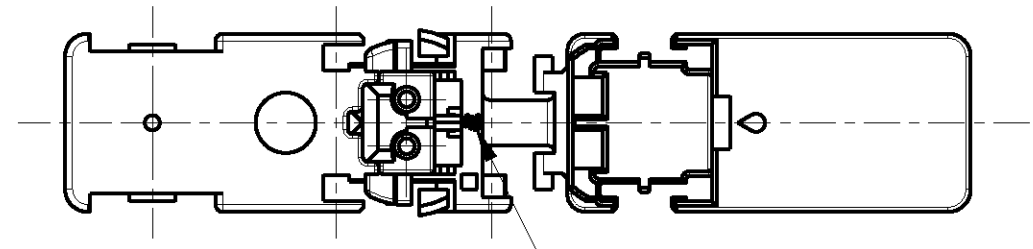
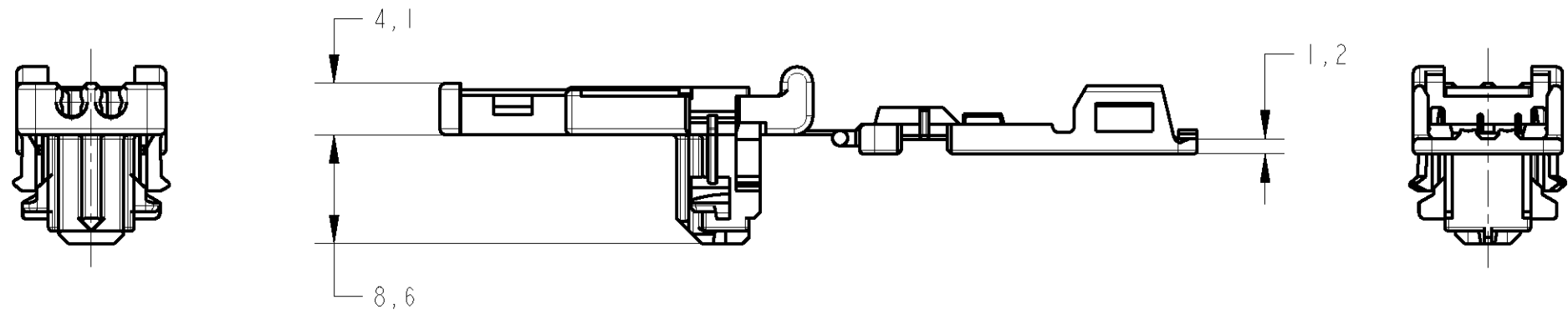
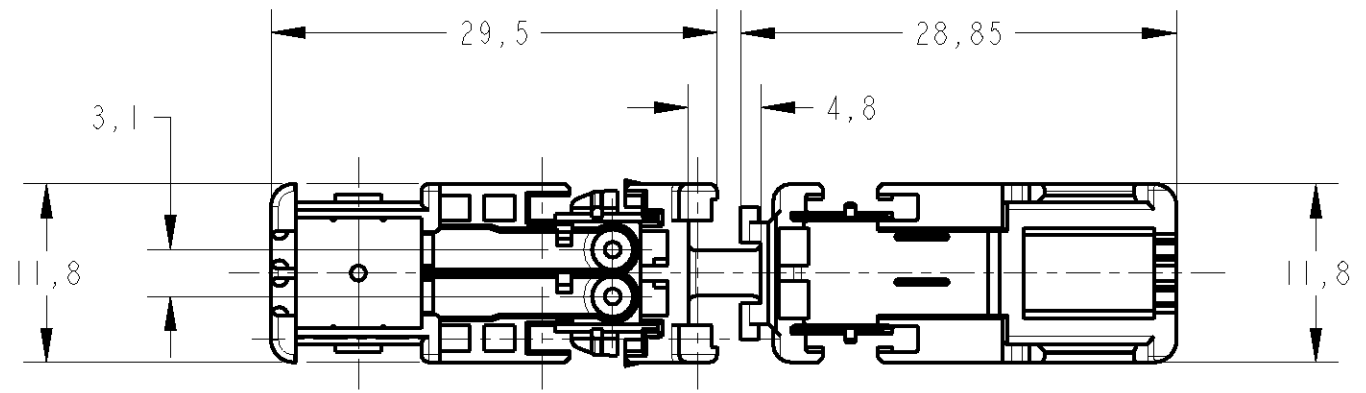

- 1- TERMINAL APLICÁVEL NÚMERO: 353376
(BITOLA DO CABO: AVSS,CAVS 0,3~0,5mm²)
FERRITE APLICÁVEL NÚMERO: 353379.
 - 2- ESTE PRODUTO DEVE SER UTILIZADO COM O 11 DIA SQUIB MK-2 SLIM PLUG HSG TRAVAMENTO INFERIOR (NÚMERO 1612119).
 - 3- MONTAR ANEL CURTO-CIRCUITO NÚMERO DA PEÇA: 699638,1376766,1473369.
 - 4- FORMA DE INTERFACE VER O DESENHO DO ANEL DE CURTO-CIRCUITO.
 - 5- FOLHA DE INSTRUÇÃO: 411-78040.
- 1- APPLICABLE TERMINAL P/N: 353376
(WIRE RANGE: AVSS,CAVS 0,3~0,5mm²)
APPLICABLE FERRITE P/N: 353379.
 - 2- THIS PRODUCT SHOULD BE USED WITH THE 11 DIA SQUIB SLIM MK-2 PLUG HSG LOCKING BUTTON (P/N: 1612119).
 - 3- MATING SHORT-CIRCUIT RING PART NUMBER: 699638, 1376766, 1473369.
 - 4- ABOUT THE FORM OF INTERFACE, SEE THE DRAWING OF SHORT-CIRCUIT RING.
 - 5- INSTRUCTION SHEET: 411-78040.

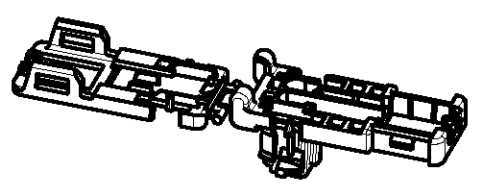

PERSPECTIVE VIEW
SCALE 1:1

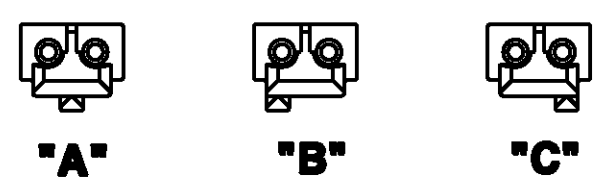

POSIÇÃO RIB
RIB POSITION

THIS DRAWING IS A CONTROLLED DOCUMENT FOR TYCO ELECTRONICS CORPORATION IT IS SUBJECT TO CHANGE AND THE CONTROLLING ENGINEERING ORGANIZATION SHOULD BE CONTACTED FOR THE LATEST REVISION.

DIMENSIONS:	TOLERANCES UNLESS OTHERWISE SPECIFIED:
mm	0 PLC ±-
	1 PLC ±0,2
	2 PLC ±-
	3 PLC ±-
	4 PLC ±-
	ANGLES ±°
MATERIAL SEE TABLE	FINISH SEE TABLE

AMARELO/YELLOW	C	TRIBIT 1503(K)	1612120 -4
FINISH	RIB POS	MATERIAL	PART NUMBER
DWN NCLAPRESA 10SEP2010	TYCO ELECTRONICS Brasil LTDA. Sao Paulo, Brasil		
CHK JRGOLDSCHMIDT 10SEP2010	NAME 11 DIA SQUIB SLIM MK-2 PLUG HSG		
APVD DAOLIVEIRA 10SEP2010	-		
PRODUCT SPEC -	SIZE A3	CAGE CODE 00779	DRAWING NO C-1612120-4
APPLICATION SPEC -	RESTRICTED TO -		SCALE 3:1
WEIGHT -	CUSTOMER DRAWING		SHEET 1 OF 1 REV AI