

LOC AP DIST -

REVISIONS

P	LTR	DESCRIPTION	DATE	DWN	APVD
	I	RELEASED LE10-0300/04	30SEP2004	H.C	WLS
	A	REVISED PER ECR-23-181973	24JUL2023	PC	TD

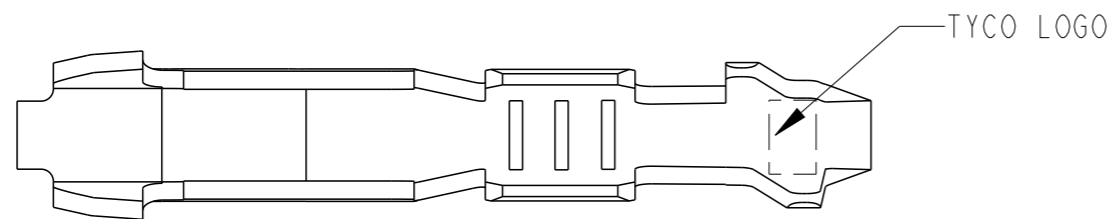

1- FITA CONTINUA EM BOBINA.
CONTINUOUS STRIP ON REEL.

2- INSERTION FORCE 60N
EXTRACTION FORCE 12N
PER CONTACT WHEN USED 2,285mm ±0,002 DIA PIN GAGE 0,2RA.

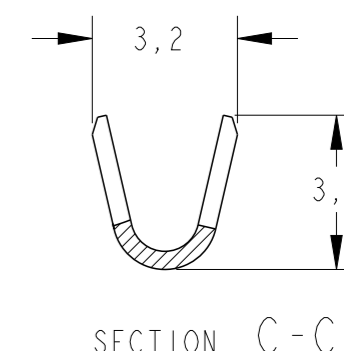
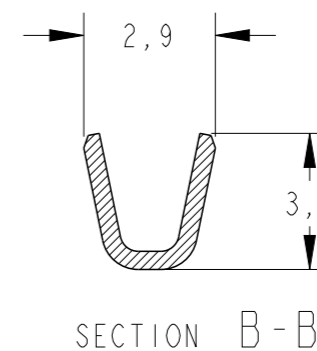
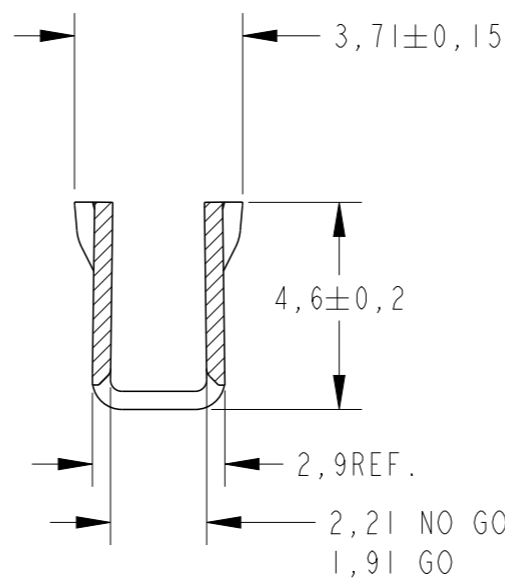
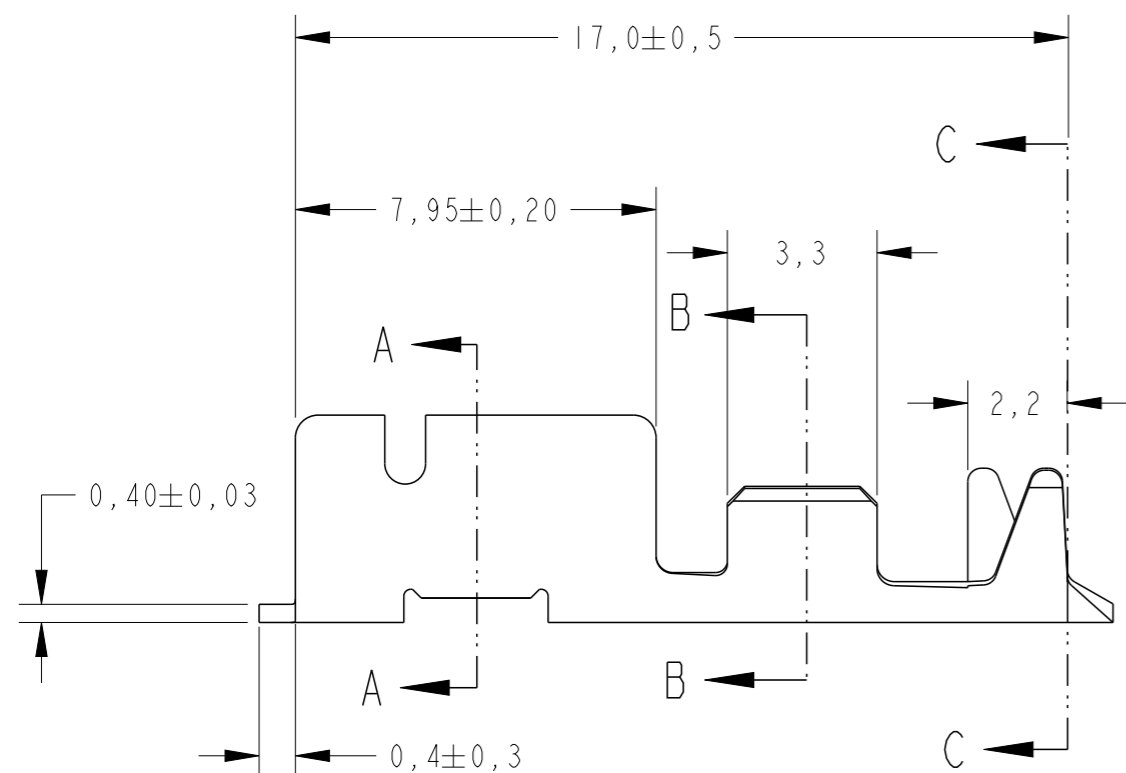

SECTION A-A

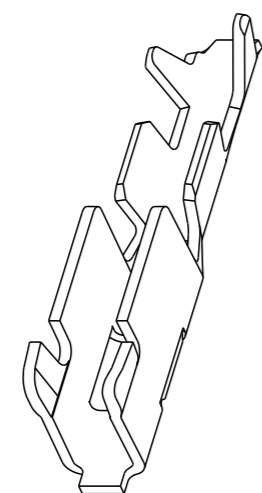

SCALE 4:1

∅ 1,2/2,0mm	0,5/0,75mm ²	NÚ/NONE	PH BRONZE T3	1599107-1
INSULATION RANGE	WIRE RANGE	FINISH	MATERIAL	PART NUMBER

THIS DRAWING IS A CONTROLLED DOCUMENT.		DWN H.C.CANTERI 04jun2003	STE TE Connectivity			
DIMENSIONS: mm		CHK -				
TOLERANCES UNLESS OTHERWISE SPECIFIED:		APVD -	NAME RECEPTACLE, CLUSTER PIN, 2.29 (.090) DIA.			
0 PLC ±-		PRODUCT SPEC -				
1 PLC ±0,30		APPLICATION SPEC -	SIZE A3	CAGE CODE 00779	DRAWING NO C=1599107	RESTRICTED TO -
2 PLC ±0,25		WEIGHT -	SCALE 6/1		SHEET 1 OF 1	REV A
3 PLC ±-		Customer Drawing				
4 PLC ±-						
ANGLES ±-						
FINISH -						