



All numerical values are in metric units [with U.S. customary units in brackets]. Dimensions are in millimeters [and inches]. PC board layouts are in inches only. Unless otherwise specified, dimensions have a tolerance of  $\pm 0.13$  [ $\pm .005$ ] and angles have a tolerance of  $\pm 2^\circ$ . Figures and illustrations are for identification only and are not drawn to scale.

## 1. INTRODUCTION

This specification covers the requirements for application of CHAMP pc board mounted connectors. The connectors are available in shielded and unshielded versions and are designed for right-angle-, vertical-, and edge-mount applications. The illustrations represent the available mounting options and show unshielded connectors for simplicity (plug and receptacle, shielded and unshielded are essentially the same).

When corresponding with TE Connectivity Personnel, use the terminology provided in this specification to facilitate your inquiries for information. Basic terms and features of this product are provided in Figure 1.

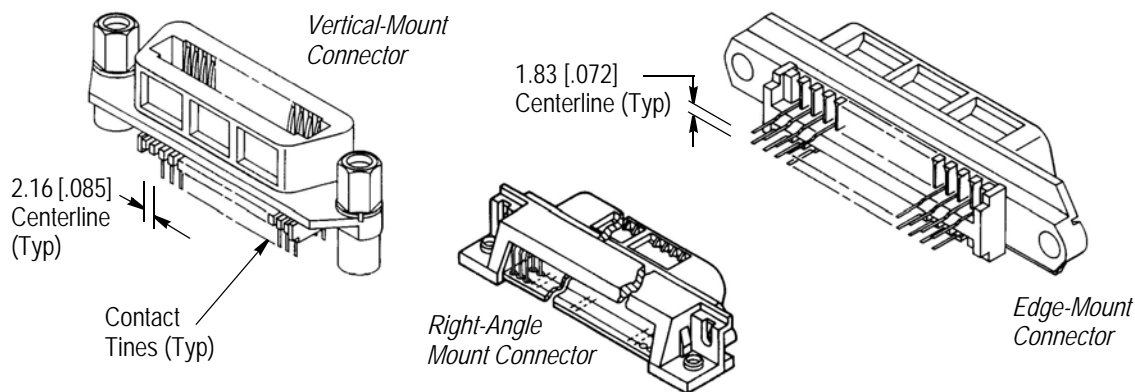

Figure 1

## 2. REFERENCE MATERIAL

### 2.1. Revision Summary

- Updated document to corporate requirements
- New logo

### 2.2. Customer Assistance

Reference Product Base Part Number 552725 and Product Code 1252 are representative of the CHAMP pc board connector product line. Use of these numbers will identify the product line and expedite your inquiries through a service network established to help you obtain product and tooling information. Such information can be obtained through a local Representative or, after purchase, by calling PRODUCT INFORMATION at the number at the bottom of this page.

### 2.3. Drawings

Customer Drawings for product part numbers are available from the service network. If there is a conflict between the information contained in the Customer Drawings and this specification or with any other technical documentation supplied, the information contained in the Customer Drawings takes priority.

### 2.4. Specification

Product Specification 108-6078 provides product performance and test information.

### 2.5. Manuals

Manual 402-40 is available from the service network. This manual provides information on various flux types and characteristics along with the commercial designation and flux removal procedures. A checklist is included to the manual as a guide for information on soldering problems.

## 2.6. Instructional Material

Instruction Sheet 408-7672 provides right-angle and vertical-mount connector installation procedures. Instruction Sheet 408-3201 provides edge-mount connector installation procedures. Instruction Sheet 408-3160 provides attachment hardware information. Instruction Sheet 408-7564 provides mating cable connector information.

## 3. REQUIREMENTS

### 3.1. Safety

Do not stack product shipping containers so high that the containers buckle or deform.

### 3.2. Storage

#### A. Shelf Life

The connectors should remain in the shipping containers until ready for use to prevent deformation to the contacts. The connectors should be used on a first in, first out basis to avoid storage contamination that could adversely affect performance.

#### B. Chemical Exposure

Do not store connectors near any chemical listed below as they may cause stress corrosion cracking in the contacts.

Alkalies	Ammonia	Citrates	Phosphates	Citrates	Sulfur Compounds
Amines	Carbonates	Nitrites	Sulfur Nitrites		Tartrates

### 3.3. Printed Circuit Board

#### A. Material

The board should be composed of glass/epoxy material, use of less dimensionally stable material may present problems when inserting the components.

#### B. Thickness

The connectors may be installed on 1.57 to 3.18 mm [.062 to .125 in.] thick pc boards for vertical- and right-angle mount connectors and on 1.57 mm [.062 in.] thick PC Boards for edge-mount connectors. PC board thickness may vary depending upon application, however, terminal length becomes important for wave solder operations. A recommended minimum of 1.02 mm [.040 in.] terminal should protrude through the pc board. PC boards are divided into three categories, Class A, Class B, and Class C, depending on hole location tolerances (see Figure 2).

HOLE LOCATION TOLERANCES mm [in.]			
RELATED BOARD SIZE	CLASS A	CLASS B	CLASS C
Greatest Dimension is Less Than 304.8 [12.00]	±0.20 [.008]	±0.10 [.004]	±0.05 [.002]
Greatest Dimension is Greater Than 304.8 [12.00]	±0.20 [.008]	±0.15 [.006]	±0.10 [.004]

Figure 2

#### C. PC Board Layout

Typical pc board layouts are provided in Figure 3.

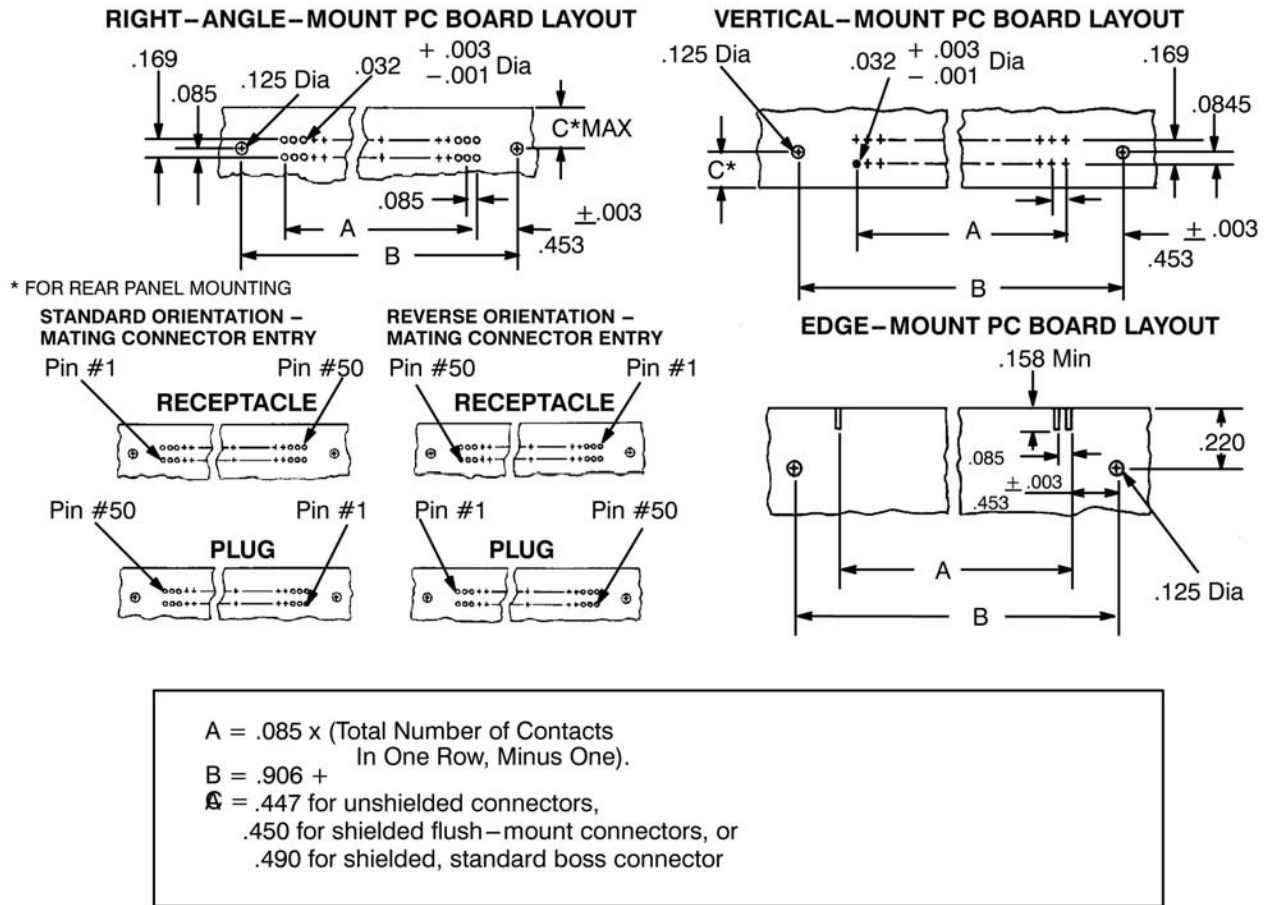

Figure 3

### 3.4. Mating Dimensions

The dimension in Figure 4 is required to assure full mating of connectors. This dimension must be considered when determining the method of mounting and the thickness of a panel when the connector is to be panel mounted.

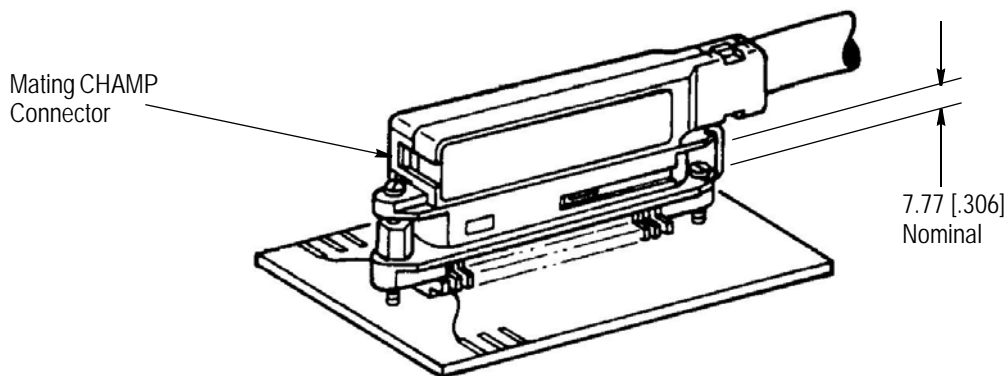
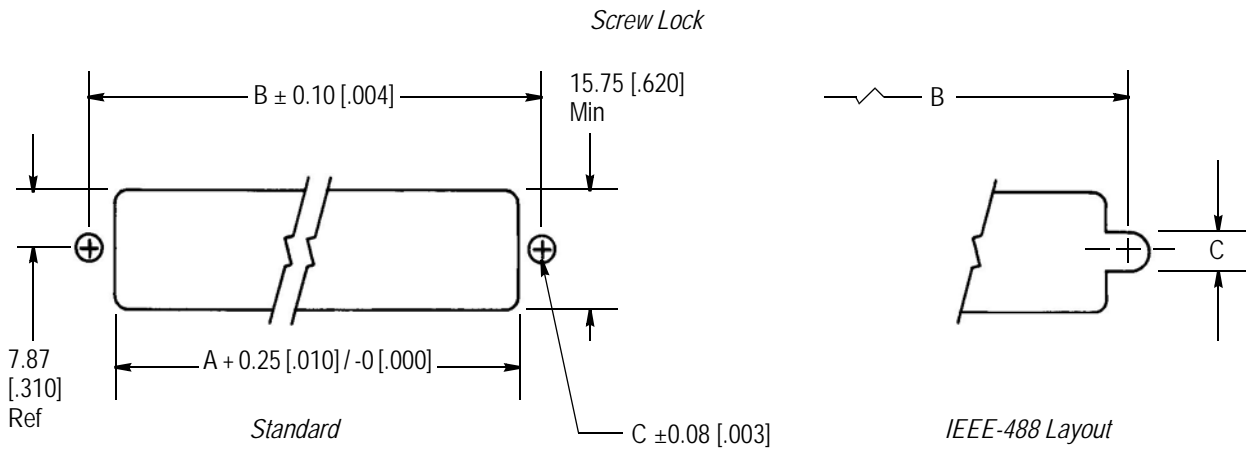

Figure 4

### 3.5. Panel Mounting

The layout in Figure 5 provides the dimensions required for rear panel mounting the shielded and unshielded connectors.



SCREW LOCK						BAIL LOCK			
NO. OF POSITIONS		DIMENSIONS				NO. OF POSITIONS		DIMENSIONS	
SHIELDED	UNSHIELDED	A	B	C		SHIELDED	UNSHIELDED	A	B
				SHIELDED	UNSHIELDED				
---	14	29.26 [1.152]	35.97 [1.416]	---	3.20 [.126]	---	14	35.05 [1.380]	35.97 [1.416]
24	24	40.00 [1.575]	46.79 [1.842]	†	3.20 [.126]	24	24	45.87 [1.806]	46.79 [1.842]
36	36	52.96 [2.085]	59.74 [2.352]	3.78 [.149]	3.20 [.126]	36	36	58.83 [2.316]	59.74 [2.352]
50	50	68.58 [2.700]	74.83 [2.946]	3.78 [.149]	3.20 [.126]	50	50	73.91 [2.910]	74.83 [2.946]
---	64	83.18 [3.275]	89.97 [3.542]	---	3.20 [.126]	---	64	89.05 [3.506]	89.97 [3.542]

Panel thickness range: 1.57 mm [.062 in.] for rear panel mount applications. For 24-position IEEE-488 metric version 1.57-2.36 mm [.062-.093 in.] may be used. †3.86 mm [.152 in.] for standard hardware; 4.88 mm [.192 in.] for metric hardware.

Figure 5

### 3.6. Polarization

By its very design, the connector is polarized. The keystone configuration of the mating face prohibits the accidental inversion of a mating connector.

### 3.7. Methods of Attaching Connector to PC Board

The connector should be secured to the PC Board prior to soldering. This can be done by using any of the following methods:

#### A. Commercially Available Hardware

Most connectors are to be attached to the pc board with commercially available screws, washers, and nuts, rivets, or similar devices. The hardware should be attached prior to soldering and soldered in place when the solder posts are soldered.

#### B. Boardlocks

Some connectors include boardlock features that contain two gripping shoulders which lock into position as the solder posts are inserted into the pc board. See Figure 6

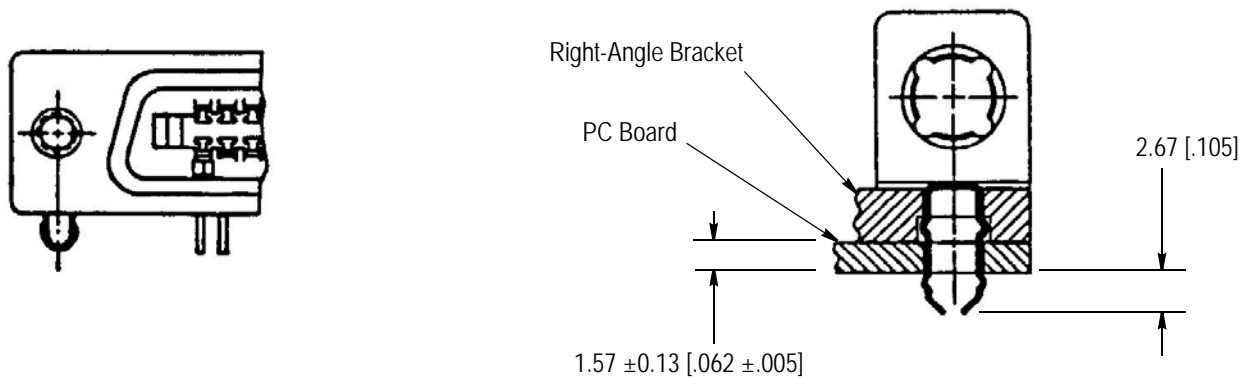

Figure 6

### 3.8. Fastening Hardware

Hardware such as screwlock kits, bail lock kits, and CHAMP-LOK\* kits are available to secure mated unshielded connectors. Shielded connectors are available in kit form and will accept standard fastening hardware or the connectors are available in preassembled form with fastening hardware also preassembled. See Figure 7.

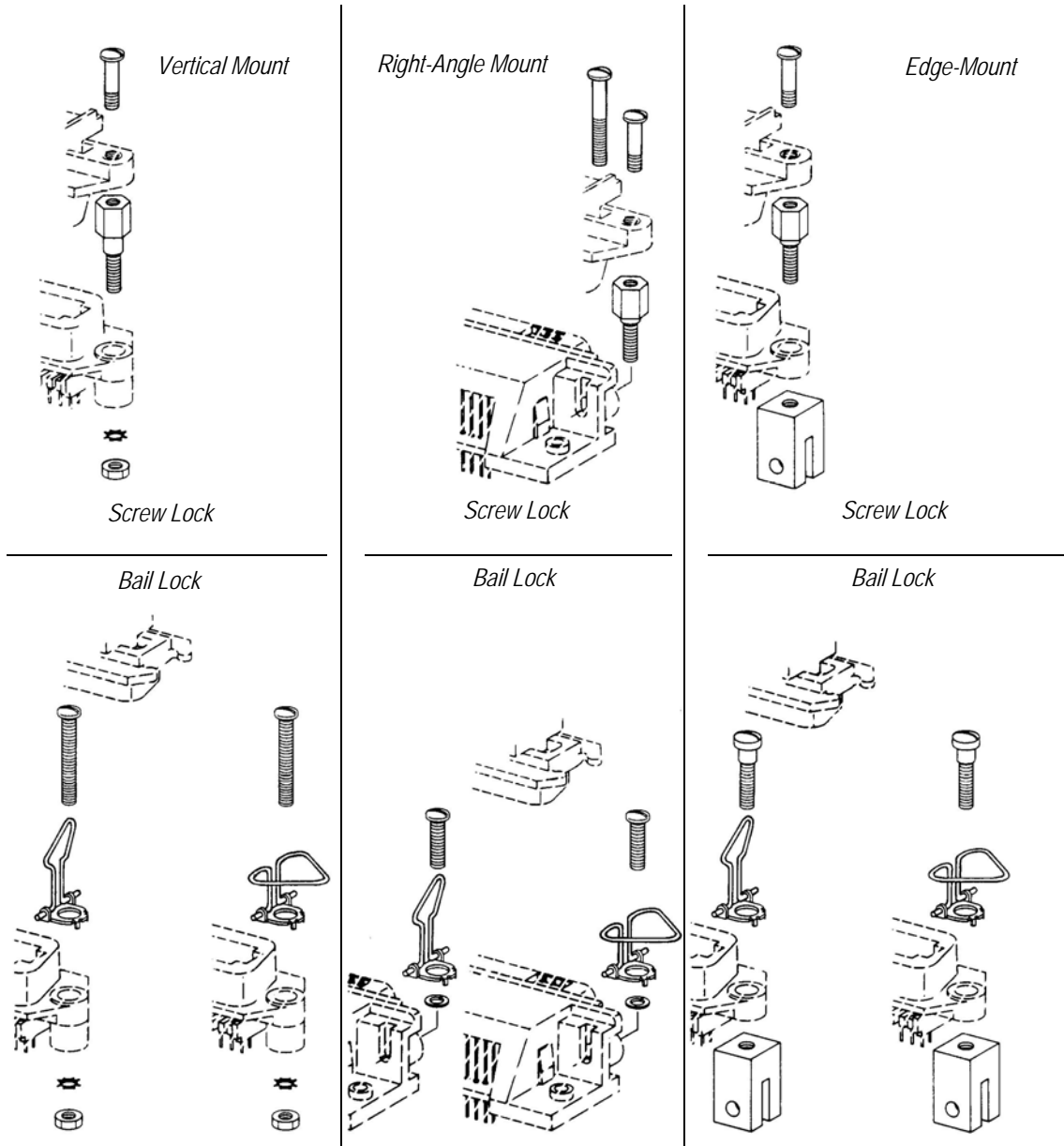

Figure 7

### 3.9. Ancillary Items

Dust covers are available to protect the mating face of connectors that are NOT mated.

### 3.10. Soldering

#### A. Flux Selection

The connector solder tails and attaching hardware (if applicable) must be fluxed prior to soldering with a medium active rosin base flux or a medium to highly active organic flux. Selection of the proper flux will depend on the type of PC Board and other components, if any, mounted on the board. Additionally, the choice of flux will have to be compatible with the flow solder line, manufacturing, and safety requirements.

#### B. Cleaning

Removal of fluxes, residues, and activators is mandatory. Cleaning procedures are dependent upon the type of flux used on the solder line.

### C. Drying

When drying cleaned assemblies and PC Boards make certain that temperature limitations of -55° to 105°C [-67° to 221°F] are not exceeded. Excessive temperatures may cause housing degradation.

### D. Soldering Guidelines

Manual 402-40 is available upon request and can be used as a guide in soldering. This manual provides information on various flux types and characteristics along with the commercial designation and flux removal procedures. A checklist is included in the manual which is intended to serve as a guide for obtaining information on soldering problems.

### 3.11. Special Filter Connector

This receptacle connector filters out unwanted frequencies by capacitive parallel circuits to ground. See Figure 8.

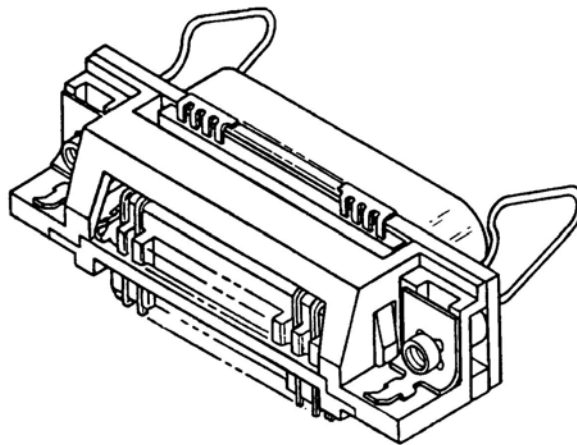

Figure 8

## 4. QUALIFICATIONS

No qualifying support was provided at the time of publication.

## 5. TOOLING

No special tooling is required for this product line.

## 6. VISUAL AID

The illustration below shows a typical application of this product. This illustration should be used by production personnel to ensure a correctly applied product. Applications which DO NOT appear correct should be inspected using the information in the preceding pages of this specification and in the instructional material shipped with the product or tooling.

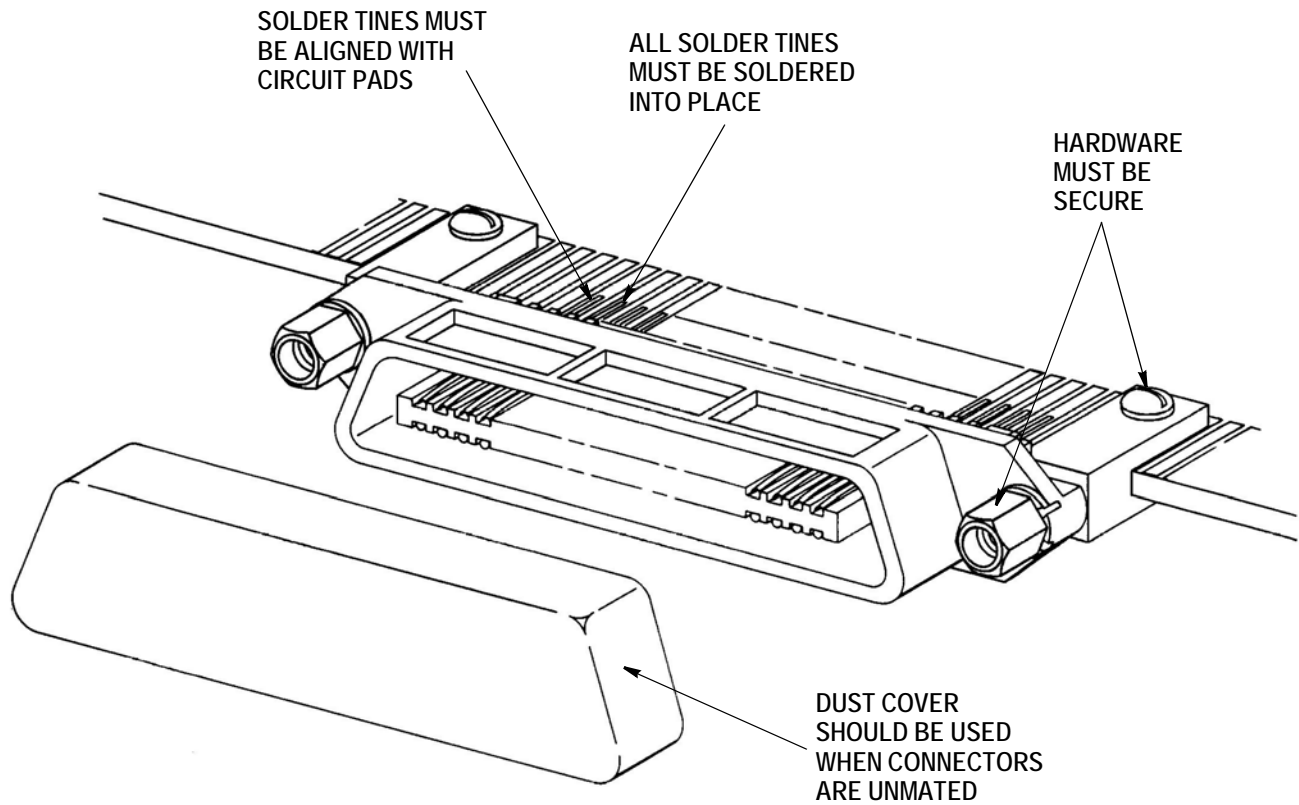

**FIGURE 9. VISUAL AID**