



NOTE

All numerical values are in metric units [with U.S. customary units in brackets]. Dimensions are in millimeters. Unless otherwise specified, dimensions have a tolerance of ± 0.13 mm and angles have a tolerance of $\pm 2^\circ$. Figures and illustrations are for identification only and are not drawn to scale.

1. INTRODUCTION

This specification covers the requirements for application of SOLARLOK PV Edge Solar Junction Box onto a photovoltaic (PV) solar panel. Each junction box consists of a base (with or without edge guides/flap tracks), lid, plug connector cable assembly and socket connector cable assembly or no connector cable assembly for connectorized versions.

The base features two open areas, two contact rails, and one diode. Each contact rail provides interface tabs for terminating the PV panel's foil tabs. The open areas allow PV panel's foil tabs to reach the interface tabs while maintaining a seal between the junction box and solar panel. Each diode features two legs that support it in place on the contact rails. The back of the base features an attachment area used in mounting the junction box onto the solar panel. A silicon sealant is applied around the perimeter of the attachment area to secure and seal the base to the PV panel. Boxes with the flap track feature use an Edge Flap to seal the edge of the Glass-Glass type PV panel where the foil tabs exit between the panes of glass.

When corresponding with TE Connectivity Personnel, use the terminology provided in this specification to facilitate your inquiries for information. Basic terms and features of this product are provided in Figure 1.

License holder: Tyco Electronics Austria GmbH, Schrackstrasse 1, 3830 Waidhofen/Thaya, Austria.

Glass-Glass Edge Mount Application

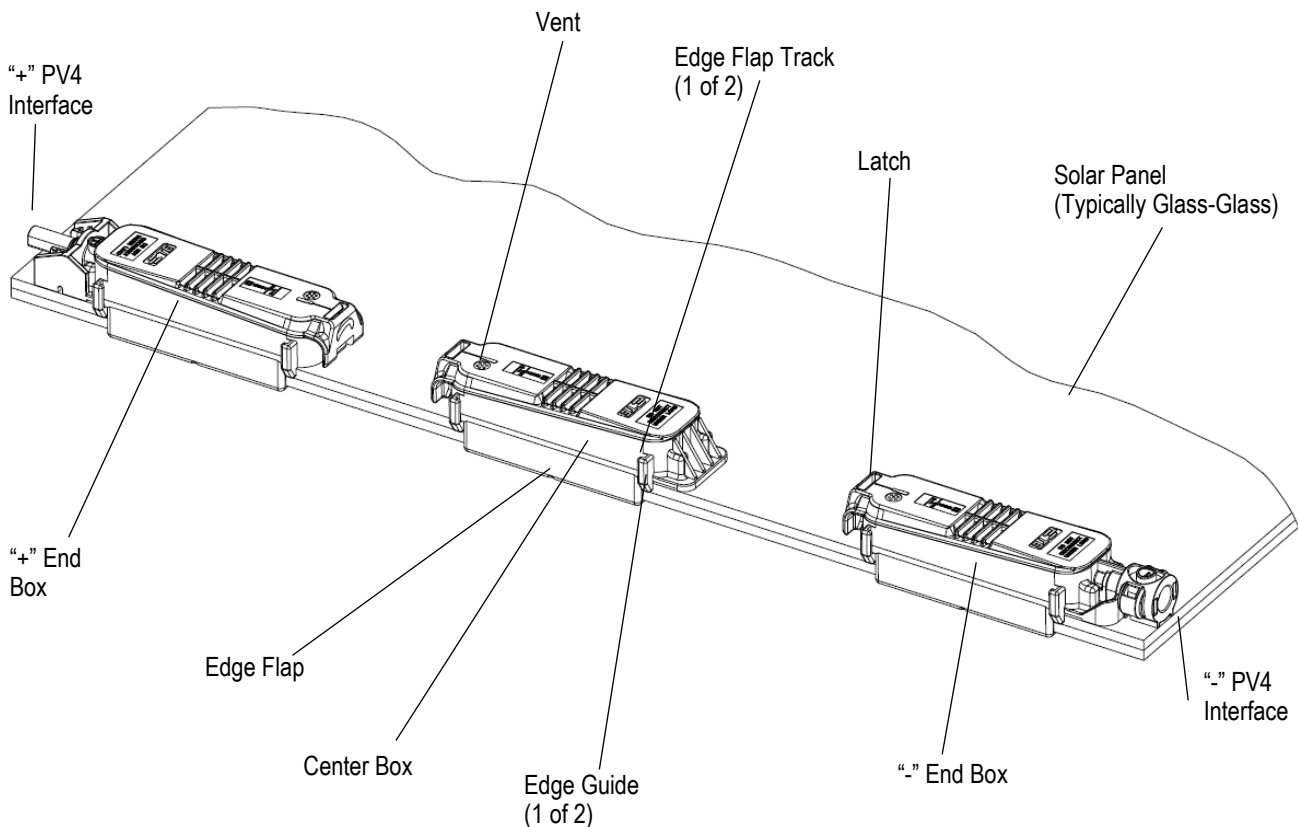

Figure 1 (cont'd)

Traditional Mid-Panel Application

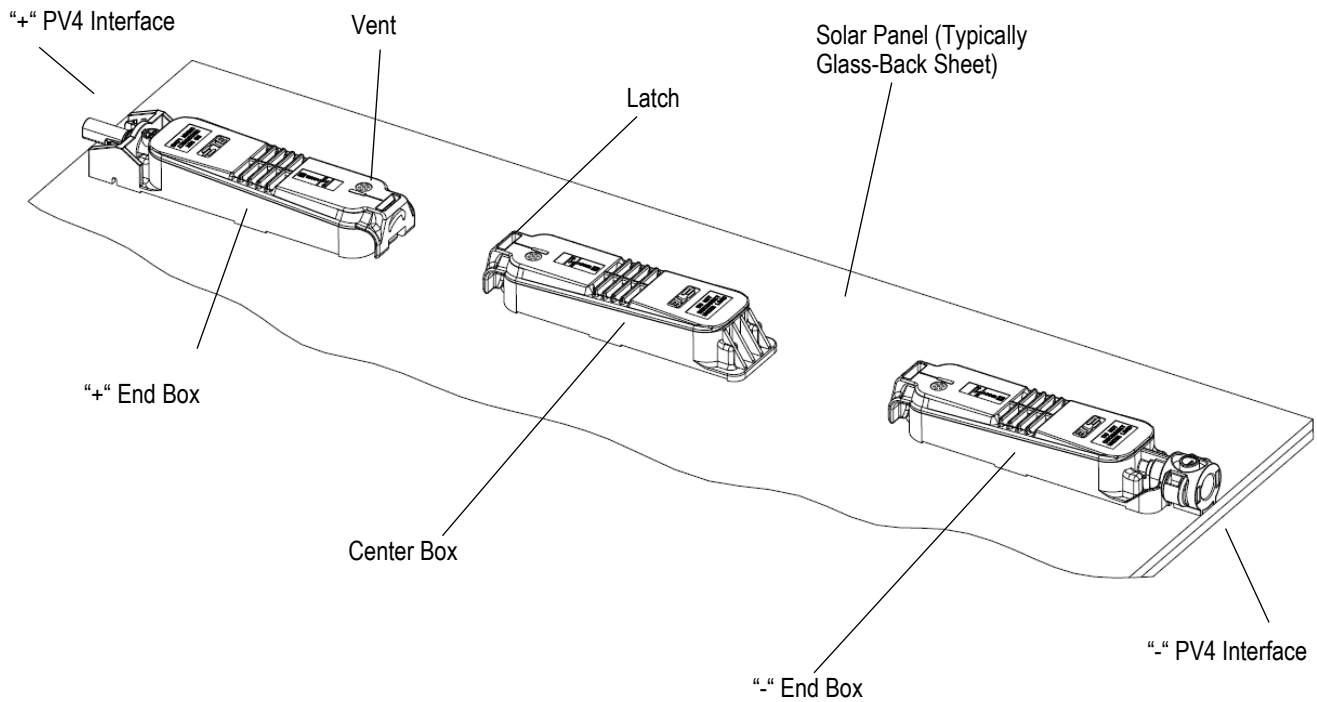

Figure 1 (end)

The lid features an O-ring that, when the lid is closed, ensures a tight seal. The lid has attachment tabs and a latch. The latch ensures that the lid is locked and requires a bladed instrument (such as a flat-blade screwdriver) to release the latch.



NOTE

The application of the TE SOLARLOK PV Edge Solar Junction Box on the solar panel as well as the installation of the solar panel is not part of the scope of services offered by TE. In addition, TE does not offer a warranty for the SOLARLOK PV Edge Solar Junction Box with integrated solar cable assemblies if those cable assemblies will be exchanged or unfixed after delivery from TE. A cable extension has to be made at the coupling end of the cable (plug connector) and only with TE components. If single connectors without attached cable are delivered by TE, the mounting of the cable is also not in the scope of services offered by TE. This is also the case for subsequent mounting or replacing diodes.

2. REFERENCE MATERIAL

2.1. Revision Summary

- New information on Figure 7 and Figure 9a and 9b. Additional general clarifications.

2.2. Customer Assistance

Reference Product Base Part Numbers 2306314 (Flap, S clip), 2306315 (No Flap, S Clip), 2306316 (Flap Ω Clip), 2306317 (No Flap Ω Clip), 2306318 (Flap Weld), 2306319 (No Flap Weld), 2307520 (Large Flap, S Clip), 2307521 (Large Flap Ω Clip), 2307522 (Large Flap Weld) and Product Code 4013 are representative of the SOLARLOK PV Edge Solar Junction Box. Use of these numbers will identify the product line and help you to obtain product and tooling information when visiting www.te.com or calling the PRODUCT INFORMATION number at the bottom of page 1.

2.3. Drawings

Customer drawings for product part numbers are available from www.te.com. Information contained in the customer drawing takes priority.

2.4. Specifications

Product Specification [108-32122](#) provides approved product performance and test results for the SOLARLOK PV Edge Solar Junction Box. Application Specification [114-137077](#) provides product description and application requirements for PV4-S1YX cables and connectors used with the junction box.

2.5. TÜV Rheinland approved components

- Adhesive for JB/ backsheet Dow Corning PV-804 (black or white)
- Bypass Diode TE 2213713-1
- Thermal Interface Material TE 2213728-1
- Back sheet
voltage of 1000 V dc) Krempel AKALIGHT CMF 377 (maximum rated system
- Back sheet Dunmore DS-375
- Back sheet Dunmore DS-475
- Back sheet
dc) Dunmore DS-450 (maximum rated system voltage of 1000 V

3. REQUIREMENTS

3.1. Safety

- Appropriate gloves and eye protection must be used throughout the entire installation of the junction box.
- Adequate ventilation must be ensured at all times during the installation of the junction box.
- Eating, drinking, and smoking must not be allowed in the vicinity when installing or working with the junction box.
- DO NOT expose the junction box to open flames.

3.2. Limitations

The junction box location and the installation and assembly procedures for the junction box, connectors, and cable assemblies must agree with the ESD items.

- Equip floor and workstation with ESD materials
- Equip work tables by safety wrist and ankle straps.
- Equip ESD shoes for every worker.
- ESD tester in front of operation room door. Everyone who enters workshop should pass the ESD test.
- Equip heel strip for visitors who do not wear ESD shoes.
- Equip a tester to verify if wrist and ankle straps are well-grounded (every shift).

3.3. Storage

Product shipping containers must not be stacked so high that the containers buckle or deform. The product should remain in the shipping containers until ready for use to prevent deformation to components. Junction boxes, cable assemblies, and connectors must be stored in a clean, dry location.

3.4. PV Solar Panel

Before installing the junction box onto the solar panel, the following requirements apply:

1. The installation procedure described in this document may be used on either glass or glass with plastic back sheet substrate solar panels.

2. The attachment area (located on the bottom) of the solar panel must be dry, oil-free, fat-free, and free of any dust, and contaminants. The attachment area must be thoroughly cleaned using a soft cloth lightly moistened (for example, by using a dosing unit) with isopropyl alcohol. Auxiliary and other cleaning agents must be tested by the customer and proved suitable for use on the solar panel and junction box before being used.

The attachment must be free of condensation and moisture.

Glass-Glass installation preparation: edge mount, using boxes with edge flap and edge guide features TE base part numbers: 2306314 (Flap, S clip) 2306316 (Flap Ω Clip), 2306318 (Flap Weld), 2307520 (Large Flap, S Clip), 2307521 (Large Flap Ω Clip), 2307522 (Large Flap Weld).

The foil tabs extend from between the layers of glass and must be pre-formed, so they extend perpendicular from the surface of the solar panel (See Figure 2).

Tedlar is a trademark.

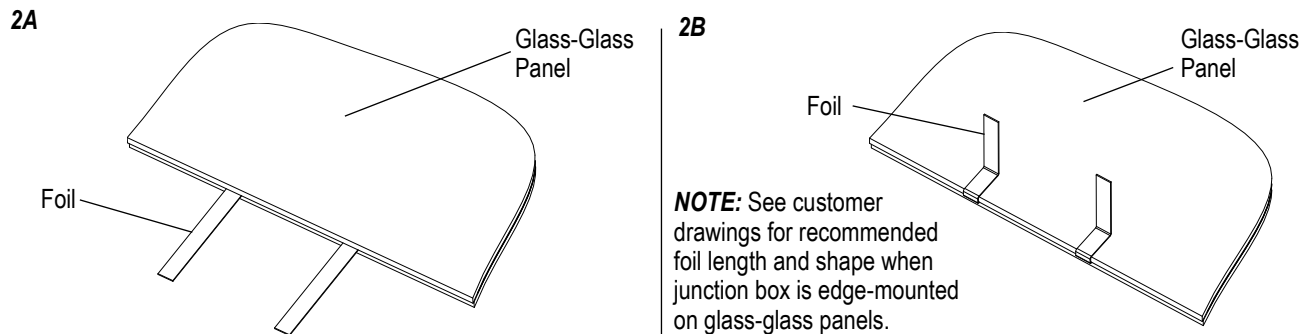
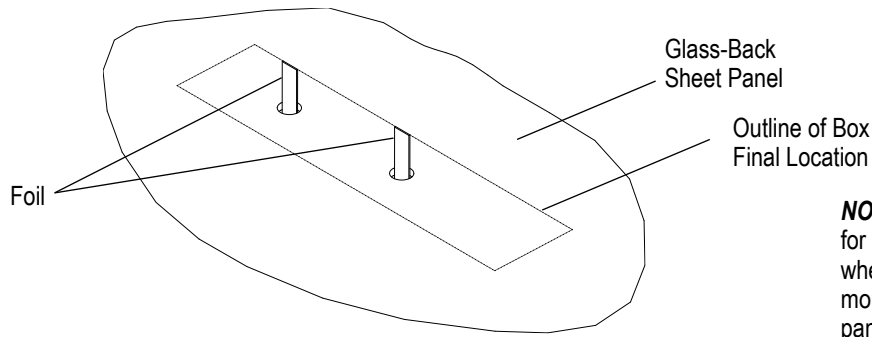

Figure 2

Glass-Back sheet installation preparation: traditional mid-panel mounting, using boxes without the edge flap and edge guide features TE base part numbers: 2306315 (No Flap, S Clip), 2306317 (No Flap Ω Clip), 2306319 (No Flap Weld). Alternate option to use single hole in back sheet or back glass to route both foils through one 15mm diameter hole. See Figure 3.



NOTE: See customer drawings for recommended foil length when junction box is mid-mounted on glass-back sheet panels.

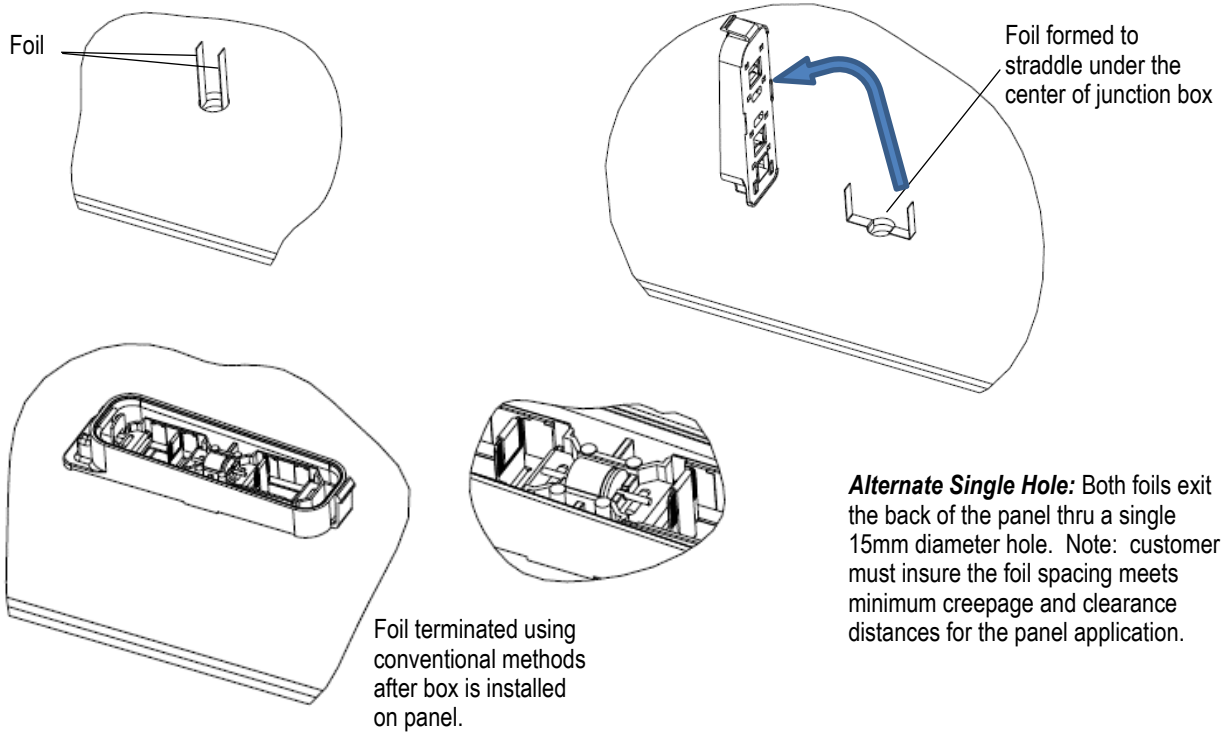

Figure 3

3.5. Connectors

The mating face and seal of each connector interfaced must be protected from contaminants (such as moisture, dust, humidity, environmental pollution, etc.). It is recommended that a suitable dust cover, such as TE part numbers 2232227-1 (socket) and 2213228-1 (pin) be installed onto each unplugged connector. Connectors must be kept clean and dry.



DANGER

To avoid personal injury by electric current, the junction box and connectors must be completely separate from other sources of voltage during installation and assembly. The connectors must not be connected or disconnected when under electrical load.

3.6. Installation

The following installation requirements are intended as a guideline.



NOTE

All tools used for installation are covered in Section 5, TOOLING. Cleaning

Any type of exposure to contaminants (such as moisture, dust, humidity, environmental pollution, etc.) can negatively affect function of the junction box over the duration of use. This especially applies to connector

seals and terminated connections. The environment of the area for installation and assembly must be clean and dry.

In case of contamination, the junction box, cable assembly, and connectors should be cleaned using a soft clean cloth moistened with isopropyl alcohol.

**CAUTION**

Cleaning products that can erode the plastic parts of the connectors and junction box must not be used. Oils or lubricants of any type other than mentioned in this document must not be used on or around the junction box.

**CAUTION**

It is recommended that the mating face of each connector be protected by a suitable dust cover, such as TE part numbers 2232227-1 (socket) and 2213228-1 (pin) until the connector is mated. Contamination from dirt, dust or other pollutants of the connector interface can compromise the sealing integrity of the mated PV connector interface in the field.

A. Mounting

1. TE junction boxes can be mounted with the connectors in any orientation when the solar panel is expected to be operating under normal environmental conditions. To ensure the junction boxes and connectors are fully protected from adverse environmental conditions, TE recommends that the junction boxes are mounted to protect the connectors from damage due to environmental factors.
2. The PV Edge is available with double sided mounting tape inboard of the silicone seal that bonds the box to the panel while the silicone sealant cures. The backing of the tape must be removed before mounting the box. Care must be taken to avoid applying silicone sealant over the tape, interfering with the tape bond.
3. When applying the Silicone sealant or double sided adhesive tape to mount the junction box to the solar panel, it is recommended that the junction box remains open and the junction box cover is not attached.

**NOTE**

The referenced double-sided adhesive tape should be tested by the customer for suitability before using it on solar panels that are not entirely flat. The double-sided adhesive tape is only intended to hold the junction box in place during the time required to cure the silicone adhesive. The tape is not intended to hold the box in place with PV4-S1YX cables attached. If cables are attached to the box before the silicone adhesive is applied, the cables must be supported to prevent stressing the silicone adhesive while it cures. The customer must develop and qualify a robust solar box mounting procedure to insure the silicone adhesive fully cures with an airtight seal between the junction box and their specific solar panel materials & surface finish.

4. For applications that require immediate connection and/or handling where the silicone adhesive may be disturbed, a hot melt adhesive can be used to replace the double sided mounting tape. TE has evaluated 3M 3748 Hot Melt Adhesive for compatibility with the PV Edge materials and DOW PV-804 silicone sealant. PV Edge junction boxes can be ordered without the double sided mounting tape to allow the use of hot melt adhesive. Care must be taken to avoid any strings or stray drips of hot melt adhesive from interfering with the electrical connections of both the PV4-S1YX, and the foil rail contacts, the perimeter seal of both the silicone sealant and the O-ring seat on the PV Edge, and the PV4-S1YX connector interface seal seat and small O-ring. The customer must develop and qualify a robust solar junction box mounting procedure to insure the hot melt adhesive does not interfere with these critical areas of the PV Edge. See Figure 4 for possible locations to apply hot melt adhesive. Note that the Hot Melt Adhesive should be applied after the

silicone sealant, just before the box is mounted, so the hot melt adhesive does not cure before the box is placed due to the limited 45 second “open time” of the hot melt adhesive.

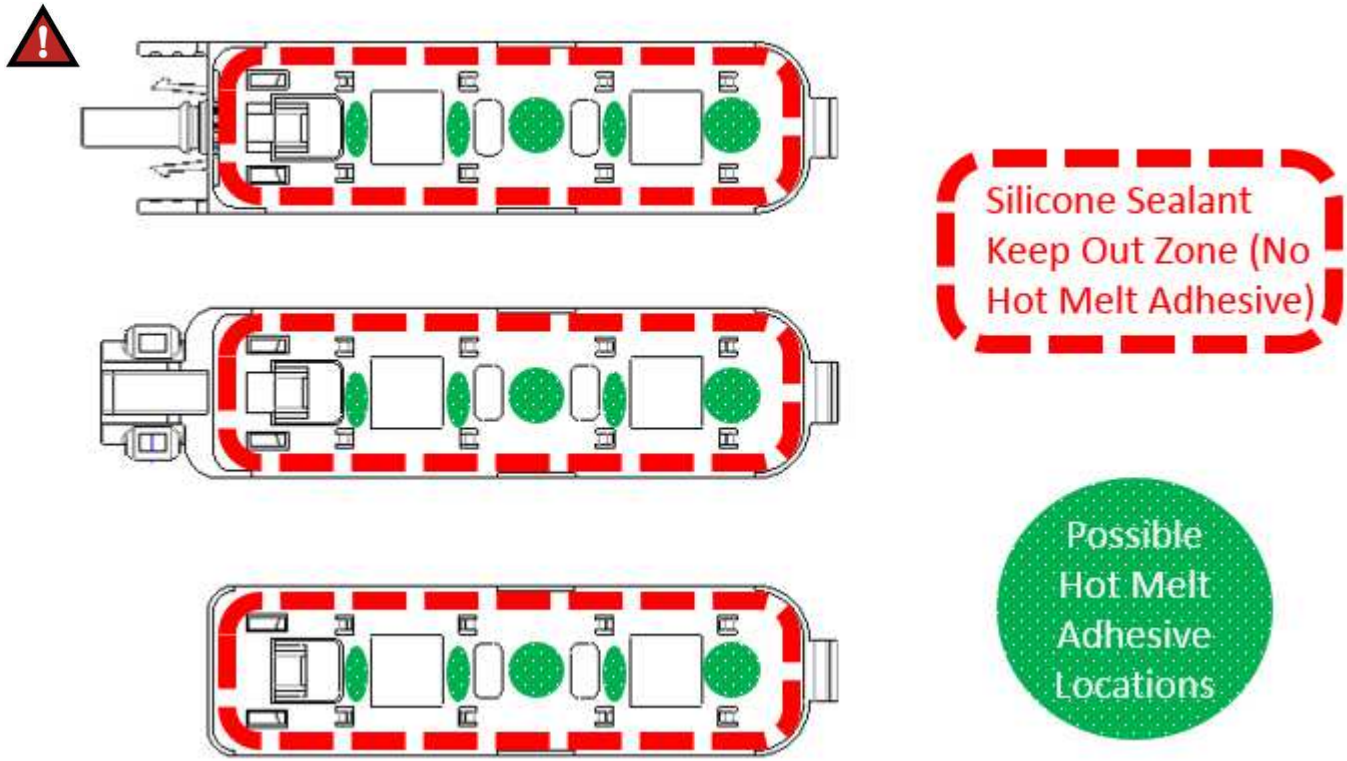

Figure 4, Hot Melt Adhesive Application Locations

DANGER

When working with Silicone sealant, avoid contact with eyes. If eye contact occurs, rinse the eyes for 15 minutes and seek medical attention. Avoid prolonged contact of Silicone with skin.

5. A 6- to 9-mm wide band of the Silicone sealant must be applied to the attachment area (located on the bottom) of the base (shown in Figure 4). The band must be continuous and free of gaps. If desired, the band may be smoothed using a small spatula or brush to ensure a uniform and gap-free application.

Glass-Glass

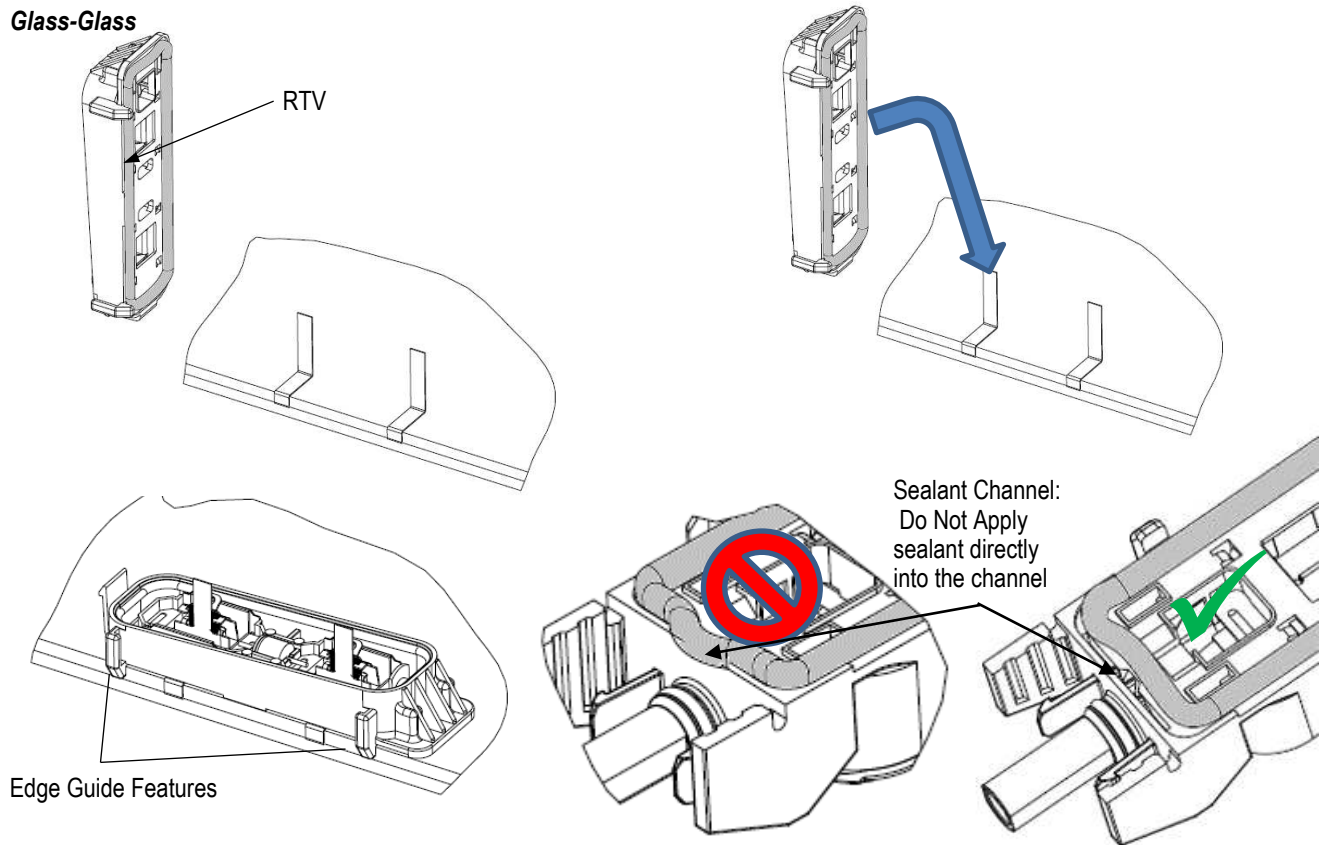

Figure 5 (cont'd)

Traditional Mid-Panel

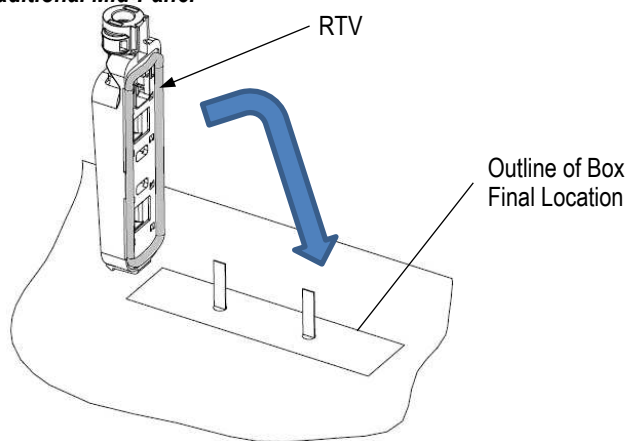

Figure 5 (end)

6. The junction box must be placed onto the attachment area of the solar panel with the foil tabs of the solar panel routed through the back of the open areas of the junction box. For Glass-Glass, use the built-in edge guides on the box to align the box with the edge of the solar panel.

7. The junction box must be oriented horizontally, then pressed onto the solar panel until it is secure. The diodes, diode legs, and contact rails must not be handled or pressed when securing the junction box to the solar panel. To ensure adequate Silicone sealant coverage in the attachment area, a 1-kg [2-lb] metal weight can be positioned on the top of the closed lid of the junction box.



CAUTION

Do not allow excess sealant to flow into the lid sealing zone, onto the foil or contact rails, or into the PV4-S1YX interface areas. Extra care is needed around the + Box with the integrated PV4-S1YX Connector. Excess sealant can extrude out from under the junction box into the PV4-S1YX mating face zone. After the sealant cures in this zone, it can impede mating the PV4-S1YX connector. The + Type Boxes have a channel to allow excess sealant to flow into the channel away from the PV4-S1YX interface area. Do not apply sealant directly into the channel.



CAUTION

Handling or pressing the diodes, diode legs, or contact rails can cause mechanical stress on the components and result in malfunction of the solar panel.

8. The junction box must be kept in a horizontal position until the adhesive has fully cured. The Silicone sealant must be fully cured before terminating or testing the junction box.
9. For Glass-Glass mounted junction boxes, attach the edge flap using the following procedure shown in Figure 6:
 - a. Apply a bead of RTV approximately 5 mm (minimum) in diameter along the inside corner of the edge flap and along its perimeter. Also apply RTV to the small areas of exposed foil that exits between the glass layers on the edge of the panel. Be sure to completely cover the foil with the RTV to insure a good seal. The flap has a recessed area in the center top place optional double-sided tape to hold the flap in place until the RTV cures.
 - b. Insert the edge flap into the track features integrated into the junction box.
 - c. Rotate the edge flap closed and press the flap against the top side of the panel.

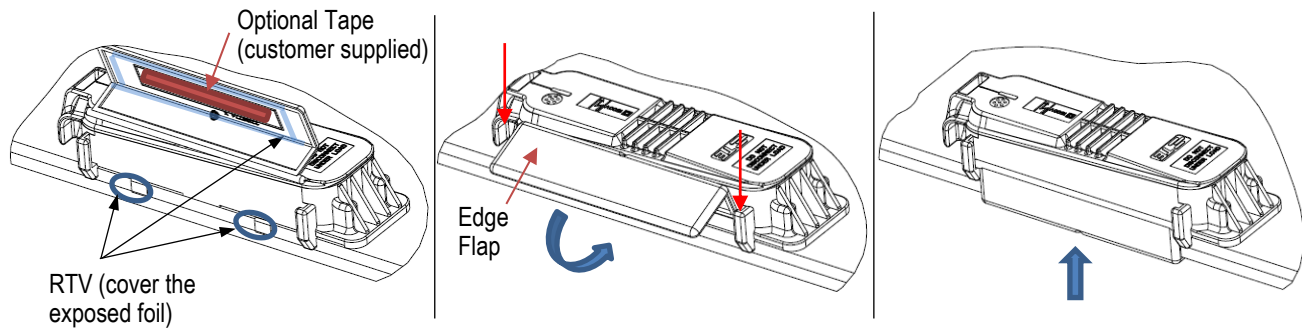

Figure 6



NOTE

The Silicone adhesive must be allowed to fully cure, before the termination process.



NOTE

RTV must be applied on the flap after closure, as shown below



Figure 7

3.7. Termination

1. Each foil tab of the solar panel must be positioned on the junction box as follows. See Figure 8.

JUNCTION BOX TYPE	FOIL TAB THICKNESS	FOIL TAB WIDTH	FOIL TAB POSITION	REFER TO
Foil Clamp Ω Clip	0-0.45 mm	9 ± 1 mm	Wrapped Over Interface Tab of Contact Rail ■	Figure 9a and 9b
	>0.45 mm	9 ± 1 mm	Laid Against One Side of Interface Tab of Contact rail	
Foil Clamp S Clip	0-0.6 mm	9 ± 1 mm	Insert the Foil Tab Into Clamp Gap While Opening the Clamp	

■ To avoid buckling and improper seating of the foil clip, the foil tab should be wrapped over the interface tab as far as possible past the serrations of the interface tab without touching the contact rail. Refer to Figure 8.

Figure 8

2. For the Ω clip type junction box, using foil clip pliers TE part number 5-1579002-0, the open end of each foil clip must be spread apart to a maximum of 1.5 mm to enable the foil clip to slide over the thickness of the foil tab of the solar panel and interface tab of its respective contact rail, and then released. One Ω foil clip must be installed onto each interface tab. Refer to Figure 9a.

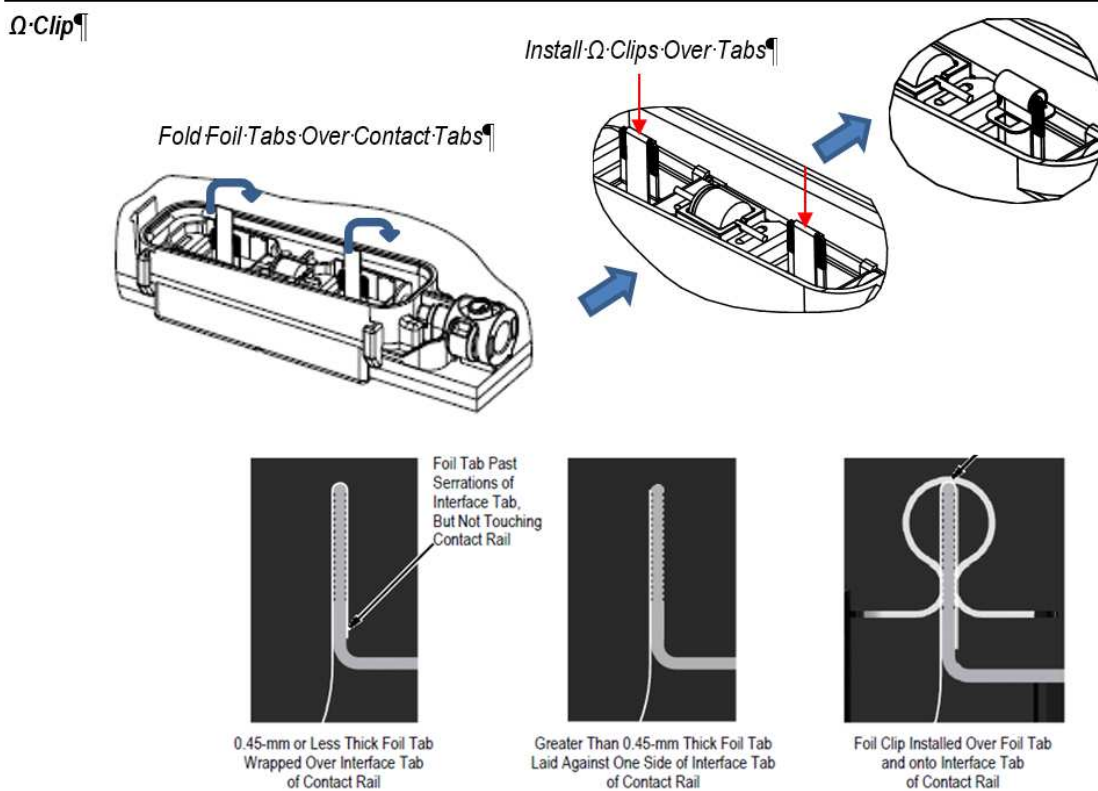

Figure 9a

S-Clip

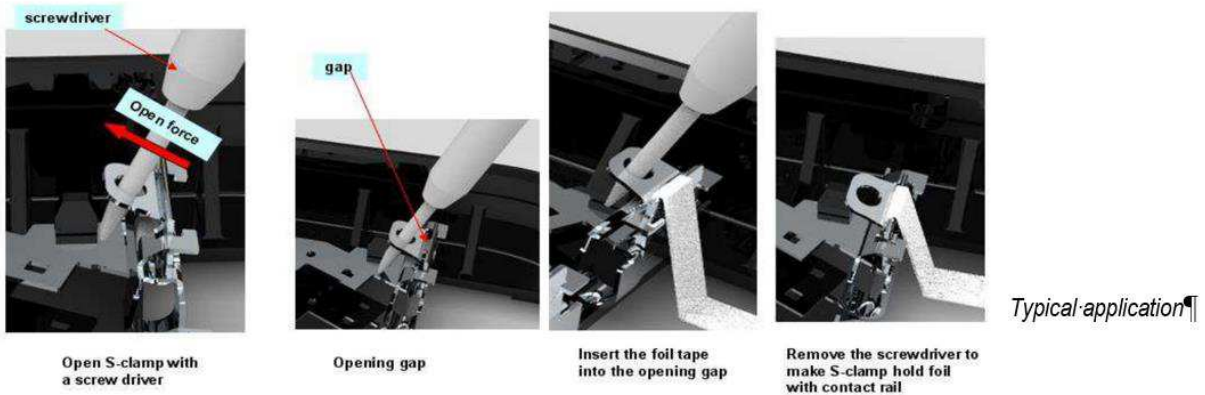
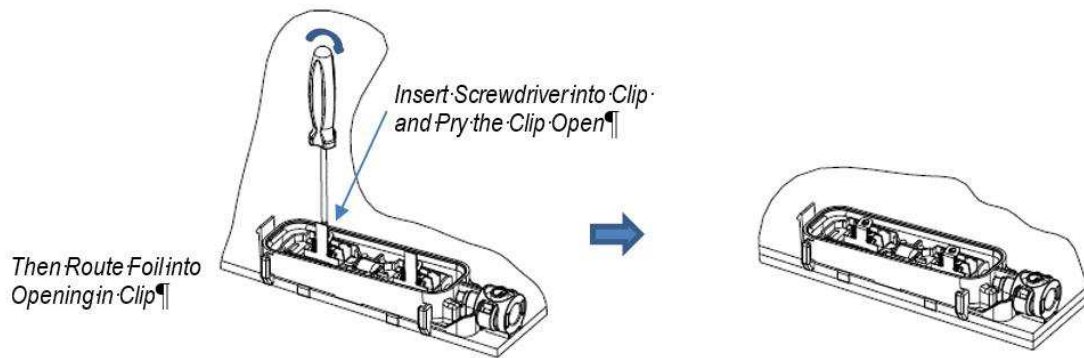

Figure 9b

i **NOTE**
 For Terminated Welded Type application contact TE Connectivity for additional information on process and welding equipment supply.

3.8. Cable Routing and Strain Relief (Figure 10)

The cable connection to the box is designed to be mated in an axial direction. Any mating, un-mating or cable pull applied in a non-axial direction could result unintended damage to the box and or mating cable connector.

i **NOTE**
 Care should be taken to ensure that the cable is not used to carry the solar panel during application.

! **CAUTION**
 Cables must not be bent, stretched, crushed, or confined in any way. The cables must not be bent in the direct exit of the cable screw joint. A minimum bend radius of greater than five times the diameter of the largest cable must be maintained. The cable must be routed so that tensile or angular stress on the connections is prevented. If possible within the application it is recommended that the cable is attached in the application to help to eliminate any potential angular stress applied to the connection.

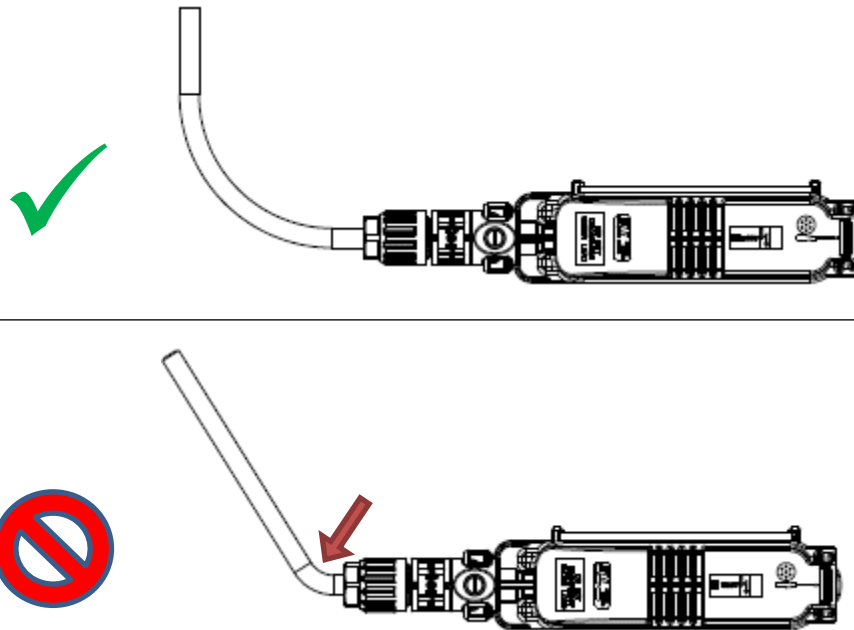

Figure 10

⚠ DANGER
 To avoid personal injury, the circuit load must be DISCONNECTED BEFORE a cable coupler is unplugged. A cable coupler MUST NOT be unplugged under load. DO NOT CONNECT OR DISCONNECT UNDER LOAD!

A hand application tool (Part Number 1971903-1) is available for disconnecting the couplers.

1. The locking mechanism is opened by depressing the latches with this tool as shown in Figure 11.
2. Disconnect the coupler connection while the special tool insertion into the locking mechanism to depress the latches, and pull the couplers apart.

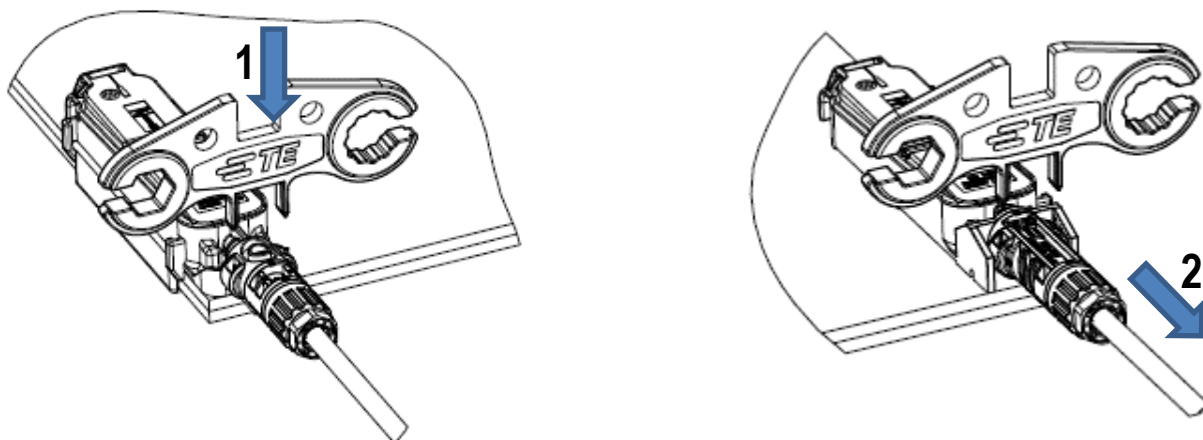

Figure 11

3.9. Closing the Lid (Figure 12)

The lid of the junction box must be attached to the base and then closed properly with the following requirements:



NOTE

If the lid is equipped with a Thermal Interface Material (TIM) pad, peel off the film from the TIM before installing the lid.

1. The two attachment tabs of the lid behave as a hinge and must be inserted into the recesses of the base. The attachment tabs must be properly seated so that the lid can freely rotate when closed.
2. When closed, the latch of the lid must lock into the fastening lugs of the base (there will be an audible “click”). The bottom surface of the lid must be flush with the top surface of the base. The lid must be flat (not bulging). The O-ring of the lid must sit in the groove around the perimeter of the base. No part of the O-ring can protrude from the base. A visual inspection of the O-ring is facilitated by the red coloring of the O-ring against the black color of the PV Edge box and lid.

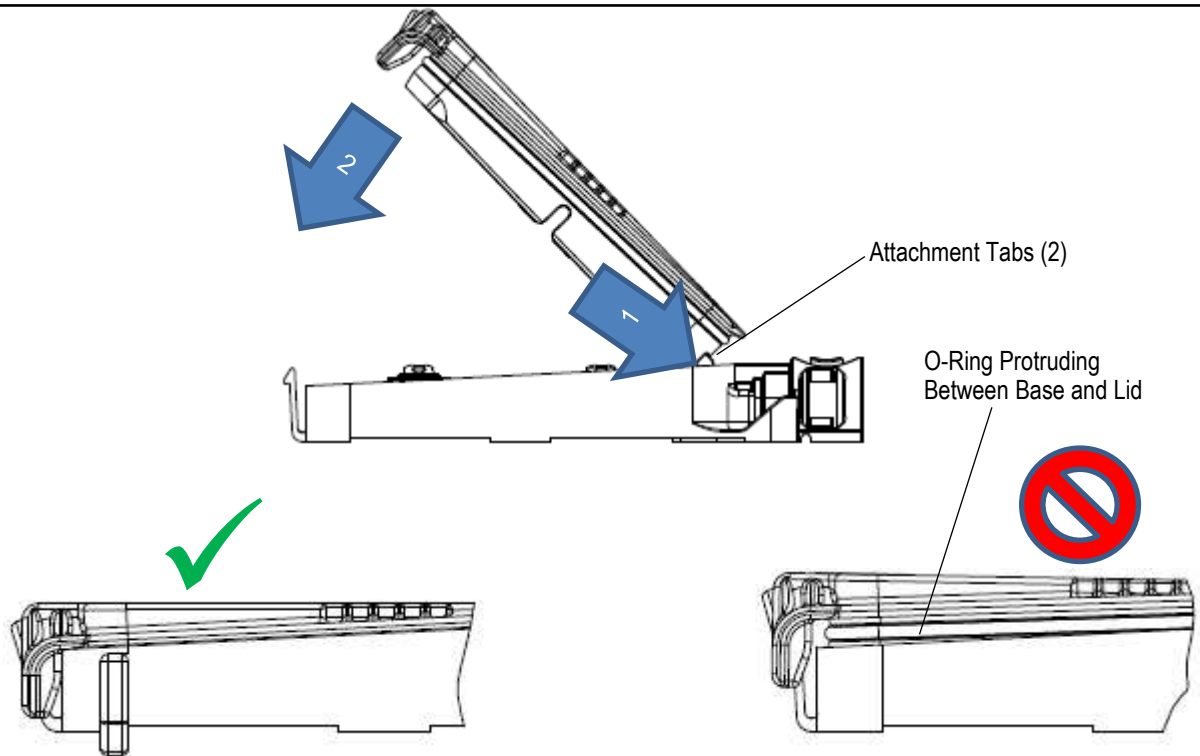

Figure 12



CAUTION

To ensure proper sealing of the junction box and avoid damage to the components inside of the junction box, the O-ring of the lid must be properly fitted in the groove around the base and the lid must be tightly fitted to the base when the lid is closed.



CAUTION

It is recommended to keep the lid installed after the PV Edge boxes are terminated and the silicone sealant is cured to prevent contaminants from interfering with the seal of the lid. Contamination from dirt, dust or other pollutants of the box sealing areas can compromise the sealing integrity of the PV Edge in the field.

3.10. Opening the Lid



CAUTION

Only authorized and trained personnel should open the lid of the junction box.



DANGER

To avoid personal injury or death, the lid of the junction box must NEVER be opened while the junction box is under electrical load. Components inside the junction box may be electrically charged and capable of causing severe injury or death. **EXTREME CAUTION** must be taken when opening the lid of the junction box. **DO NOT CONNECT OR DISCONNECT UNDER LOAD!**

To open the lid of the junction box, the tip of a screwdriver having a 3 to 5-mm flat blade must be inserted into the release pocket of the lid, and then the attachment tab must be pried free while simultaneously slightly lifting the front of lid. See Figure 13.

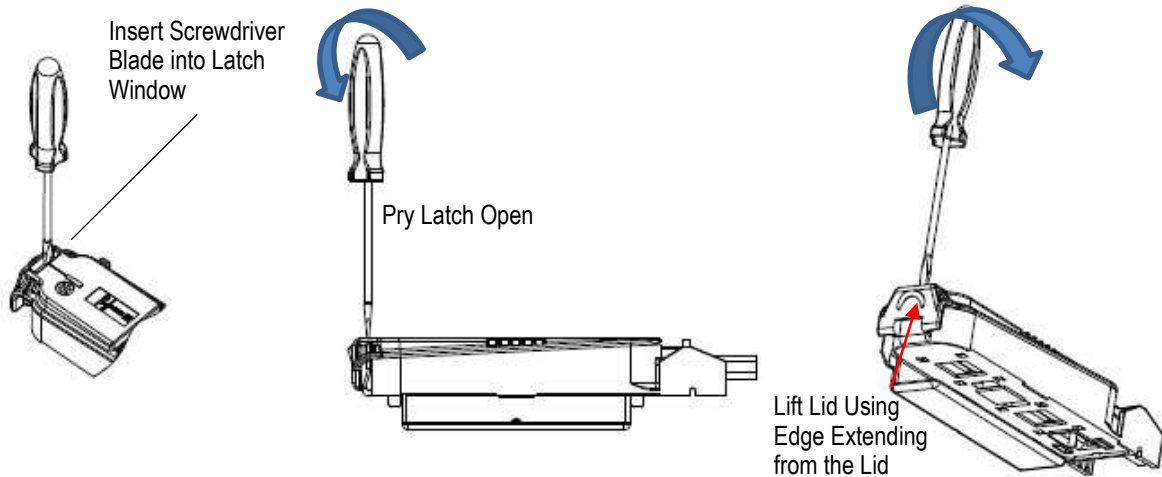

Figure 13

3.11. Serial Wiring Diagram

Figure 14 provides a typical serial wiring diagram.

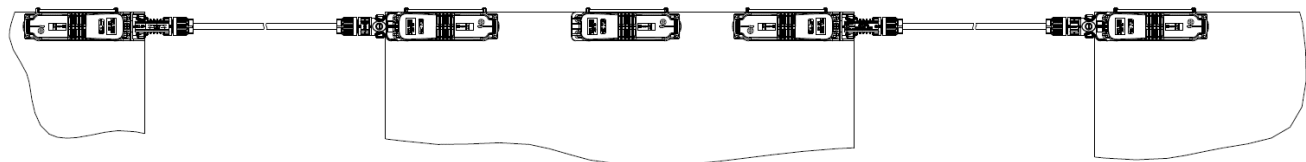

Figure 14

4. QUALIFICATIONS AGENCY APPROVALS

The PV Edge product line has been reviewed for agency evaluation and approval to standards UL3730 and IEC-62790 per the following:

SOLARLOK PV Edge junction boxes are component recognized by Underwriters Laboratory, Inc. in file E321923 Volume 5. Product has been evaluated per the UL3730 standard.

SOLARLOK PV Edge junction boxes have been tested and certified compliant to IEC-62790 by TUV Rheinland. Product is contained within TUV Rheinland certification R60120924.



NOTE

This product is intended to be installed at ambient conditions of 0°C or above per UL3730 section 28.4 and section 41.9. Product use temperature range is specified within applicable agency certificates.

5. TOOLING

The foil clip pliers are used to spread the open end of the foil clip for installation. The Un-Mating tool is required to un-mate the PV4-S1YX connections to the PV Edge box. See Figure 15.

Foil Clip Pliers 5-1579002-0

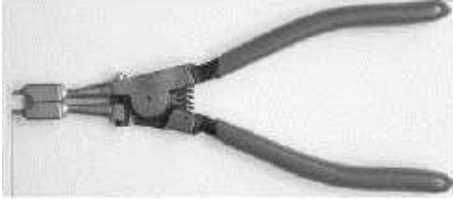

PV4 Un-Mating Tool 1971903-1

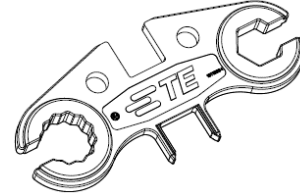

Figure 15

6. VISUAL AID

The illustration below shows a typical application of this product. This illustration should be used by production personnel to ensure a correctly applied product. Applications which do not appear correct should be inspected using the information in the preceding pages of this specification and in the instructional material shipped with the product or tooling.

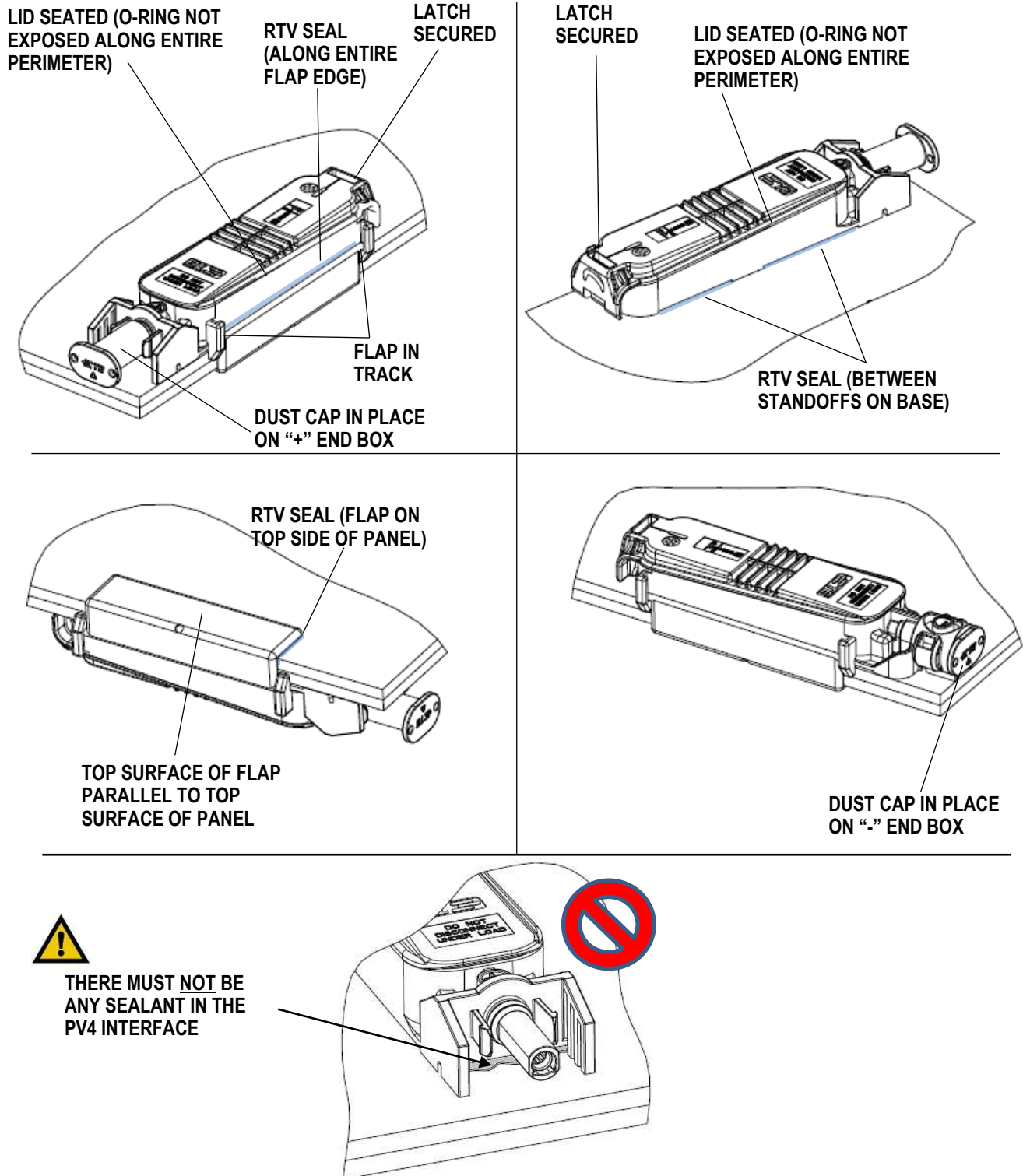

Figure 16 VISUAL AID