

**Figure 1: VITA 67 Backplane and Plug-in Modules.**

## 1. INTRODUCTION

This specification covers the requirements for application of TE Connectivity's multi-position, backplane and daughter card RF modules. The connector system provides a high density, blind mate, RF interconnect in a backplane/daughter card configuration as outlined in the ANSI/VITA 67 series of standards. The VITA 67 products support VPX embedded computing architecture and allow RF signals transmitted from plug-in computing modules to a common backplane.

The RF multi-position modules were designed to be used in VPX 3U and 6U applications but can also be used in custom platforms and as stand-alone mating connectors. The modules are available in standard 4 position (VITA 67.1) or 8 position (VITA 67.2) module sizes but custom configurations and sizes are also supported. The daughter card modules have cavities that are used to retain floating SMPM cable jack contacts. The backplane modules are available in one-piece feed thru designs with a smooth bore SMPM male interface

for the backplane-to-daughter card interface and either an integrated full detent SMPM male interface or OSMM threaded interface on the rear side of the backplane. In the 8 position backplane size, TE also offers a 2 piece module that requires a special SMPM smooth bore male cable plug be inserted in them for mating to the daughter card modules. The multi-position, RF modules are designed to be mounted to either a printed circuit board or panel using a specific mounting pattern and using hardware (not supplied) to attach the modules. The modules also can be used with VITA 46 guide hardware that is purchased separately. The guide pin and guide module are recommended to be used with the multi-position modules to eliminate any misalignment that may occur during mating of the modules.

When corresponding with TE personnel, use the terminology provided in this specification to facilitate your inquiries for information. Basic terms and features of these products are provided in this specification.

## 2. REFERENCE MATERIAL

### 2.1 Revision Summary

- Revision B: Added content covering new Snap-in Floating Cable Jack product in sections: 2.2-3.1

### 2.2 Customer Assistance

Reference Product Base Part Numbers [1996705-4](#), [1996706-1](#), [1996390-1](#), [1996777-2](#), [1996884-1](#), [2332676-1](#), [2332676-2](#), [2332706-1](#), [2361107-1](#), [2365211-1](#), [2332684-1](#), [2332684-2](#), [2332707-1](#), and [2332708-1](#) are representative of the TE VITA 67 RF Modules and Contacts. Use of these numbers will help to identify the product line and help you to obtain product and tooling information. Such information can be obtained through a local TE Representative, by visiting our website at [www.te.com](http://www.te.com), or by calling PRODUCT INFORMATION at the number on the bottom of page 1.

### 2.3 Drawings

Customer drawings for the product line are available from [www.te.com](http://www.te.com). Or, call the Product Information number at the bottom of page 1.

**NOTE**  
 If there is a conflict between the information contained in the Customer Drawings and this specification or with any other technical documentation supplied, the information contained in the Customer Drawings takes priority.

### 2.4 Specifications

Product specifications (108-series) provide expected product performance and test information for the Multi-position, High Density, Backplane and Plug-in RF modules. Qualification test reports (501-Series) confirms the successful qualification per the product specifications. The following specifications are applicable to this product:

- [108-2443](#) Modular, High Density, RF Connection System
- [108-2443-1](#) Modular, High Density, RF Backplane, Connection System with Compliant Pin Terminations
- [108-163026](#) RF SMPM, Coaxial, Snap-In Connector System for VITA 67 VPX Standard
- [501-748](#) Modular, High Density, RF Connection System

- [501-748-1](#) Modular, High Density, RF Backplane, Connection System with Compliant Pin Terminations
- [501-134113](#) RF SMPM, Coaxial, Snap-In Connector System for VITA 67 VPX Standard

### 2.5 Instructional Material

Instruction Sheets (408-series) provide product assembly instructions or tooling setup and operation procedures. The following Instruction Sheets are applicable to this product:

- [408-10364](#) SMPM Direct Attach Plugs.

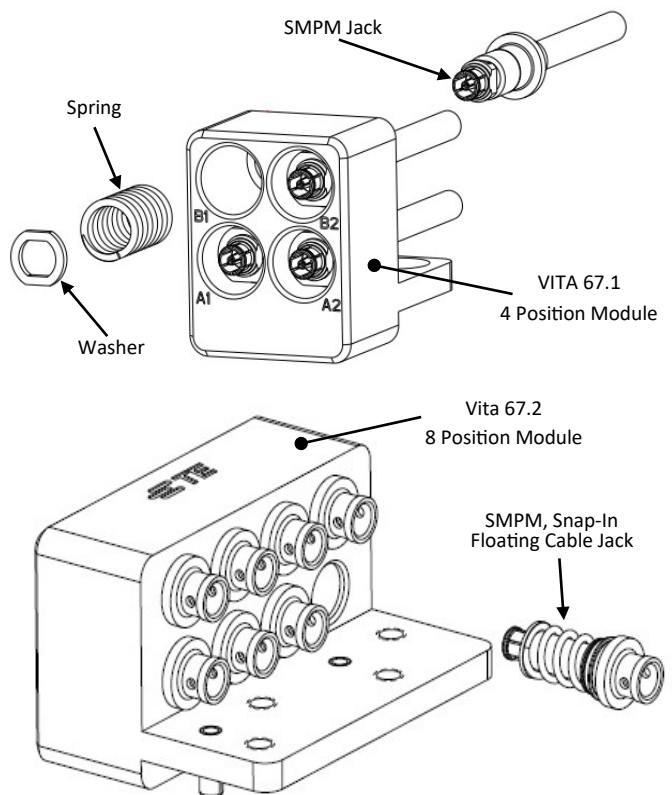

**Figure 2: SMPM Float Mount Jacks in a VITA 67.1 Four Position Plug-in Module & SMPM, Snap-In Floating Cable Jacks in a VITA 67.2 Eight Position Plug-in Module**

- [408-32189](#) MULTIGIG RT 2-R\* Machined Keyed Guide Hardware
- [408-10387](#) VITA 67 Module Mounting Patterns.
- [408-163001](#) Vertical PCB Eye-of-the-Needle (EON) Plug.
- [408-32089](#) SMPM Snap-in Plug Extraction Tool
- [408-10373](#) SMPM Floating Panel Mount Cable Jacks.
- [408-163023](#) SMPM, Snap-In Floating Cable Jack

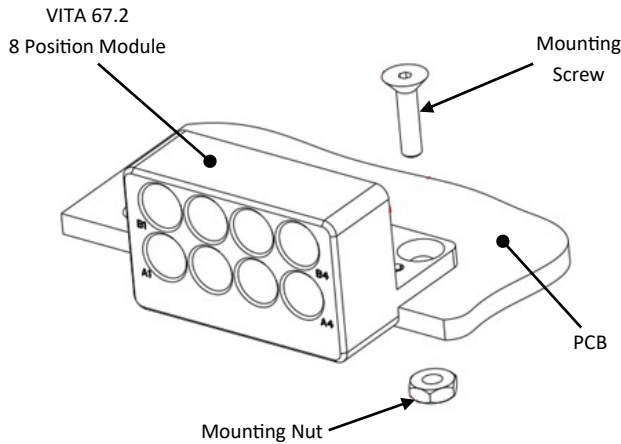
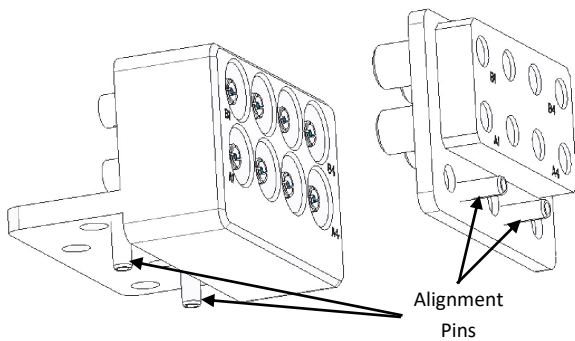

**Figure 3: VITA 67.2 Eight Position Plug-in Module Pressed in Place on PCB**

## 2.6 Standards and Publications

The VITA 67 Product offering was designed around the following standards:

- ANSI/VITA 46.0-2007, “VPX Baseline Standard”
- ANSI/VITA 47-2007, “American National Standard for Environments, Design and Construction, Safety and Quality for Plug-In Units Standard”
- ANSI/VITA 67.0-2012, “VPX Coaxial Interconnect
- ANSI/VITA 67.1-2012, “VPX: Coaxial Interconnect, 3U, 4 Position SMPM Configuration”



**Figure 4: Alignment Pins on the VITA 67 Modules**

- ANSI/VITA 67.2-2012, “VPX: Coaxial Interconnect, 6U, 8 Position SMPM Configuration”

## 3. REQUIREMENTS

### 3.1 Plug-in Modules (Daughter Card)

The daughter card RF multi-position modules are available in

either 4 position or 8 position options. They are made from either stainless steel or aluminum with a passivated or clear trivalent chromate conversion finish depending upon the module material chosen. The daughter card RF modules are used to retain and position TE Connectivity’s spring loaded,

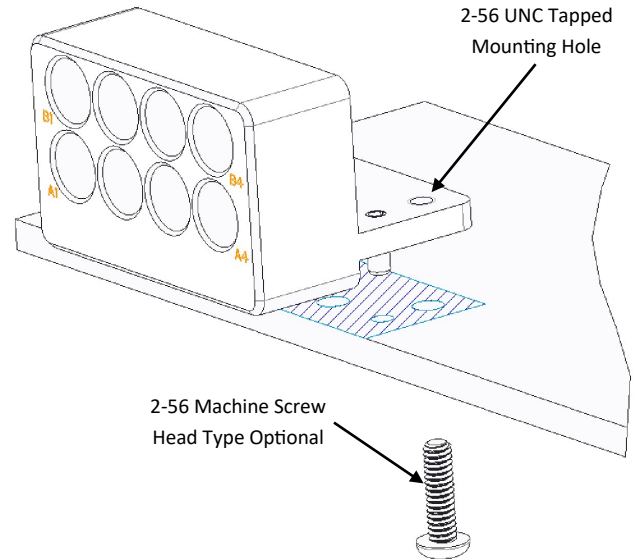

**Figure 5: Module with 2-56 UNC tapped hole for mounting hardware.**

SMPM, floating panel mount, cable jacks (such as part number [1996390-1](#), [2332684-1](#), and [2332684-2](#)). The SMPM, floating panel mount, cable jacks mate to the multi-position backplane RF module to complete the connection. Instruction sheets [408-10373](#) and [408-163023](#) give detailed information on how to assemble the SMPM, floating panel mount, cable jacks onto cable and into the multi-position card module with the floating panel mount, cable jacks installed. Figure 2, shows both a 4 position daughter card module with the floating panel mount, cable jacks installed and shows a 8 position daughter card module with the floating panel mount, snap-in floating cable jacks installed.

The multi-position plug-in RF modules are attached to a printed circuit board or panel with standard hardware (screws, nuts and optional washers) that are not provided with the module when purchased (see figure 5). The design of the printed circuit board or panel layout will depend on the specific type of daughter card RF module used. The thickness of the mounting structure will determine the length of screw required. The module mounting patterns and locations are

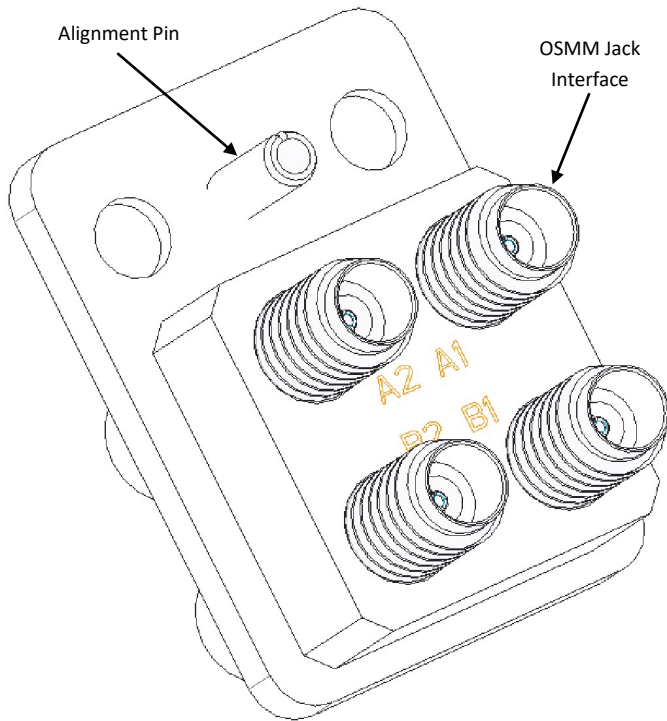

**Figure 6: Four Position Backplane Module with OSMM Threaded Interface.**

documented in the Vita 67.1 and Vita 67.2 specifications and TE Connectivity Instruction Sheet [408-10387](#).

There are 2 alignment pins on every daughter card module that help position the module in the printed circuit board or panel prior to installation of the hardware. The alignment pins on the module are initially pressed into place in the appropriate holes and hold the daughter card module in place on the printed circuit board so that the mounting hardware can be applied to secure the module. The modules are secured to the printed circuit board or panel prior to the floating panel mount, cable jacks being inserted into them.

There are two versions of the daughter card modules that accept different mounting hardware. One is designed to utilize #2-56 UNC-2A flat head screws with an 82° countersink on the head. A corresponding #2-56 UNC-2B nut is used on the screws to secure the module to the printed circuit board or panel as shown in Figure 3. The other type of plug-in module shown in figure 5 has #2-56 UNC tapped holes and requires a #2-56 machine screw and optional washer.

### 3.2 Backplane Modules

The backplane RF multi-position modules are available in either 4 or 8 position options. There are 4 different interconnect choices for the backplane:

- SMPM full detent interface on the back-end of the module;
- OSMM threaded interface on the back-end of the module;
- SMPM plug direct cable attach module (8 position only);
- SMPM PCB plug with eye-of-the-needle contacts.

The modules are made from stainless steel with a passivated or gold plated finish. The SMPM and OSMM modules essentially operate like a feed thru adapter and connect the SMPM floating panel mount cable jacks in the daughter card module on the front side to another cable connector on the back side. On the front side of the backplane module that mates to the multi-position daughter card module there is an SMPM, smooth bore male connection. This SMPM smooth bore male interface is meant to be mated to the SMPM floating panel mount cable jacks installed in the daughter card multi-position module. The back side of the feed-through backplane module has either a full detent SMPM male interface connection or an OSMM jack interface connection. The SMPM full detent male interface on the back side of the backplane module will mate with standard SMPM female cable jacks and the OSMM jack interface on the back side of the module will mate with TE Connectivity standard OSMM cable plugs. The OSMM is a thread-on connector while the SMPM is a push-on interface. Examples of the different backplane module options are shown in figure 1 on page 1.

The multi-position RF backplane modules are attached to a printed circuit board or panel with standard hardware (screws, nuts and optional washers) that are not provided

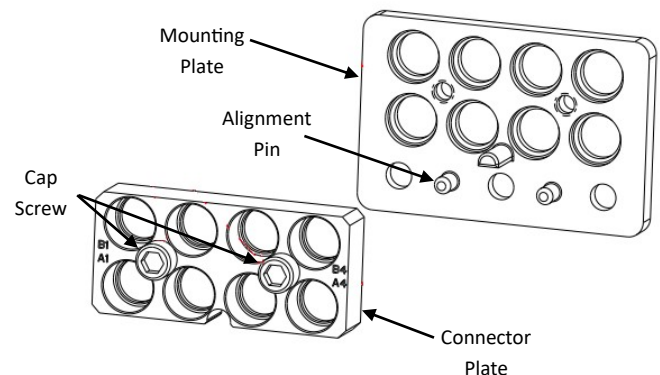

**Figure 7: Direct Attach Module showing two piece construction.**



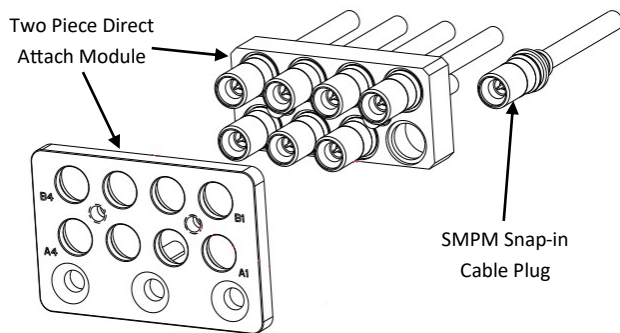

**Figure 8: SMPM Direct Attach Module with SMPM Snap-in Plug Connectors**

with the module when purchased. The thickness of the mounting structure will determine the length of screw required to secure the module to the printed circuit board or panel. The hole patterns required for mounting the module to the printed circuit board or panel are documented in the Vita 67.1 and 67.2 specifications or TE instruction sheet [408-10387](#).

There are two alignment pins on the 8 position modules shown in figure 4 and only one alignment pin on the 4 position modules as shown in figure 6. The alignment pins are initially pressed into the printed circuit board or panel and hold the backplane module in place until the mounting hardware can be applied to secure the module. The mounting holes in the backplane RF modules are designed to accept a #2-56 UNC-2A flat head screw with a 100° countersink head. A corresponding #2-56 UNC-2B nut is used on the screws to secure the module to the printed circuit board. There are two mounting holes in the 4 position modules and the 8 position modules have three mounting holes. Figure 1 shows an 8 position backplane module with the mounting screws attached to the printed circuit board.

The direct attach backplane RF module is only available in the 8 position configuration. This 2 piece backplane module is designed to eliminate one of the separable interfaces on the back side of the module. The 2 piece backplane module consists of a mounting plate and a connector plate with 2 captive cap screws. The 2 piece backplane RF module is shown in figure 7 and 8 and is designed to be used with a special SMPM snap-in cable plugs (Ref. TE p/n [2101012-1](#)). As stated above the use of the snap-in SMPM cable plug will eliminate a separable interface connection when using the 2

piece backplane module and mating to the daughter card module.

The 2 piece backplane RF module has the same pattern layout as the standard 8 position backplane and follows the Vita 67.2 specification. The mounting plate of the 2 piece module has two alignment pins and is secured to the printed circuit board using the same #2-56 UNC-2A screws and nuts as the feed-through backplane modules described above. The SMPM snap-in cable plugs used with the 2 piece backplane module are

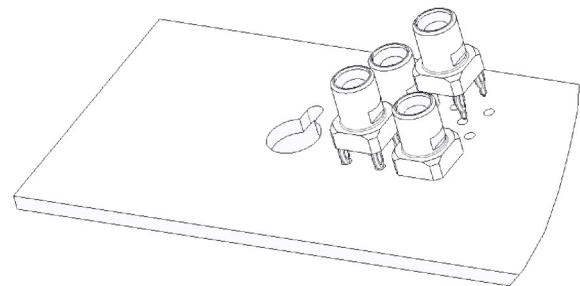

**Figure 9: SMPM PCB Mount Plug with EON Contacts on a VITA 67 Backplane.**

terminated to cable (see instruction sheet [408-10364](#) for termination instructions of the SMPM snap-in plug) and inserted into the connector plate of the 2 piece backplane module.

The snap-in SMPM cable plugs contain a C-ring on the body that will collapse when inserted into the connector plate of the backplane module and once fully inserted the C-ring on the cable plug opens to securely hold the cable plug in the connector plate. Once all the cable plugs are securely inserted into the connector plate of the 2 piece backplane module, the connector plate is attached to the mounting plate (already installed on the printed circuit board) using the two captive cap screws. Figure 8 shows a 2 piece backplane module with the SMPM snap-in cable plugs inserted into the connector plate and ready to be attached to the mounting plate.

In order to remove the snap-in SMPM cable plugs from the direct attach module, the connector plated must be removed from the mounting plate. Extraction tool P/N [2161640-1](#) can then be used to collapse the C-ring and push the contacts out of the connector plate as described in instruction sheet [408-32089](#).

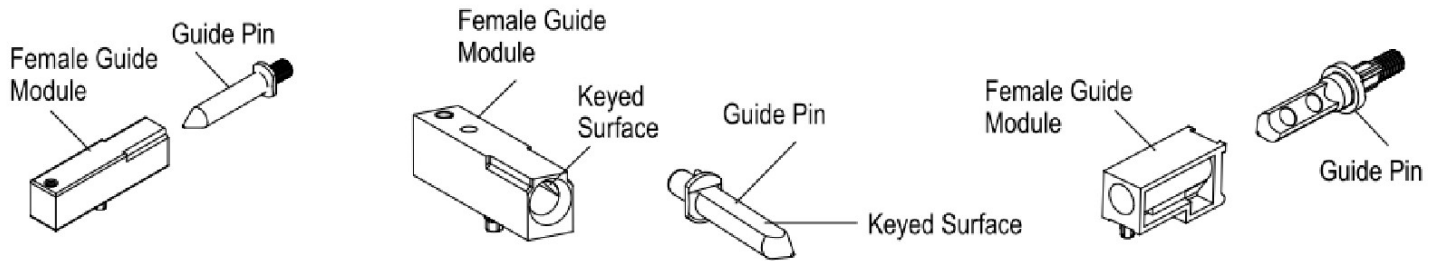

Figure 10: VITA Guide Hardware

**TE CONNECTIVITY GUIDE HARDWARE PART NUMBERS**

	Universal Guide Hardware	VITA 46 Guide Hardware	Rugged VITA 46 Machined
<b>Guide PIN</b>	<a href="#">223969-X</a>	<a href="#">1-1469491-X</a>	<a href="#">2000676-X</a>
<b>Guide Module</b>	<a href="#">5223979-X</a>	<a href="#">1-1469492-X</a>	<a href="#">2000713-X</a>

In some cases when terminating flexible cable to the SMPM snap-in cable plugs, the column strength of the cable is not sufficient to overcome the force needed to snap the plugs into the connector plate of the 2 piece module. In those cases, Astro Tool corporation part number AT1159 can be used to insert the snap-in cable plugs into the connector plate. The AT1159 tool will allow the terminated cable of the snap-in plug to pass through the tool and the tool pushes on the flange of the snap-in cable plug to insert the plug into the connector plate as described in the instruction sheet.

TE Connectivity P/N [1996318-1](#) is a vertical SMPM Plug connector that terminates into a PCB with eye-of-the-needle (EON) contacts. The connector is designed to provide the proper mating height off the PCB to properly engage the VITA 67 plug-in module SMPM float mount jacks. A set of 4 or 8 of these SMPM PCB Connectors can be used in place of one of the modules to terminate directly into the PCB.

Hole pattern and plated through hole requirements can be found on the customer drawing. Hole locations relative to the VITA backplane can be found in instruction sheet [408-10387](#),

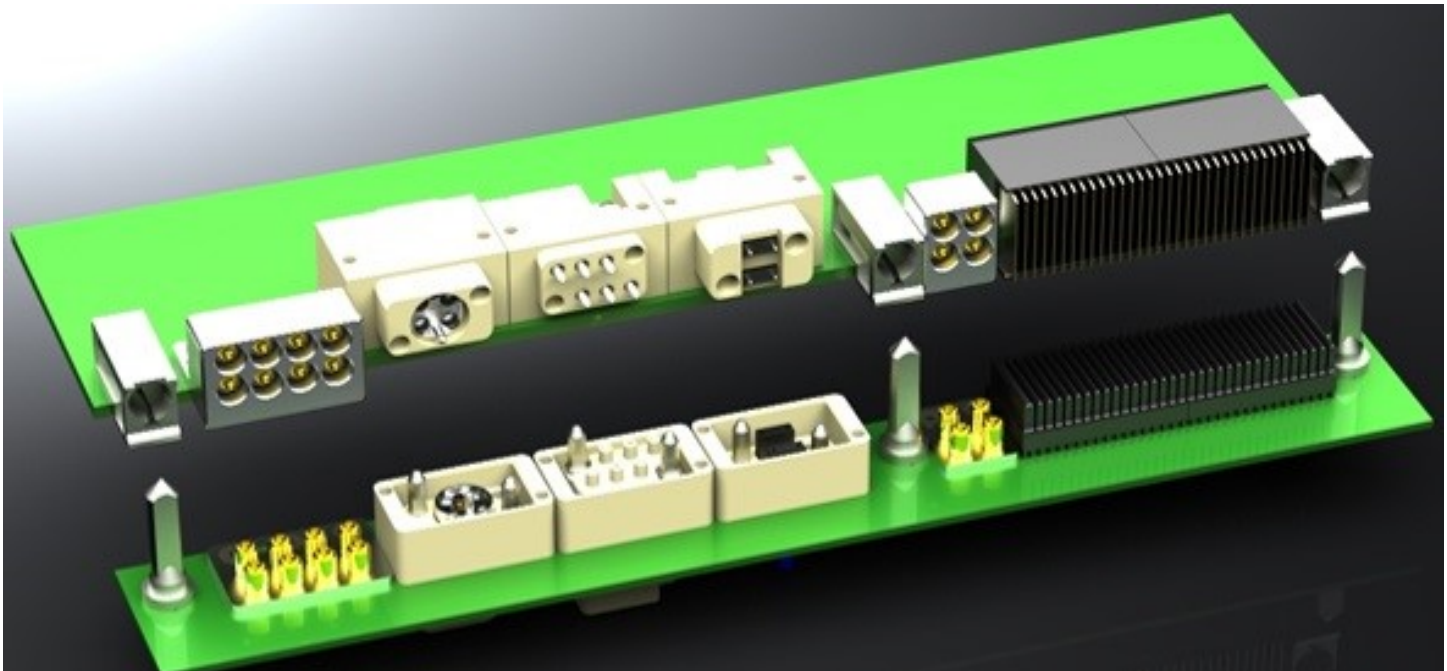

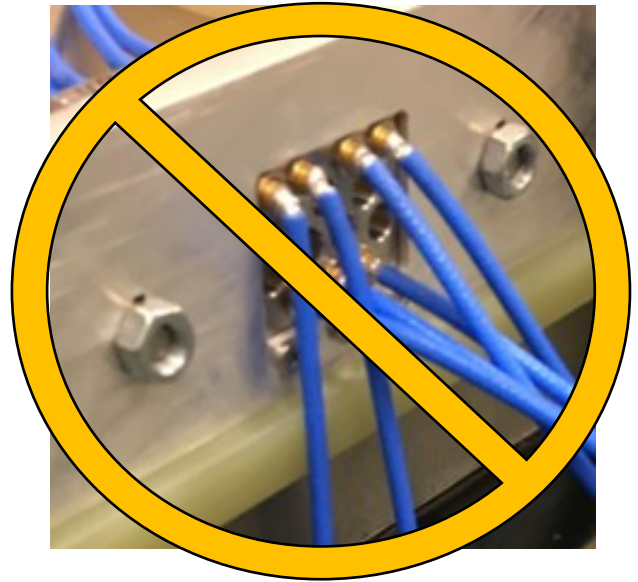



Figure 11: A VPX 6U application featuring VITA 67.1 and VITA 67.2 RF Modules, VITA 66 Fiber Optic Modules and TE Connectivity's Ultra-Rugged MULTIGIG RT 2-R VITA 46 high Speed Connector System.

#### 4.0 Application Caution Warnings



 When dressing and routing the cables soldered to the VITA 67 connectors, care must be taken to avoid damaging the cable and solder joint due to excessive side loads. The cable manufacturer's Minimum Bending Radius must never be violated to avoid permanent damage to the cable or the solder joint at the connector. Typically these loads must be less than 1 lbf when applied to the connector cable. In addition to permanent cable damage, side loads on the connectors can cause stubbing and permanent connector damage when the VITA 67 RF Daughter Card module is mated to the corresponding VITA 67 RF Backplane module.



 Cables soldered to the connectors must be allowed to float independently when applied to the module bodies. Never restrict individual cable assembly movement by gathering cables together in a module by zip tie or other fastening mechanism. Each cable assembly must be able to move (float) independently and freely from each other. If the cables are not free to independently float, permanent connector damage can occur when the VITA 67 RF Daughter Card module is mated to the corresponding VITA 67 RF Backplane module.

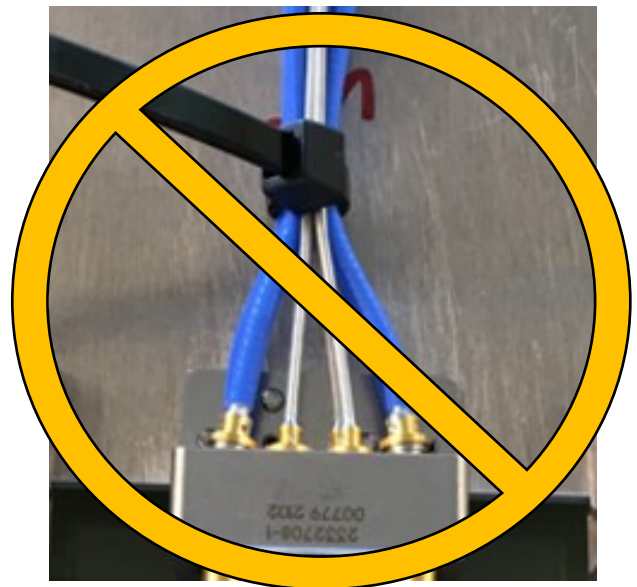

 Note that the connectors designed for snap-in module bodies are not compatible with module bodies designed for spring washer connectors and vice versa.

