

P	LTR	DESCRIPTION	DATE	DWN	APVD
B7		ECR-21-123594	29JAN2022	RK	JB

NOTES:

- PIN/BOLT VARIANT: POS.4 FITTED WITH POS.17 BOLTING AND POS.14, 15 AND 16 MOUNTED ON BOLT TERMINATION
- SCREW VARIANT: POS.4 OF FITTED WITH POS.9 BOLTING POS.6, 7 AND 8 IN POLY BAG PACKING
- PACKAGING QUANTITY: 5 PIECES IN A CARTON BOX
- OBsolete PARTS: OBSOLETE CIS STREAMLINING PER D.RENAUD/D.SINISI

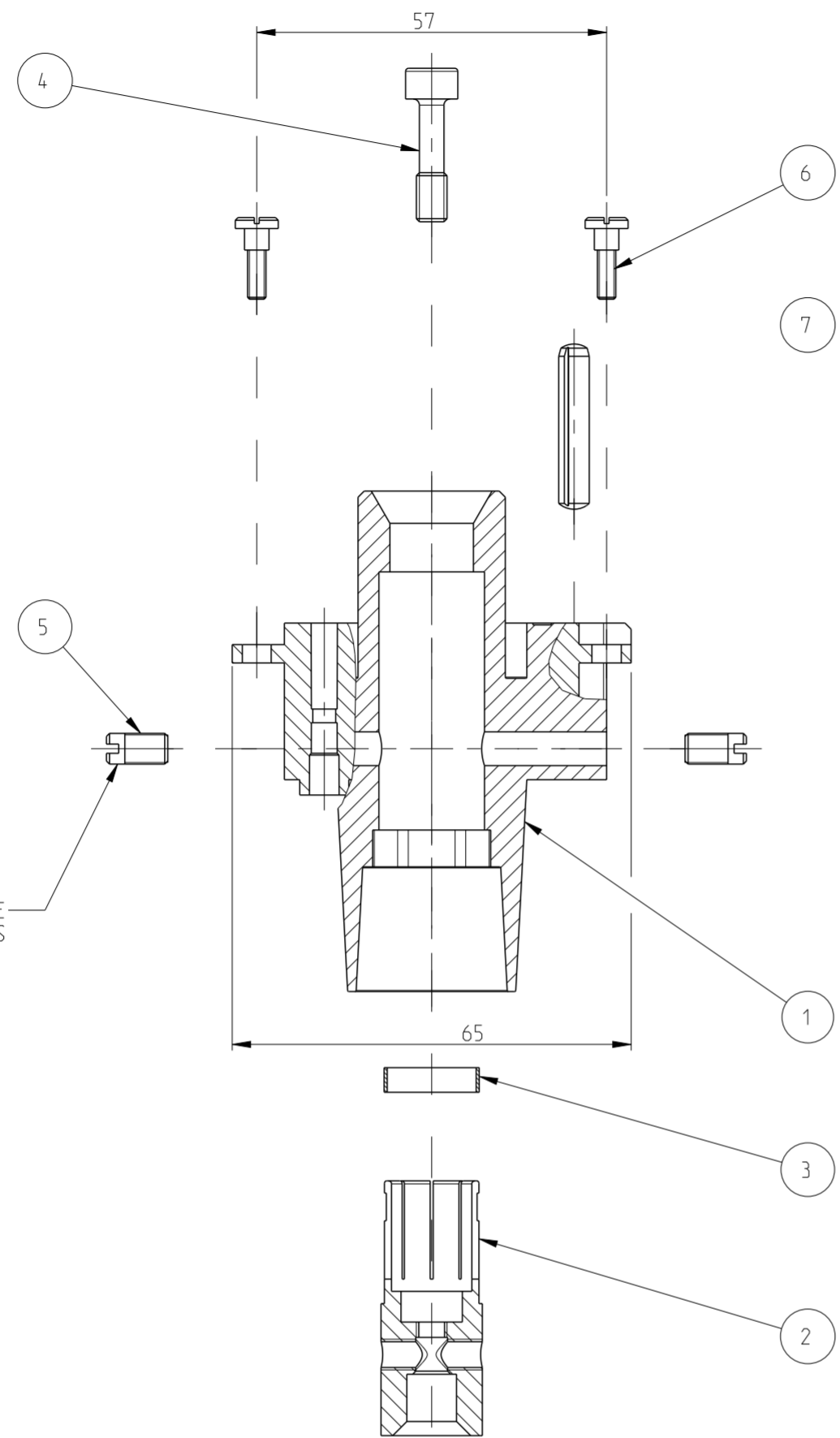

PIN/BOLTING TERMINATION VARIANT

SCREW VARIANT

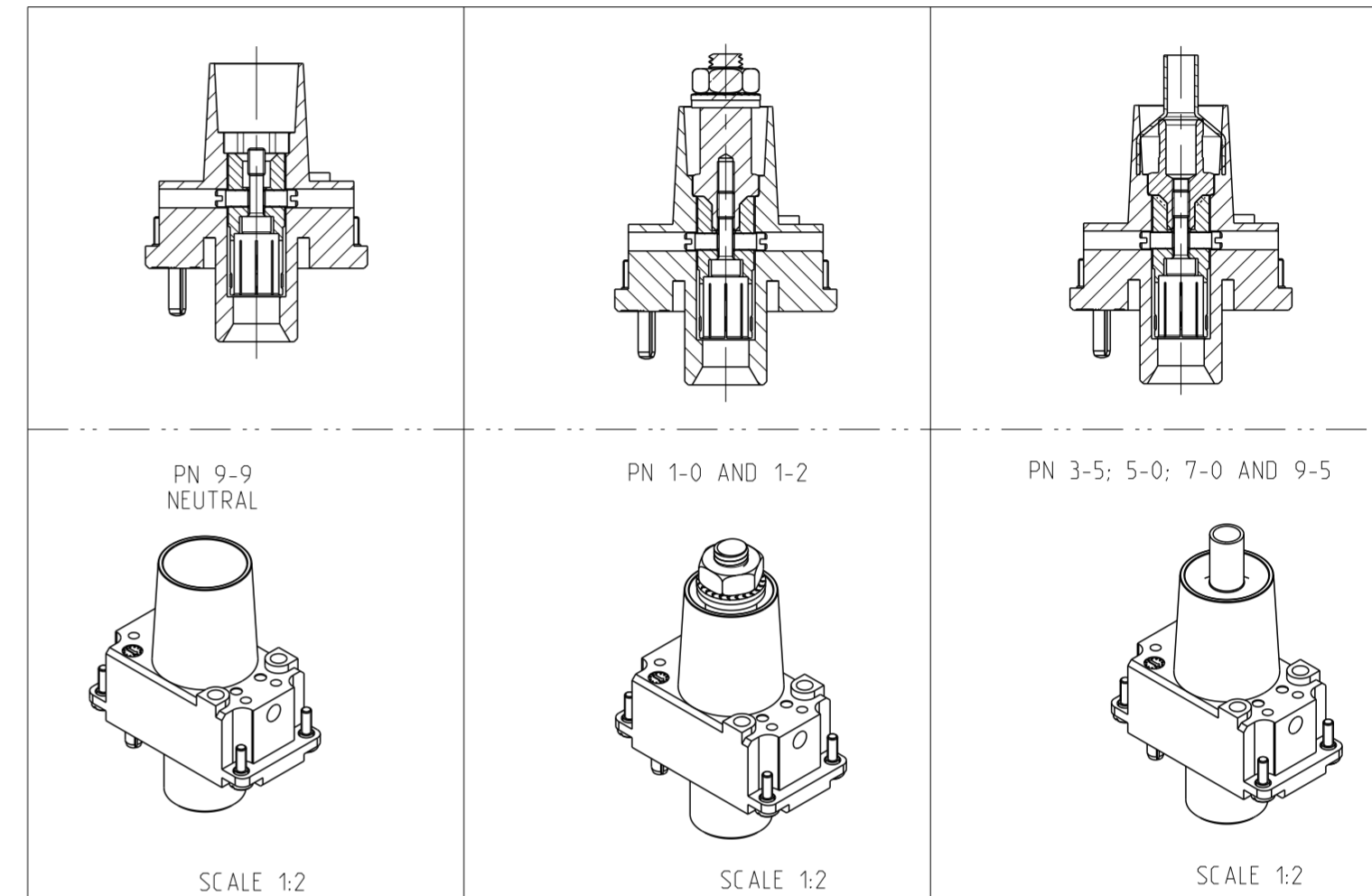
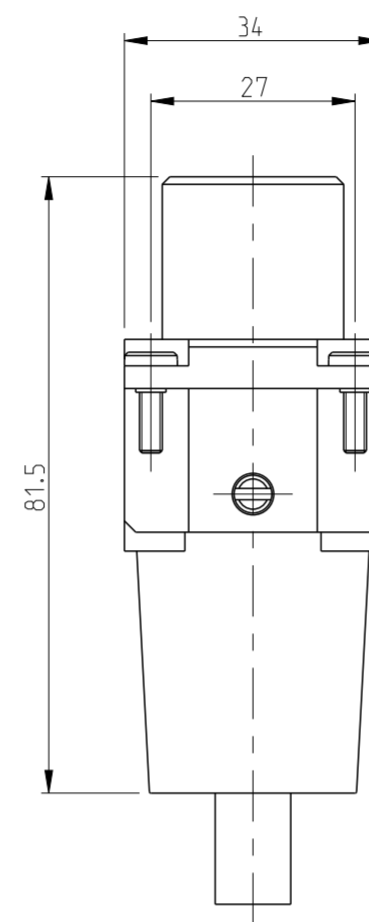
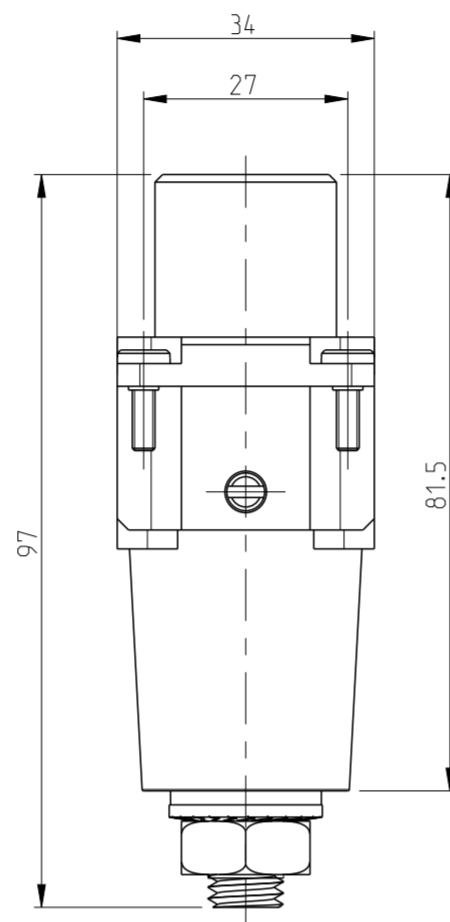

WITH LOCTITE SECURE SCREW POS.4 MUST BE ABLE TO PASS

PIN/BOLTING TERMINATION VARIANT

SCREW VARIANT

CRIMPING PROCESS

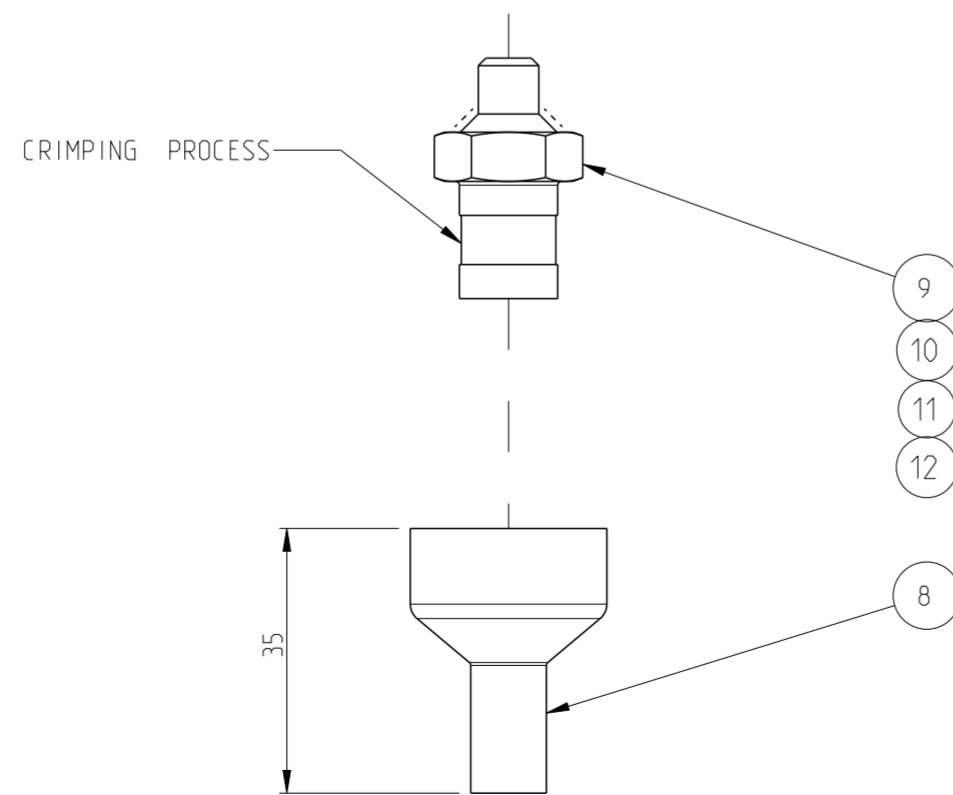
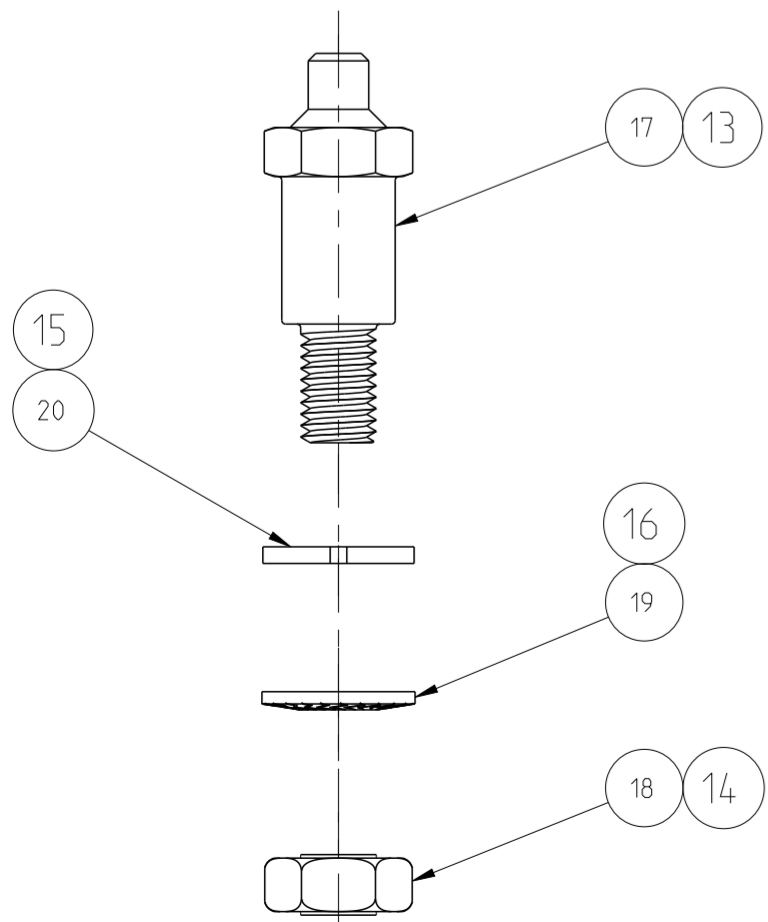

QTY	DESCRIPTION	MATERIAL	ITEM NO	SURFACE	COLOR	REMARKS
1	WASHER, PLAIN	BRASS	20	SILVERED		DIN 125
1	WASHER	STEEL	19	SILVERED		SKS10
1	NUT M10	MILD STEEL	18	SILVERED		DIN EN 28673
1	BOLT TERMINATION FOR SOCKET CONTACT AG	CuZn39Pb2	17	SILVERED		
1	WASHER	STEEL	16	SILVERED		SKS12
1	WASHER, PLAIN	BRASS	15	SILVERED		DIN 125
1	NUT M12	MILD STEEL	14	SILVERED		DIN EN 28673
1	BOLT TERMINATION FOR SOCKET CONTACT AG	CuZn39Pb2	13	SILVERED		
1	BARREL 95mm2	CuTeP(2.1546)	12	SILVERED		
1	BARREL 70mm2	CuTeP(2.1546)	11	SILVERED		
1	BARREL 50mm2	CuTeP(2.1546)	10	SILVERED		
1	BARREL 35mm2	CuTeP(2.1546)	9	SILVERED		
1	SHRINKABLE TUBE	POLYOLEFIN	8		BLACK	35mm
2	Grooved pins / Rivet pins	STAINL.STEEL	7	BLANK		DIN EN 28740
4	SCREW, SLOTTED PAN HEAD	STAINL.STEEL	6	BLANK		DIN 923
2	SCREW M5	STAINLESS STEEL	5	BLANK		DIN 427
1	SCREW, HEX. SOCKET HEAD CAP	STAINL.STEEL	4	BLANK		SIMILARLY DIN EN ISO 4762
1	ROUND SPRING	STAINL.STEEL	3	BLANK		
1	SOCKET CONTACT FOR AG	Cu Sn 8	2	SILVERED		
1	FEMALE INSERT AG	PA66 (Ultramid A3x3G5)	1			

THIS DRAWING IS A CONTROLLED DOCUMENT.

DWN Kramer 24.11.97  
CHK Schweiger 24.11.97  
APVD -



DIMENSIONS: mm	TOLERANCES UNLESS OTHERWISE SPECIFIED: 0 PLC ± 1 PLC ± 2 PLC ± 3 PLC ± 4 PLC ± ANGLES ±
MATERIAL	FINISH

PRODUCT SPEC	108-74021	NAME	ASSEMBLY SOCKET INSERT AG AM-4P/13
APPLICATION SPEC	114-74023	SIZE	A2
WEIGHT	ca. 180g	CAGE CODE	00779
CUSTOMER DRAWING		DRAWING NO	C-1110028
SCALE	1:1	SHEET	1 OF 1
REV	B7	RESTRICTED TO	-