

REVISIONS				
P	LTN	DESCRIPTION	DATE	APVD
A3		Released as per ECR-07-019955	22.08.07	SK TS
A4		REVISED PER ECR-09-027197	19JAN10	KK HMR
A5		REVISED PER ECR-17-013084	02APR2018	SF MKO
A6		REVISED PER ECR-24-207624	29MAY2024	RK WR

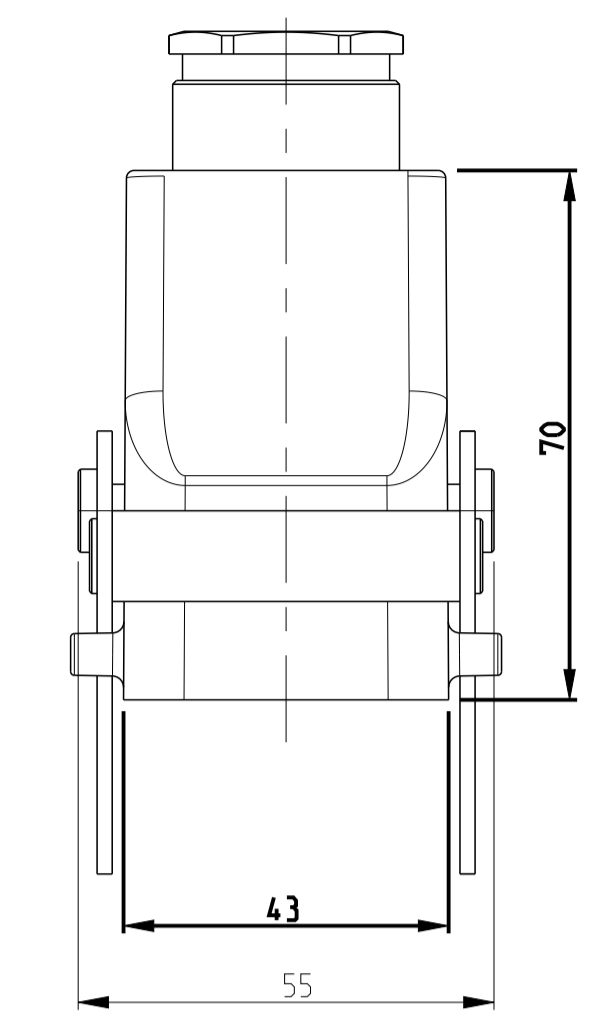

- NOTES.
- Material:Housing:Aluminium Diecasting Alloy
  - Surface:Varnish grey
  - Varnish on the inside not necessary
  - Packaging  
Quantity 5 Pieces in a box

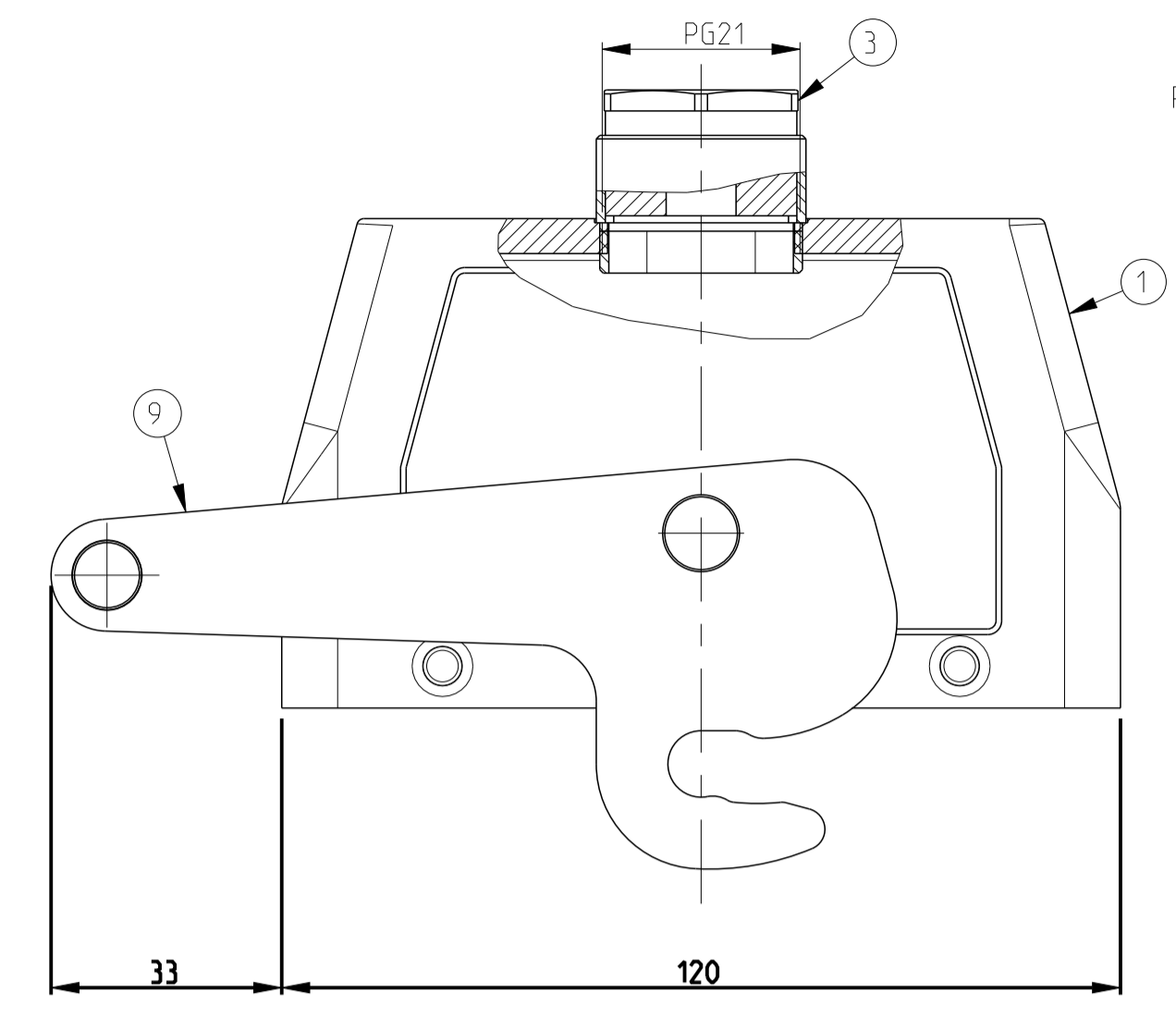
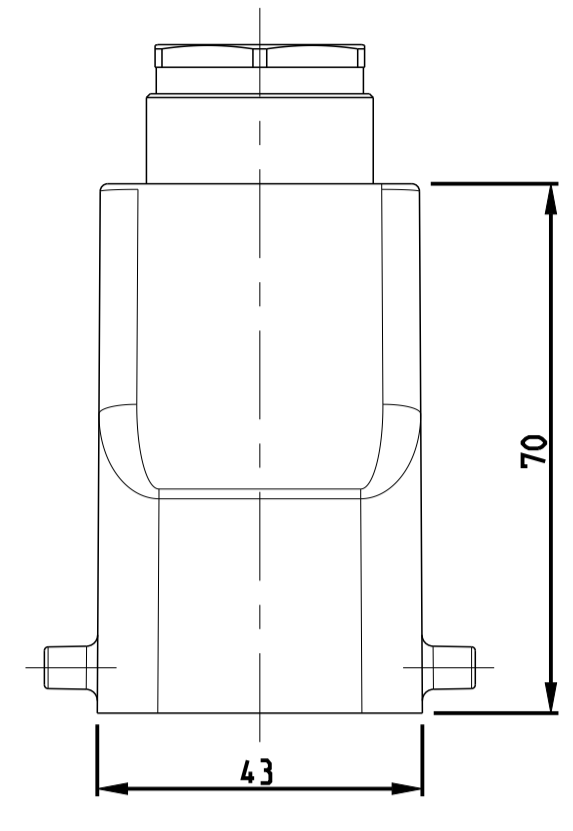
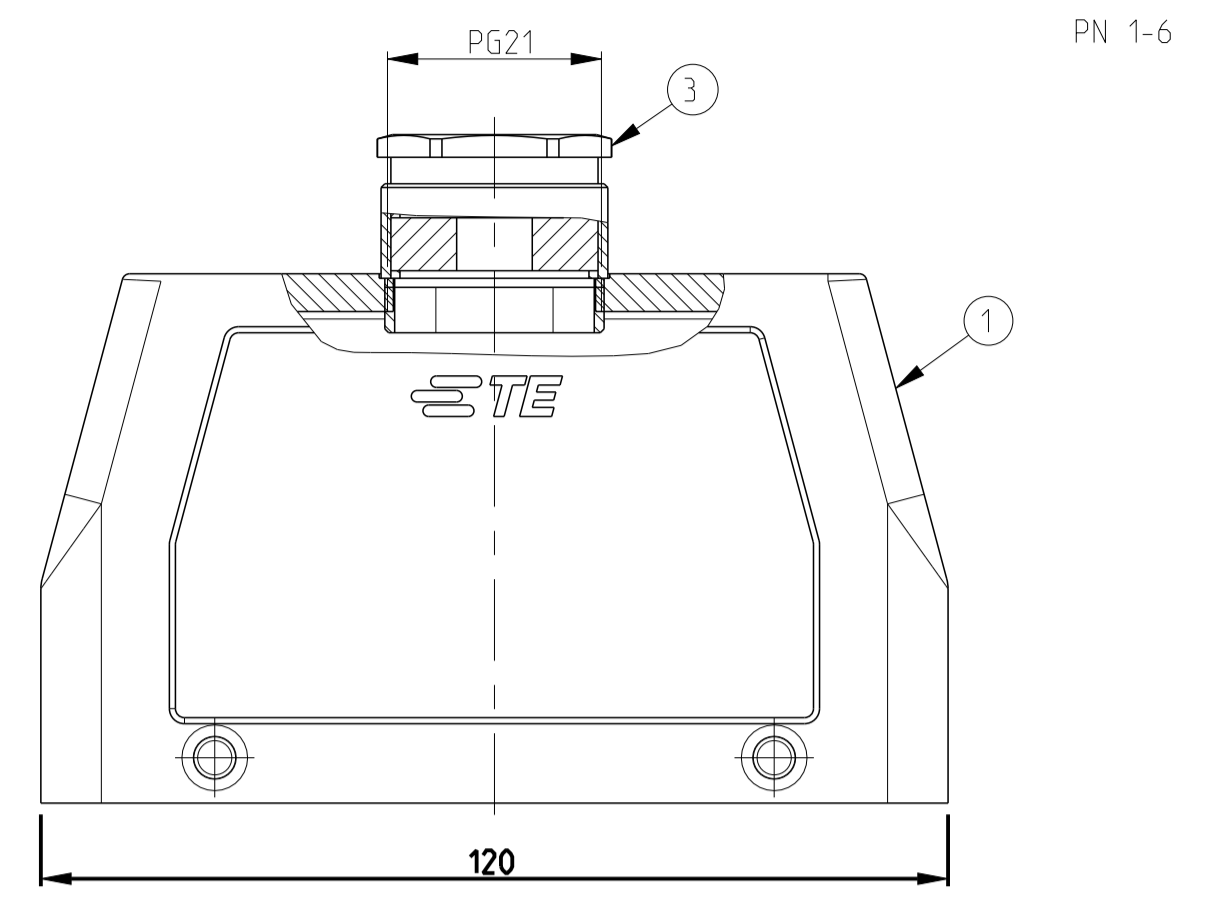
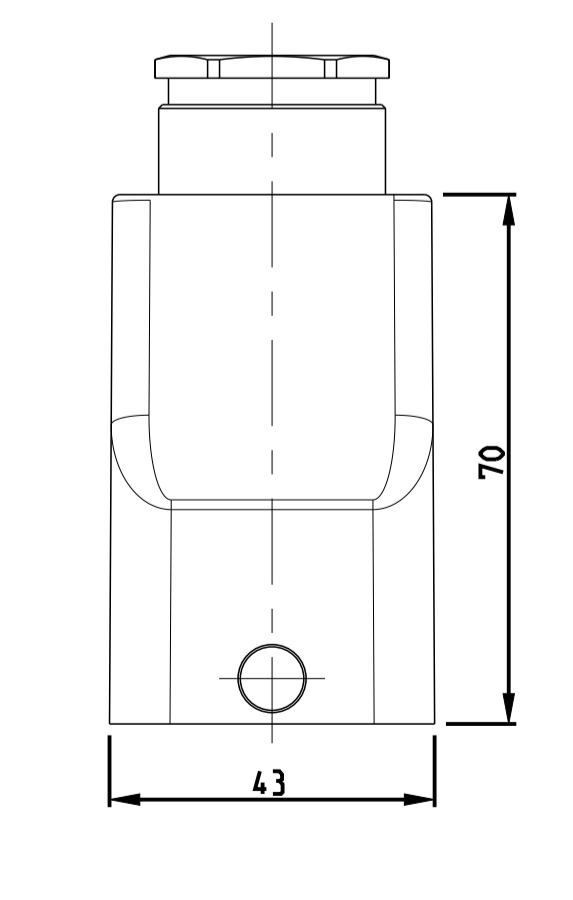
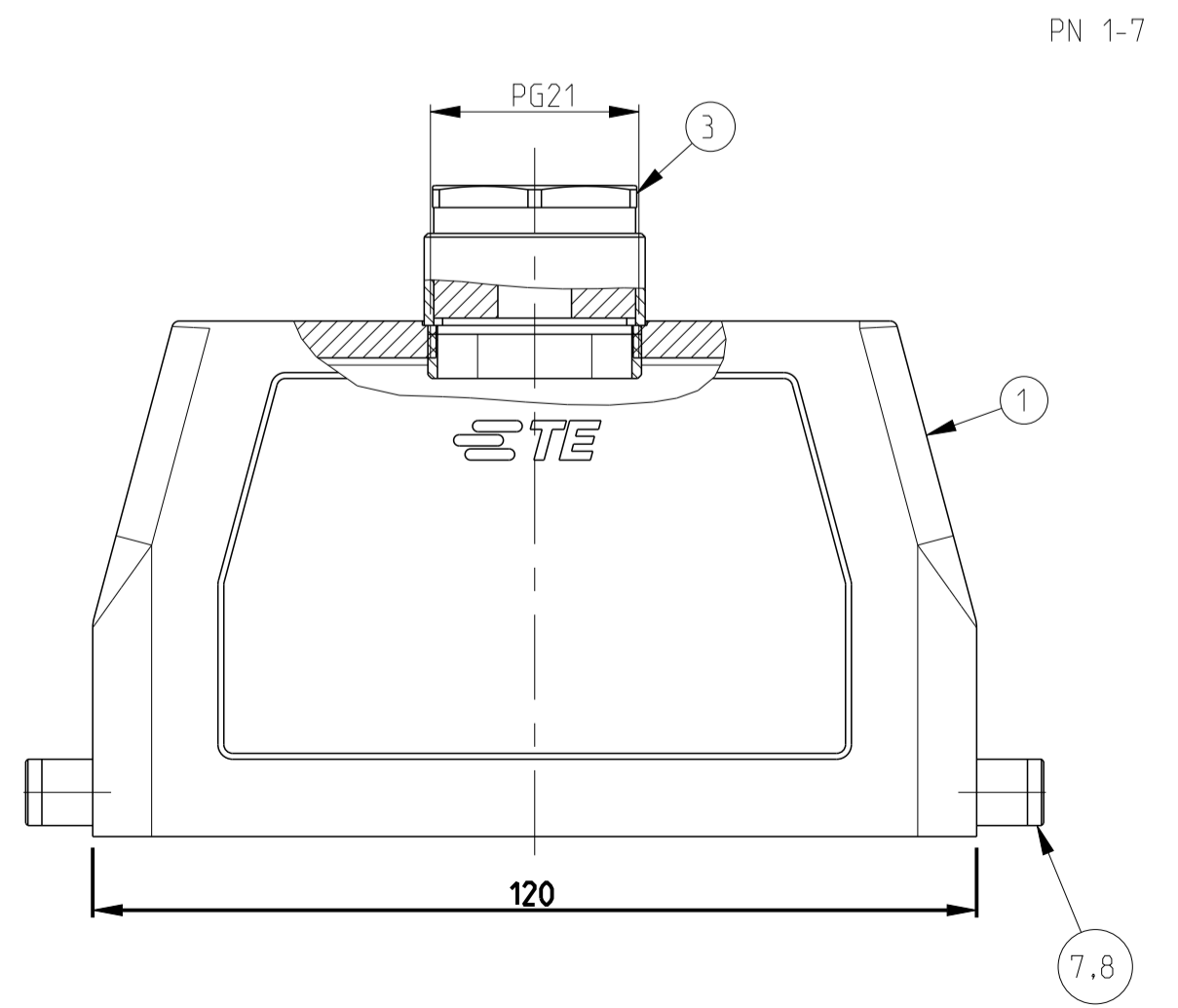
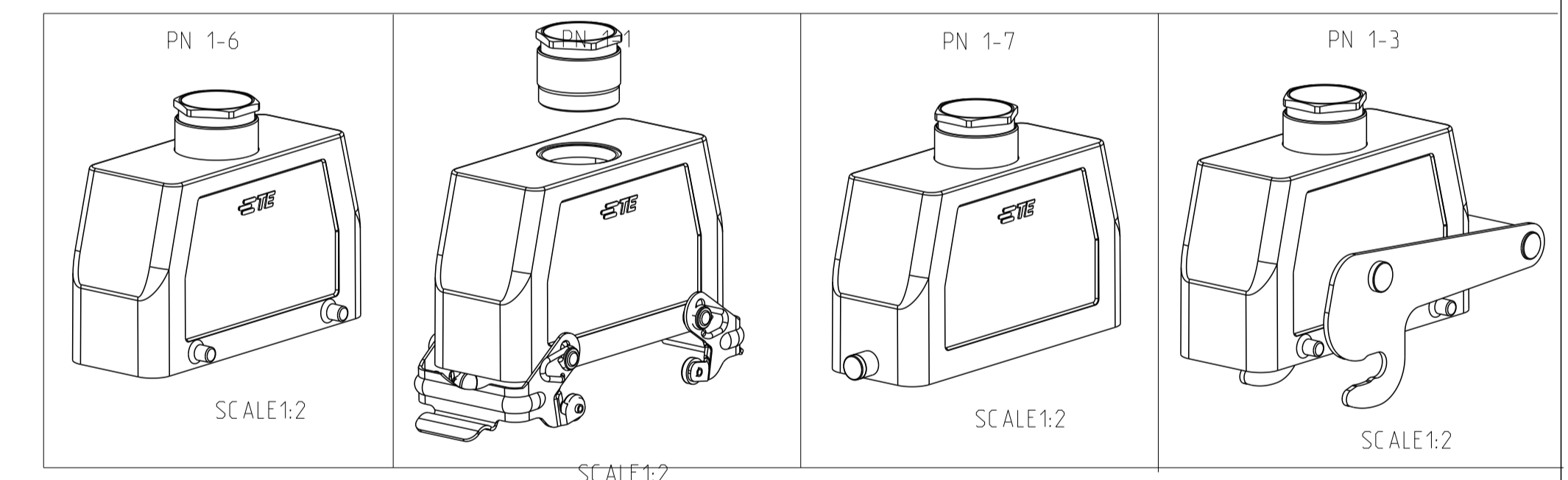
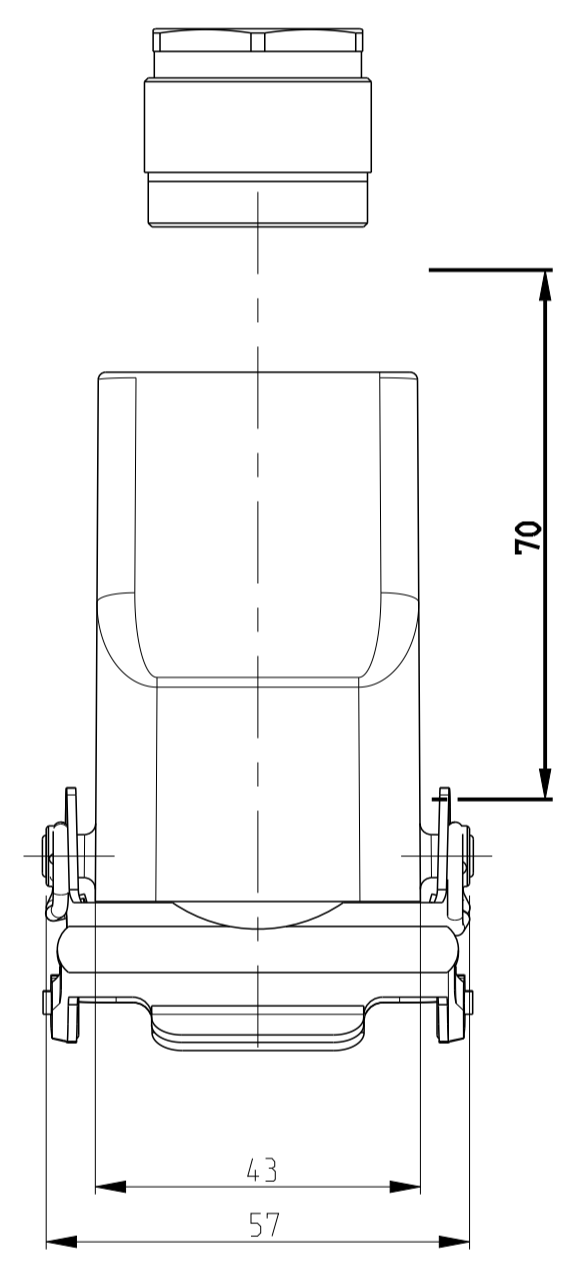
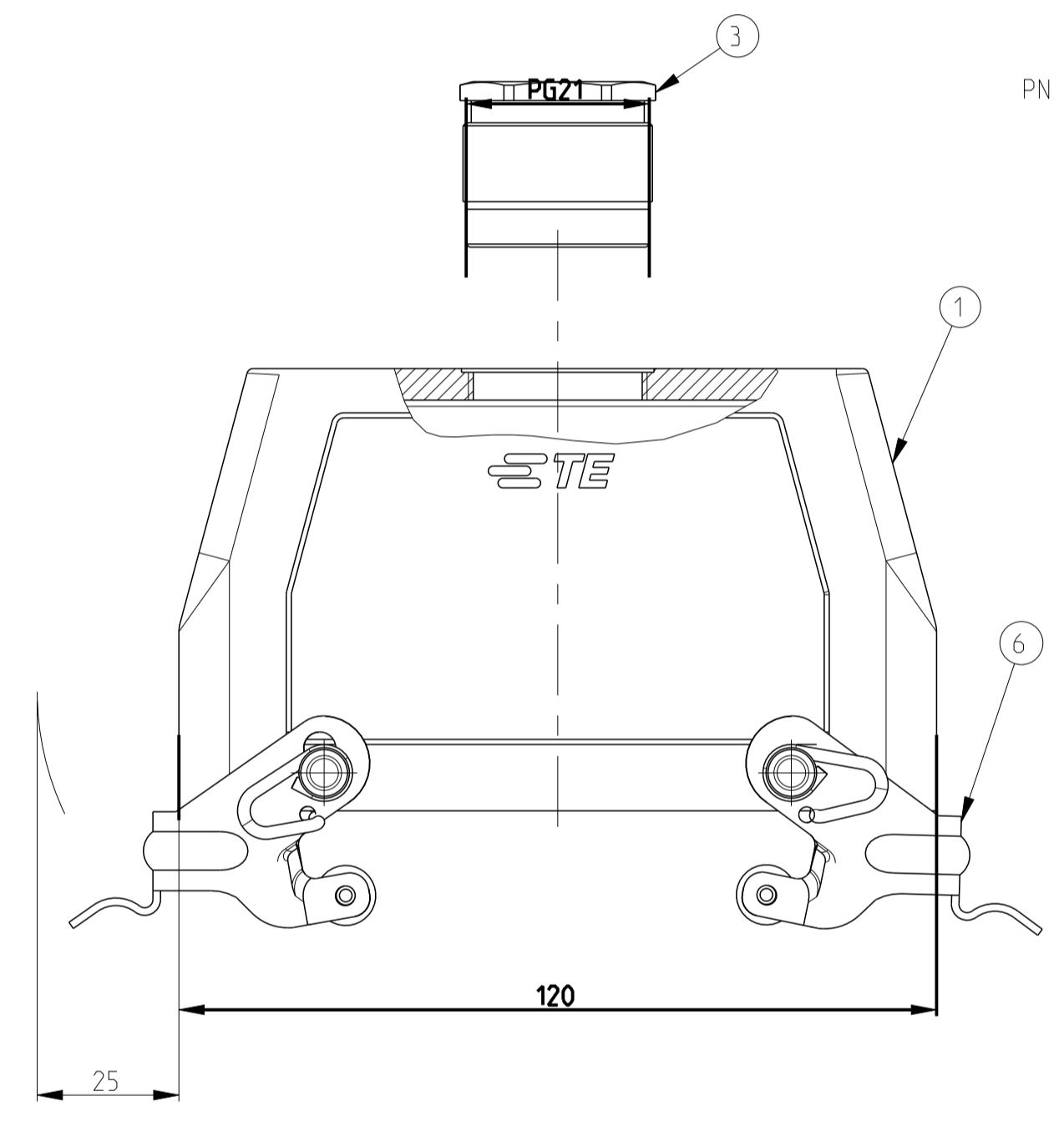

QTY	DESCRIPTION	MATERIAL	SURFACE	COLOR	ITEM NO	REMARKS
1	ZB-Central clip	Steel	Zinc plated	Blue	9	
2	LB-Clip bolt	Stainless steel	-	-	8	
2	LS-Clip bolt	Steel	Zinc plated	Blue	7	
2	VS-Locking clip	Steel	Zinc plated	Blue	6	
4	VS-Clip bolt	Stainless steel	-	-	5	
1	Hut Gland fitting Pg21	Brass	Nickel plated	-	4	
1	PG Gland fitting Pg21	Brass	Nickel plated	-	3	
1	HB Hood .24.Sto.1.21	Aluminium	Aluminium oxide	Black	2	
1	HB Hood .24.Sto.1.21	Aluminium	-	Grey	1	

ORDERING TEXT

HB-21.STO-1.21  
 HB-K-24.STO-1.21  
 HB-24.STO-VS-1.21  
 HB-24.STO-GR-1.21  
 HB-K.STO-GR-1.21  
 HB-Z-24.STO-ZB-1.21

THIS DRAWING IS A CONTROLLED DOCUMENT.

OWN: Schneider 31.07.2000  
 CHK: Schneider 31.07.2000  
 APVD: Schneider

DIMENSIONS: mm

TOLERANCES UNLESS OTHERWISE SPECIFIED:  
 0 TO 1000: ±0.1  
 1000 TO 10000: ±0.2  
 10000 TO 100000: ±0.3  
 ANGLES: ±0.5

MATERIAL: FINISH

NAME: Hood HB.24.STO.1.21

PRODUCT SPEC: 108-74.003

APPLICATION SPEC: 116-74.004

WEIGHT: -

CUSTOMER DRAWING

SCALE: 1:1 SHEET 1 OF 1 REV: A6