



025 Series Connector 1Row

1. SCOPE

1.1 Contents

This specification covers the requirements for product performance, test methods and quality assurance provisions of 025 Series Connector 1Row. Applicable product description and part numbers are as shown in Appendix 1.

2. Applicable Documents

The following documents form a part of this specification to the extent specified herein.

In the event of conflict between the requirements of this specification and the product drawing, the product drawing shall take precedence.

In the event of conflict between the requirements of this specification and the referenced documents, this specification shall take precedence.

2.1 TE Specifications

- A.109-5000 Test Specification, General Requirements for Test Methods
- B.114-5250 Crimping of 025 Contacts, Receptacle
 - 114-5217 Crimping of 040III Unsealed Contacts, Receptacle
- C.501-5318 Qualification Test Report

2.2 Commercial Standards and Specifications

- A. JASO D605 Multi-pole Connector for Automobiles.
- B. JASO D7101 Test Method for Plastic Molded Parts
- C. JIS C3406 Low Voltage Wires and Cables for Automobiles.
- D. JIS D0203 Method of moisture Rain on spray Test for Automobile-Parts.
- E. JIS D0204 Method of High and Low Temperature Test for Automobile Parts.
- F. JIS D1601 Vibration Testing Method for Automobile-Parts.
- G. JIS R5210 Portland Cement

3. Requirements

3.1 Design and Construction

Product shall be of the design, construction and physical dimensions specified on the applicable product drawing.

3.2 Materials

A. Terminals;

Description	Material	Finish
Tab(Male)	Brass	Pre-tinned or Selective-tin
Receptacle(Female)	Copper Alloy	Pre-tinned

Fig.1

B. Housing; PBT or SPS

3.3 Ratings;

A. Temperature rating;-30°C~100°C

3.4 Performance Requirements and Test Descriptions

The product shall be designed to meet the electrical, mechanical and environmental performance requirements specified in Fig.2. All tests shall be performed in the room temperature, unless otherwise specified.

3.5 Test Requirements and Procedures Summary;

Para.	Test Items	Requirements	Procedures
3.5.1	Examination of Product	Meets requirements of product drawing and TE Specification 114-5127,5250	Visually inspection. No physical damages.
Electric Requirements			
3.5.2	Termination Resistance (Specified Current)	5m Ω Max.(Initial) 10m Ω Max.(Final)	Measure mill drop of contact in mated connectors, Fig.4. TE SPEC 109-5311-2
3.5.3	Termination Resistance (Low Level)	5m Ω Max.(Initial) 10m Ω Max.(Final)	Subject mated contacts assembled in housing to 20mV MAX. open circuit at 10mA. Fig.4. TE SPEC 109-5311-1
3.5.4	Dielectric Withstanding Voltage	No creeping discharge nor flashover shall occur.	1kV A.C. for 1 minute mated connector, Fig.5. TE SPEC 109-5301
3.5.5	Insulation Resistance	100M Ω Min.(Initial/Final)	Impressed voltage 500V D.C. mated connector, Fig.5. TE SPEC 109-5302
3.5.6	Current Leakage	3mA Max.	12V D.C. for 1 minute, Fig.6. TE SPEC 109-5312
3.5.7	Temperature Rising	Temperature Rising ; 60°C Max.	Measure temperature rising at wire crimped by applied current to all positions.(Rated Current ; See Fig. 10)
3.5.8	Over Current Loading	No ignition is allowed during the test.	Apply the current to only on position. Applied current; Fig.7.
Mechanical Requirements			
3.5.9	Vibration (High Frequency)	No electrical discontinuity greater then 1 μ sec. shall occur. To meet the requirements of test examination according to test sequence on Para. 3.6	Vibration frequency;20~200~20Hz/3 minutes Accreted Velocity;44.1m/s ² Vibration Direction;X, Y and Z Duration;6 Hours Mounting; Fig.10
3.5.10	Physical Shock	No electrical discontinuity greater than 1 μ sec. shall over.	Accelerated Velocity;980 m/s ² Wave form;Half sine wave ; Fig. 7 Duration; 6 msec. Velocity Change;3.75 m/s Number of Drops; 6 drops each directions of X, Y and Z axes, totally 18 drops. TE SPEC. 109-5208 Condition D Mounting; Fig. 10
3.5.11	Connector Mating Force	69N Max.	Operation Speed;20mm/min. Measure the force required to mate connectors. TE SPEC 109-5206 Condition A

Fig.2 (To Be Continued)

Para.	Test items	Requirements		Procedures	
3.5.12	Connector Unmating Force	69N Max.		Operation speed; 100mm/min. Measure the force required to unmate connectors. (Without housing lock) TE SPEC 109-5206 Condition A	
3.5.13	Terminal Retention Force(Lance Only)	Terminal	Retention Force (N)	Apply an axial pull-off load to one of the terminals. Measure terminal retention force Operation Speed;100mm/min.	
		025	30N Min.		
3.5.14	Terminal Retention Force (Secondary Lock)	040III	40N Min.	Apply an axial pull-off load to one of the terminals. Measure terminal retention force Operation Speed;100mm/min.	
		025	100N Min.		
3.5.15	Connector Locking Strength	025	100N Min.	Apply an axial pull-off load to one of the mated housing. Measure locking strength. Operation Speed; 100mm/min TE SPEC; 109-5210.	
3.5.16	Crimp Tensile Strength	Wire Size		Apply an axial pull-off load to crimped wire of contact secured on the tester. Operation Speed;100mm/min. TE SPEC 109-5205 Condition B *;Included the insulation grip	
		Tensile Strength(N)Min.			
		mm ²	(AWG)		unit ; N
		0.3	22		70*
		0.5	20		90
		0.85	18	130	
		1.25	16	180	
3.5.17	Resistance to "Kojiri"	To meet the requirements of test examination according to test sequence on Para. 3.6		Hold one mated connectors on bench, apply repeated torque motions of 1.96N · m in front-rear and right-left directions for 10 cycles each at the every depth of 1mm graduation. This test may be alternatively performed manually. TE SPEC 109-5215	
3.5.18	Handling Ergonomics	No abnormalities allowed in manual mating/unmating handling.		Manually Operated.	
3.5.19	Retention Force of Tab	20N min. (PBT Housing) 15N min. (SPS Housing)		Measure the retention force between housing and tab contact. Operation speed:100mm/min	
3.5.20	Resistance to Soldering Heat	Application to SPS housing only. No gap with PCB and omission of screw. Retention Force of Tab : 15N Min.		Test connector is solder dipped after mounted on PCB with screw. It should be checked and measured after test connector become room temperature. Solder Temperature : 260 ± 5°C Immersion Duration : 10 ± 1sec TE spec. 109-5204 Condition B	

Fig.2 (To Be Continued)

Para.	Test items	Requirements	Procedures
3.5.21	Fasten Torque	No cracks and torsional bucklings.	Operation torque value on customer drawing.
3.5.22	solderability	Wet solder coverage : (Plated area only) 95% Min. (with substrate area) 50% Min. (without substrate area)	Solder bath : Sn-40Pb Solder temperature : $235 \pm 5^{\circ}\text{C}$ Immersion duration : $5 \pm 0.5\text{sec}$ Flux : Alpha 100 TE spec.109-5203
			Matte Tin Plating only Solder bath : Sn-3Ag-0.5Ag Solder temperature : $250 \pm 5^{\circ}\text{C}$ Immersion duration : $5 \pm 0.5\text{sec}$ Flux : ULF-300R
3.5.23	Thermal Shock	To meet the requirements of test examination according to test sequence on Para. 3.6	Mated connector $-30^{\circ}\text{C}/30\text{min.}$, $80^{\circ}\text{C}/30\text{min.}$ Making this a cycle, repeat 1000 cycles with monitoring the resistance fluctuation at 10mA. TE SPEC 109-5103
3.5.24	Humidity (Steady State)	Current Leakage; 3mA Max. To meet the requirements of test examination according to test sequence on Para. 3.6	Mated connector, 90-95% R.H 60°C 96 hours, 14V applied. TE SPEC 109-5105
3.5.25	Industrial Gas(SO ₂)	To meet the requirements of test examination according to test sequence on Para. 3.6	Unmated connector SO ₂ Gas; 25ppm, 75% R.H. 25°C , 96 hours
3.5.26	Temperature Life (Heat Aging)	To meet the requirements of test examination according to test sequence on Para. 3.6	Mated connector 100°C , 120 hours TE SPEC 109-5104
3.5.27	Resistance to Cold	To meet the requirements of test examination according to test sequence on Para. 3.6	Mated connector $-30^{\circ}\text{C} \pm 3^{\circ}\text{C}$, 120 hours TE SPEC 109-5108
3.5.28	Dust Bombardment	To meet the requirements of test examination according to test sequence on Para. 3.6	Mate connector Subject JIS R 5210 cement blow of 1.5 kg per 10 sec. in 15 minutes intervals for 8 cycles, with Unmating/Re-mating per 2 cycles. TE SPEC 109-5110

Fig.2 (To Be Continued)

3.5.29	Humidity-Temperature Cycling	To meet the requirements of test examination according to test sequence on Para. 3.6	Mated connector Fig.9, 10 cycles with monitoring the resistance fluctuation at 10mA.
3.5.30	Compound Environment Resistance	To meet the requirements of test examination according to test sequence on Para. 3.6	Mounting; See Fig.11 Test Current; See Fig.12, 300 cycles with monitoring the resistance fluctuation. Vibration Condition ; See 3.5.9 Temperature ; 80°C Duration ; 300hours Vibration Direction ; X,Y and Z
3.5.31	Dew Formation Test	To meet the requirements of test examination according to test sequence on Para. 3.6	Mated connector 0°C/10min. 80°C /30min. 90~95% R.H. Making this a cycle, repeat 48 cycles with monitoring the current leakage.

Fig.2 (End)

3.6 Product Qualification Test Sequence

Para.	Test Examination	Test Group															
		1	2	3	4	5	6	7	8	9	10	11	12	13	14	15	16
		Test Sequence															
3.5.1	Examination Of Product	1	1,5	1,9	1,9	1,5	1,11	1,11	1,6	1,6	1,6	1,3	1,5,9	1,6	1,6	1	1,3
3.5.2	Termination Resistance (Rated Current)	3	3,7	3,11	3,11		3,13	3,13	3,8	3,8	3,8		3,7,11	3,8			
3.5.3	Termination Resistance (Low Level)	2	2,6	2,10	2,10		2,12	2,12	2,7	2,7	2,7		2,6,10	2,7			
3.5.4	Dielectric Withstanding Voltage	5					5,15	5,15							3,8		
3.5.5	Insulation Resistance	4					4,14	4,14							2,7		
3.5.6	Current Leakage						10	10							5		
3.5.7	Temperature Rising			12									4	9			
3.5.8	Over Current Loading												8				
3.5.9	Vibration (High Frequency)										5			5			
3.5.10	Physical Shock											4					
3.5.11	Connector Mating Force	7															
3.5.12	Connector Unmating Force	6															
3.5.13	Terminal Retention Force (Lance Only)	8		4,14	4,13	2,7	6,17	6,17									
3.5.14	Terminal Retention Force (Secondary Lock)	9		5,15	5,14	3,8	7,18	7,18									
3.5.15	Connector Locking Strength	10		6,16	6,15		8,19	8,19									
3.5.16	Crimp Tensile Strength	13		7,17	7,16					4,9							
3.5.17	Resistance to "Kojiri"		4														
3.5.18	Handling Ergonomics			13	12	6	16	16									
3.5.19	Retention Force of Tab															2	4
3.5.20	Resistance to Soldering Heart																2
3.5.21	Fasten Torque	11															
3.5.22	Solderability	12															
3.5.23	Thermal Shock				8												
3.5.24	Humidity (Steady State)							9									
3.5.25	Industrial SO ² Gas									5							
3.5.26	Temperature Life (Heat Aging)			8					4		4	2					
3.5.27	Resistance to Cold					4											
3.5.28	Dust Bombardment								5								
3.5.29	Humidity Temperature Cycling						9										
3.5.30	Compound Environment Resistance													4			
3.5.31	Dew Formation Test														4		

Fig. 3

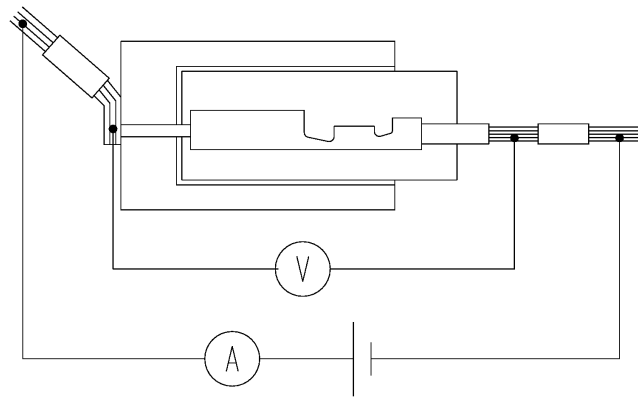

Soldering wire on stripped area.
Remove the bulk resistance from the measured value.

Fig.4

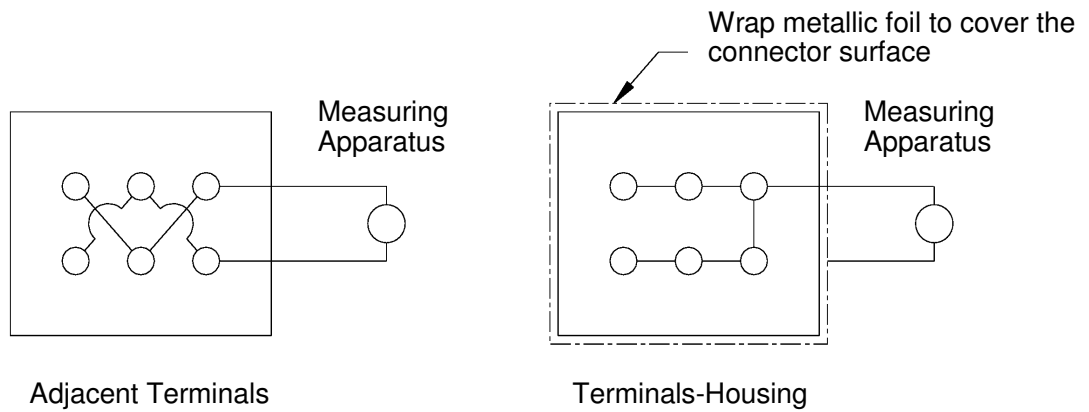

Fig.5

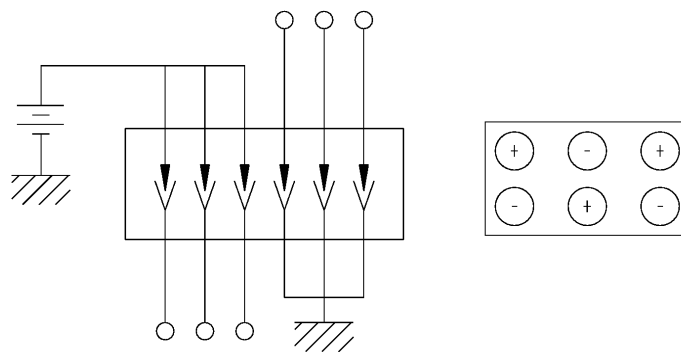

Fig.6

Wire Size (mm ²)	Test Current (A)	Duration	Wire Size (mm ²)	Test Current (A)	Duration
0.3	11	60 min.	0.85	16.5	60 min.
	13.5	10 sec.		20.2	100 sec.
	15	5 sec.		22.5	10sec.
	20	1 sec.		30	1 sec.
0.5	16.5	60 min.	1.25	16.5	60 min.
	20.2	200sec.		20.2	100sec.
	22.5	5sec.		22.5	10sec.
	30	1sec.		30	2sec.

Fig.7

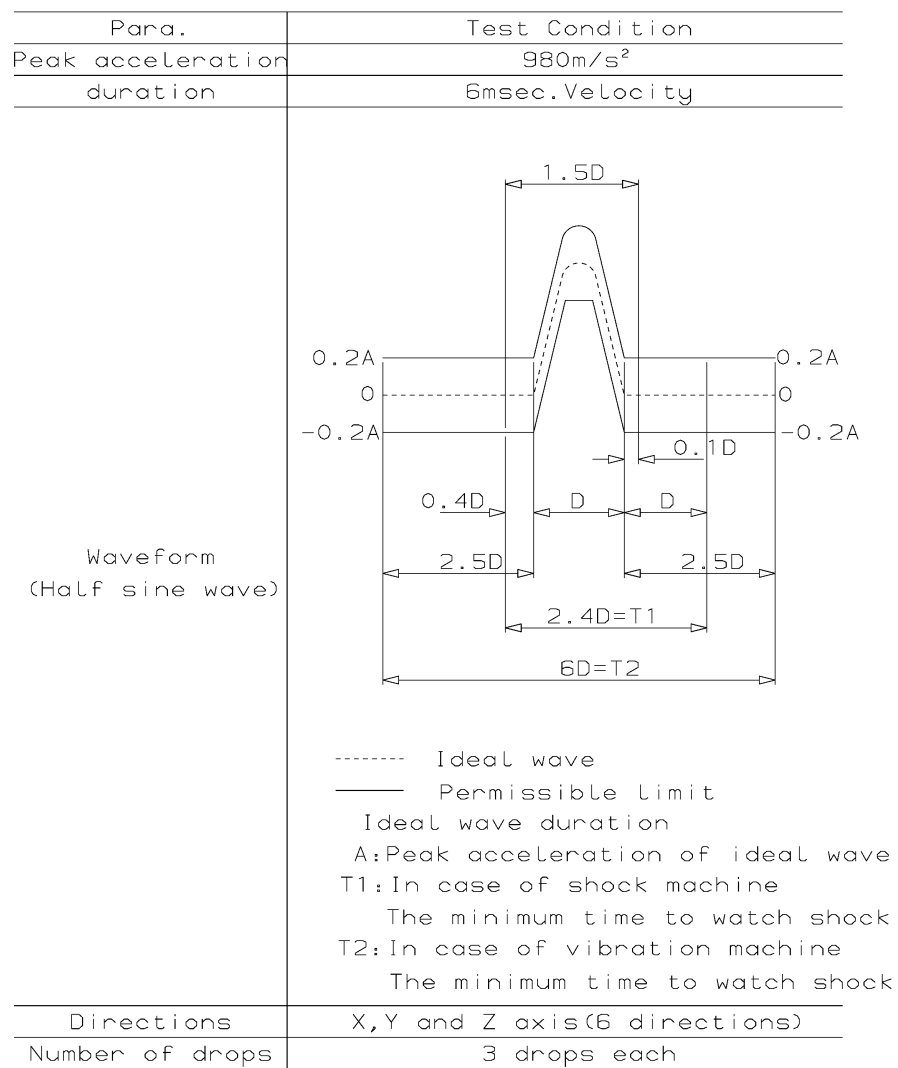

Fig.8

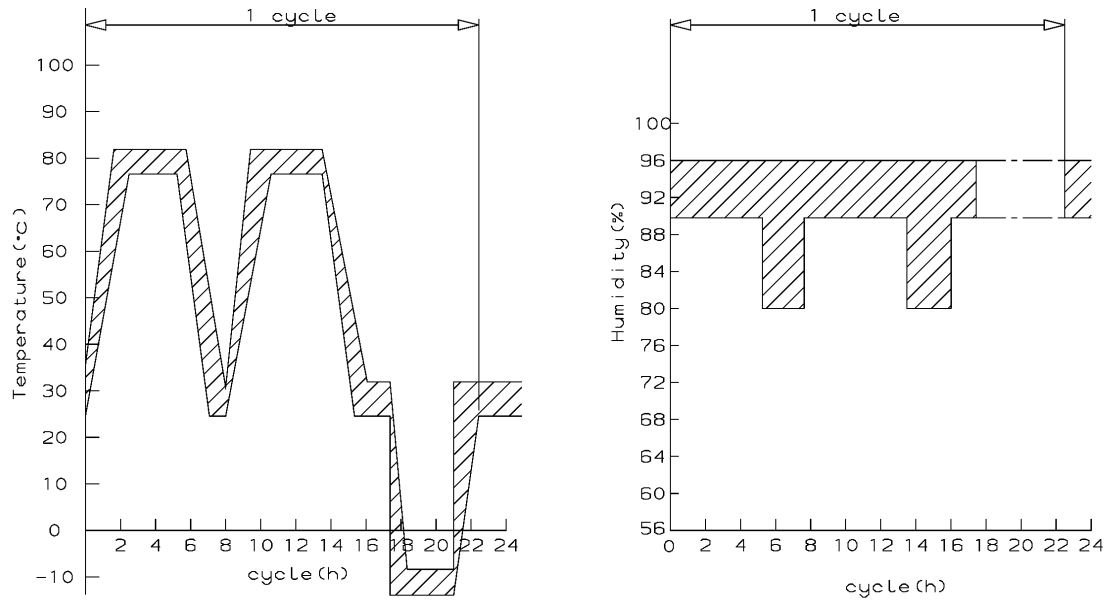

Fig.9

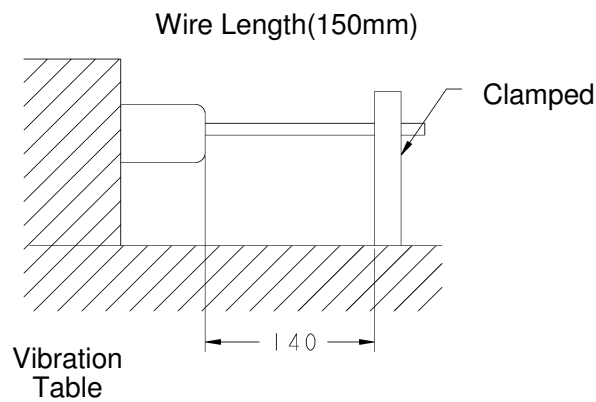

Fig.10

Terminal	Wire Size (mm ²)	Test Current (A)	Temp. Rising
040III	1.25	10.4	60°C Max.
	0.5	6.0	
025	0.3	2.2	

Fig.11

Terminal	Wire Size (mm ²)	Test Current (A)	Duration
040III	1.25	5.5	45Min. ON 15Min. OFF
	0.5	3.3	
025	0.5	2.2	

Fig.12

Part Number	Description
1318801	025/040 7P Immobilizer Plug Housing
1376366	025 8P Cap Housing Assembly
1747285	0.64 8P Cap Housing Assembly (SPS)
1376368	025 8P Plug Housing
1565749	025 4P Cap Housing Assembly
1473672	025 4P Plug Housing
316836	040 III Receptacle Contact (S)
316838	040 III Receptacle Contact (M)
1123343	025 Receptacle Contact

Appendix.1

*Note: Part number is consisted from listed base number and 1 digit numeric prefix and Suffix with dash. Refer to catalog or customer drawing for specific part numbers for each base number. When prefix is zero, zero and dash are omitted.