

PRODUCT SPECIFICATION

1. SCOPE

1.1. Content

This specification covers the performance, tests and quality requirements for the AMP* audio microphone connector. These connector assemblies are interchangeable with standard DIN-MAK-40 connectors now in use.

1.2. Qualification

When tests are performed on the subject product line, the procedures specified in AMP 109 series specifications shall be used. All inspections shall be performed using the applicable inspection plan and product drawing.

2. APPLICABLE DOCUMENTS

The following documents form a part of this specification to the extent specified herein. In the event of conflict between the requirements of this specification and the product drawing, the product drawing shall take precedence. In the event of conflict between the requirements of this specification and the referenced documents, this specification shall take precedence.

2.1. AMP Specifications

- A. 109-1: General Requirements for Test Specifications
- B. 109 Series: Test Specifications as indicated in Figure 1.
(Comply with MIL-STD-202, MIL-STD-1344 and EIA RS-364)
- C. 114-10011: Connector, Microphone, Audio, Application of

3. REQUIREMENTS

3.1. Design and Construction

Connector shall be of the design, construction and physical dimensions specified on the applicable product drawing.

*Trademark of AMP Incorporated.

©COPYRIGHT 1976, 82
 BY AMP INCORPORATED, HARRISBURG, PA. ALL INTERNATIONAL
 RIGHTS RESERVED. AMP PRODUCTS MAY BE COVERED BY U.S. AND
 FOREIGN PATENTS AND/OR PATENTS PENDING.

				DR <i>Fred Rendall</i> 8/7/82	 AMP INCORPORATED Harrisburg, Pa. 17105			
				CHK <i>Dan Eaby</i> 8/6/82				
				APP <i>Joseph L. Taylor</i> 8/6/82		LOC B	NO 108-10032	REV 0
				TITLE CONNECTOR, MICROPHONE, AUDIO				
DIST 10	0	Release per ECN J-654		SHEET 1 OF 6				
LTR	REVISION RECORD		APP	DATE				

3.2. Materials

- A. Contact: Brass, tin plated or gold over nickel
- B. Housing: Nylon, UL 94V-0

3.3. Ratings

- A. Current/Voltage: 250 vac at 10 amperes maximum test current in free air
- B. Operating Temperature: -55° to 105°C

3.4. Performance and Test Description

Connector shall be designed to meet the electrical, mechanical and environmental performance requirements specified in Figure 1.

3.5. Test Requirements and Procedures Summary

Test Description	Requirement	Procedure
Examination of Product	Meets requirements of product drawing and applicable AMP Spec 114-10011.	Visual, dimensional and functional per applicable inspection plan.
ELECTRICAL		
Dielectric Withstanding Voltage	1000 vac (rms) dielectric withstanding voltage, one minute hold.	Test between adjacent contacts of unmated connector assemblies; AMP Spec 109-29-1.
Insulation Resistance	5×10^3 megohms minimum initial.	Test between adjacent contacts of unmated connector assembly; AMP Spec 109-28-4.
MECHANICAL		
Vibration (a)	No discontinuities greater than 1 microsecond.	Subject mated connectors to 15 G's, 10-2000 Hz with 100 ma current applied; AMP Spec 109-21-3.
Physical Shock (a)	No discontinuities greater than 1 microsecond.	Subject mated connectors to 50 G's halfsine in 11 milliseconds; 6 shocks in Z axis and 6 shocks in Y axis total 12 shocks; AMP Spec 109-26-1, see Figure 3.

Figure 1 (cont)

AMP	AMP INCORPORATED Harrisburg, Pa. 17105	LOC	SHEET	NO	REV
		B	2 OF 6	108-10032	0

Test Description	Requirement	Procedure
Mating Force	3 inch pounds maximum.	Measure force necessary to mate connector assembly; AMP Spec 109-42, cond B.
Unmating Force	3 inch pounds maximum.	Measure force necessary to unmate connector assembly; AMP Spec 109-42, cond B.
Contact Retention	6 pounds minimum per contact. Shall not dislodge or damage contact, connector or retention mechanism.	Apply axial load of 6 pounds to mating end of each individual contact, insert and remove contacts 2 times before test; AMP Spec 109-30.
Cable Pull-Out	No loss of electrical continuity; cable shall not exceed .250 inch longitudinal displacement.	Subject mated connectors to 15 pound pull with 100 milliamperes current flowing through all series contacts; AMP Spec 109-46, cond Z.
Durability	Force to mate and unmate connector on first, 100 and last cycle shall not exceed 3 inch pounds; connectors shall show electrical continuity when fully mated on every cycle.	Manually mate and unmate connector assemblies for 250 cycles, at a rate of 500 cycles/hour, with 100 milliamperes current flowing through all series contacts; AMP Spec 109-27.
Flex	There shall be no open circuits during testing. Connector plug shall not have worked loose and neither the cord guard nor the cable shall show any damage.	Subject mated connectors to 2500 cycles or 5000 flexing at a rate of 60 flexing/minute; all individual circuits shall be electrically energized, a 1 pound weight shall be attached to the free end of the cable, see Figure 3.

ENVIRONMENTAL

Thermal Shock (a)	Dielectric withstanding voltage.	Subject unmated connectors to 10 cycles between -55° and 105°C; AMP Spec 109-22.
-------------------	----------------------------------	--

Figure 1 (cont)

AMP	AMP INCORPORATED Harrisburg, Pa. 17105	LOC	SHEET	NO	REV
		B	3 OF 6	108-10032	0

Test Description	Requirement	Procedure
Humidity, Steady State	10 megohms minimum final, insulation resistance.	Subject unmated connectors to steady state humidity at 40°C and 90-95% RH; AMP Spec 109-23, method II, cond B.

(a) Shall remain mated and show no evidence of damage, cracking or chipping.

Figure 1 (end)

3.6. Connector Tests and Sequences

Test or Examination	Test Group (a)			
	1	2	3	4
	Test Sequence (b)			
Examination of Product	1,5	1,7	1,7	1,8
Dielectric Withstanding Voltage	3	3	3	
Insulation Resistance	2	2,5		
Vibration			4	
Physical Shock			5	
Mating Force				2,5
Unmating Force				3,6
Contact Retention				7
Cable Pull-Out		6	6	
Durability				4
Flex	4			
Thermal Shock (a)			2	
Humidity, Steady State		4		

(a) See Para 4.1.A.

(b) Numbers indicate sequence in which tests are performed.

Figure 2

AMP	AMP INCORPORATED Harrisburg, Pa. 17105	LOC	SHEET	NO	REV
		B	4 OF 6	108-10032	0

4. QUALITY ASSURANCE PROVISIONS

4.1. Qualification Testing

A. Sample Selection

Connector housings and contacts shall be prepared in accordance with applicable Instruction Sheets. They shall be selected at random from current production. All test groups shall consist of 2 mating pairs of fully assembled connectors. All contacts shall be crimped to 2 feet of cable in accordance with AMP Specification 114-10011.

B. Test Sequence

Qualification inspection shall be verified by testing samples as specified in Figure 2.

C. Acceptance

- (1) All samples tested in accordance with this specification shall meet the stated tolerance limit.
- (2) Failures attributed to equipment, test setup, or operator deficiencies shall not disqualify the product. When product failure occurs, corrective action shall be taken and samples resubmitted for qualification.

4.2. Quality Conformance Inspection

The applicable AMP inspection plan will specify the sampling acceptable quality level to be used. Dimensional and functional requirements shall be in accordance with the applicable product drawing and this specification.

AMP

AMP INCORPORATED
Harrisburg, Pa. 17105

LOC
B

SHEET
5 OF 6

NO
108-10032

REV
0

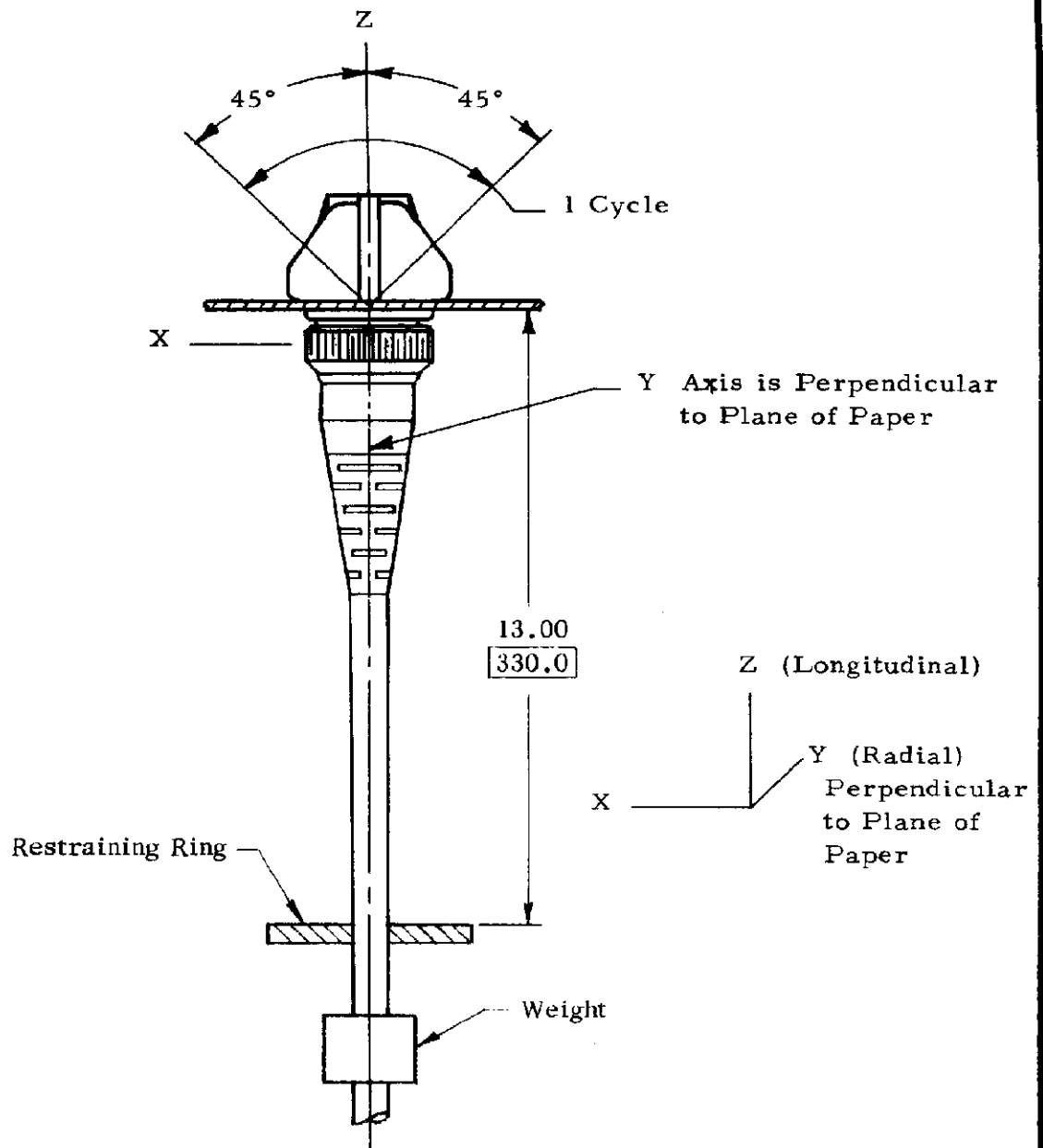

Note: Samples shall be conditioned in air circulating oven at a temperature of 105°C for 24 hours. Samples shall then be cooled for one-half hour maximum, at ambient, before test.

Figure 3

Flex Test

AMP

AMP INCORPORATED
Harrisburg, Pa. 17105

LOC
B

SHEET
6 OF 6

NO
108-10032

REV
0