

THIS DRAWING IS UNPUBLISHED. RELEASED FOR PUBLICATION
 © COPYRIGHT BY TYCO ELECTRONICS CORPORATION. ALL INTERNATIONAL RIGHTS RESERVED.

LOC		DIST		REVISIONS			
P	LTR	DESCRIPTION		DATE	DWN	APVD	
	B	REV PER ECO-08-021971		30DEC08	PY	WM	

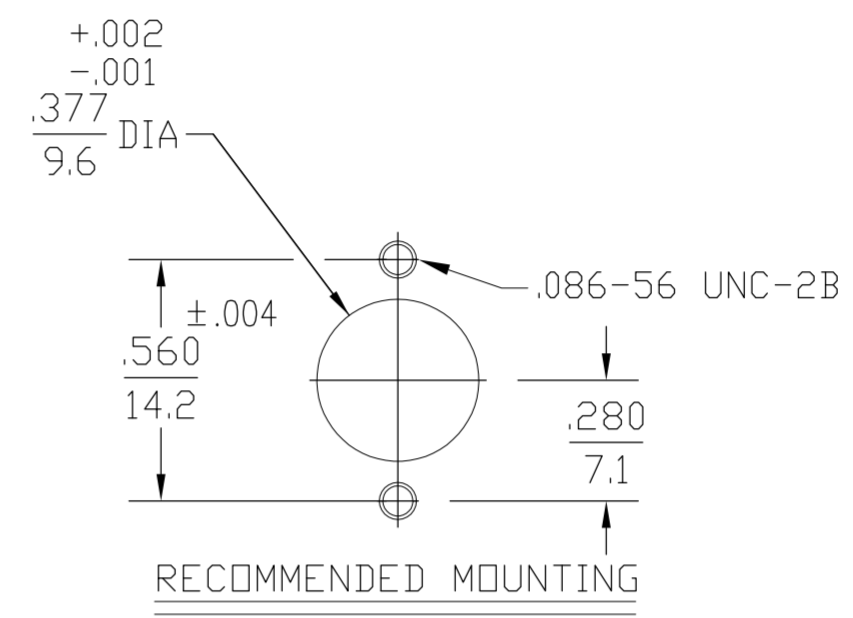
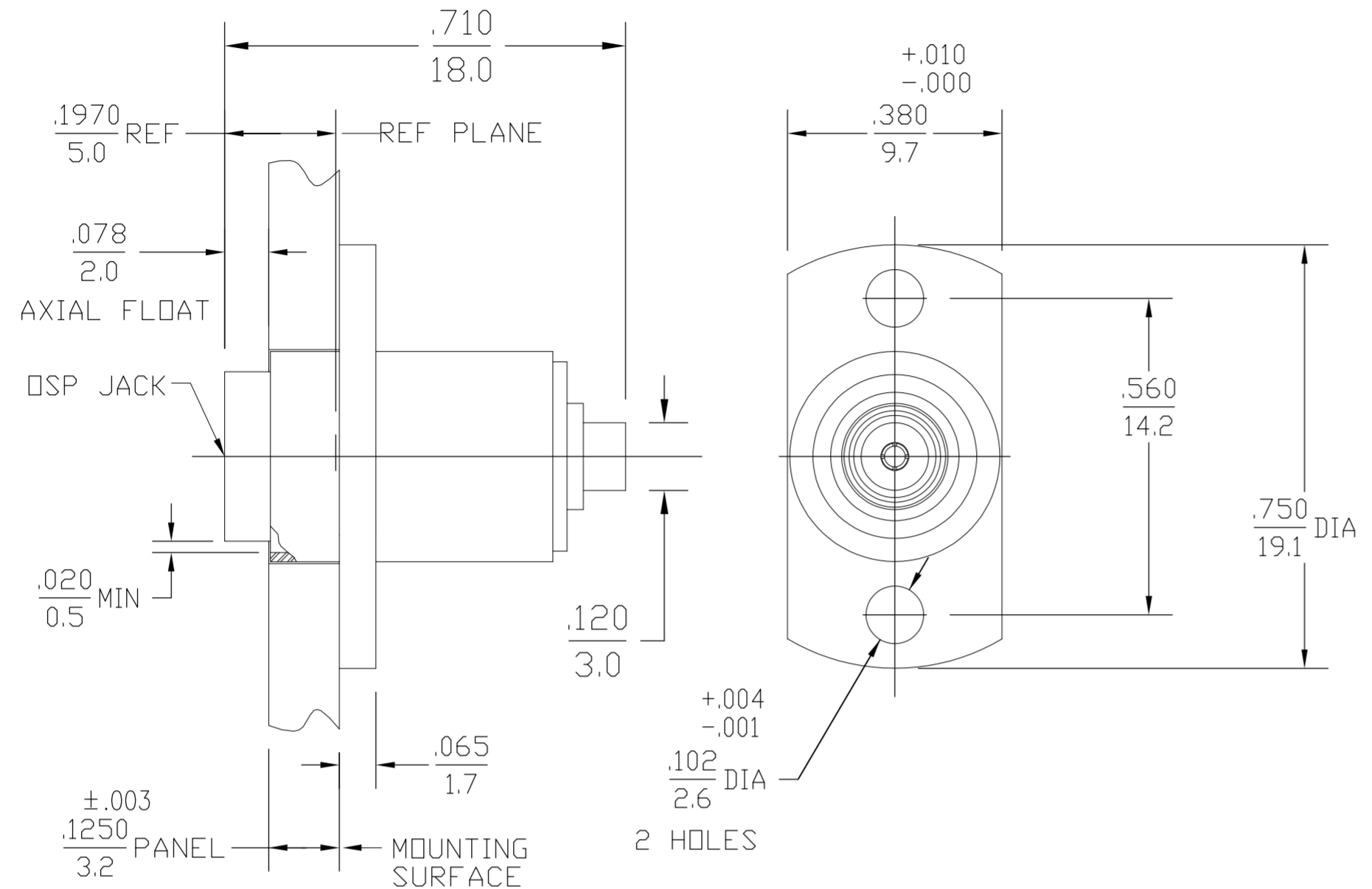

DESIGNED FOR USE WITH .085 DIA SEMI-RIGID CABLE CABLE ENTRY DIAMETER MINIMUM	
HOUSING	.089
CONTACT	.021

ELECTRICAL	MECHANICAL	ENVIRONMENTAL
Nominal Impedance (Ohms) 50	Interface Dimensions MIL-STD-348A, FIG 321-2	TEMPERATURE RATING -65° TO +125°C
Frequency Range (GHz) DC to 18	Mating Characteristics:	Vibration MIL-STD-202, Method 204, Condition D
Volt Rating (VRMS MAX) @ Sea Level 335	Insertion (MAX Lbs) 3	Shock MIL-STD-202, Method 213, Condition I
VSWR 1.05+.005f(GHz) DC to 18 GHz	Withdrawal (MIN Oz) 1	Thermal Shock MIL-STD-202, Method 107, Condition B
Insertion Loss (dB MAX) .03x√f(GHz)	Force to Engage (In-Lbs MAX) & Disengage (In-Lbs MAX) 3 & 1.5	Moisture Resistance MIL-STD-202, Method 106
RF Leakage (dB MIN) (Interface Only, Fully Mated) -(90-f(GHz))	Center Contact Captivation Axial (Lbs) 6	Corrosion - MIL-STD-202, Method 101, Condition B, 5% Salt Spray
Corona, 70,000 Ft (VRMS MIN) 335	Cable Retention Axial Force (Lbs MIN) 30	
Dielectric Withstanding Voltage (VRMS MIN) @ Sea Level 1000	Torque (In-Oz MIN) 16	
Contact Resistance (Milliohms MAX)	Weight (Grams) 5.4	
Center Contact 2.0		
Outer Contact 2.0		
Cable to Housing 0.5		
RF High Potential @ Sea Level (VRMS MIN @ 5 MHz) 670		
I.R.(Megohms MIN) 5000		

COMPONENT	MATERIAL	FINISH
INNER HOUSING BUSHING	STAINLESS STEEL PER ASTM-A484 AND ASTM-A582, TYPE 303	GOLD PLATE PER MIL-G-45204 OVER NICKEL PLATE PER QQ-N-290
OUTER HOUSING SPRING WASHER	STAINLESS STEEL PER ASTM-A484 AND ASTM-A582, TYPE 303	PASSIVATE PER ASTM-A380
DIELECTRIC	TFE FLUOROCARBON PER ASTM-D-1457	N/A
CENTER CONTACT CONTACT SLEEVE	BERYLLIUM COPPER PER ASTM B 196, ALLOY C17300, CONDITION H	GOLD PLATE PER MIL-G-45204 OVER COPPER PLATE PER MIL-C-14550
CONTACT RING RETAINING RING SPRING WASHER	BERYLLIUM COPPER PER ASTM B 194, ALLOY C17200, CONDITION H	GOLD PLATE PER MIL-G-45204 OVER COPPER PLATE PER MIL-C-14550
COMP. SPRING	STAINLESS STEEL	PASSIVATE PER QQ-P-35

THIS DRAWING IS A CONTROLLED DOCUMENT.

DWN P. YEAGER 29DEC2008	Tyco Electronics Corporation Harrisburg, PA 17105-3608		
CHK W. MOYER 30DEC08			
APVD W. MOYER 30DEC08			
PRODUCT SPEC			
NAME		OSP FLOATING FLANGE MOUNT CABLE JACK - DIRECT SOLDER ATTACHMENT	
APPLICATION SPEC		SIZE A2	CAGE CODE 00779
WEIGHT -		DRAWING NO C=1059426	RESTRICTED TO -
CUSTOMER DRAWING		SCALE 4:1	SHEET 1 of 1