

WARNING - THIS DOCUMENT CONTAINS TECHNOLOGY WHOSE EXPORT IS RESTRICTED BY THE EXPORT ADMINISTRATION REGULATIONS ("EAR") PURSUANT TO 15 C.F.R. PARTS 730-774. VIOLATIONS OF THE EAR ARE SUBJECT TO SEVERE CRIMINAL PENALTIES UNDER THE EXPORT CONTROL REFORM ACT, AS AMENDED (TITLE 50, U.S.C., SEC. 4801, ET SEQ.).

REVISIONS				
P	LTR	DESCRIPTION	DATE	APVD
	M	REV PER ECN-24-284433	18SEP2024	LP JG

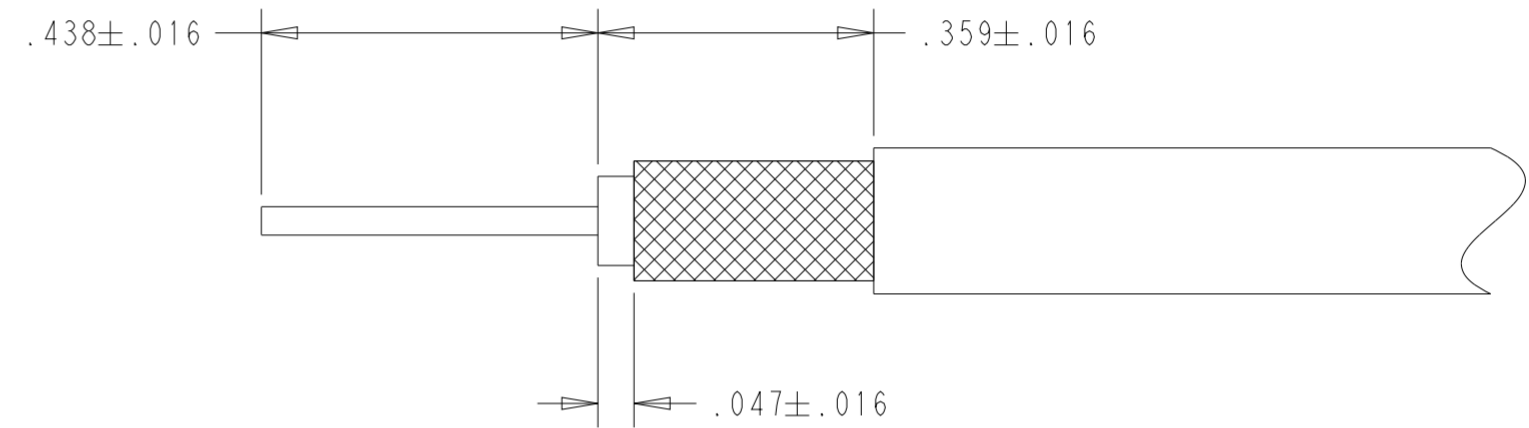

RECOMMENDED STRIP PREPARATION

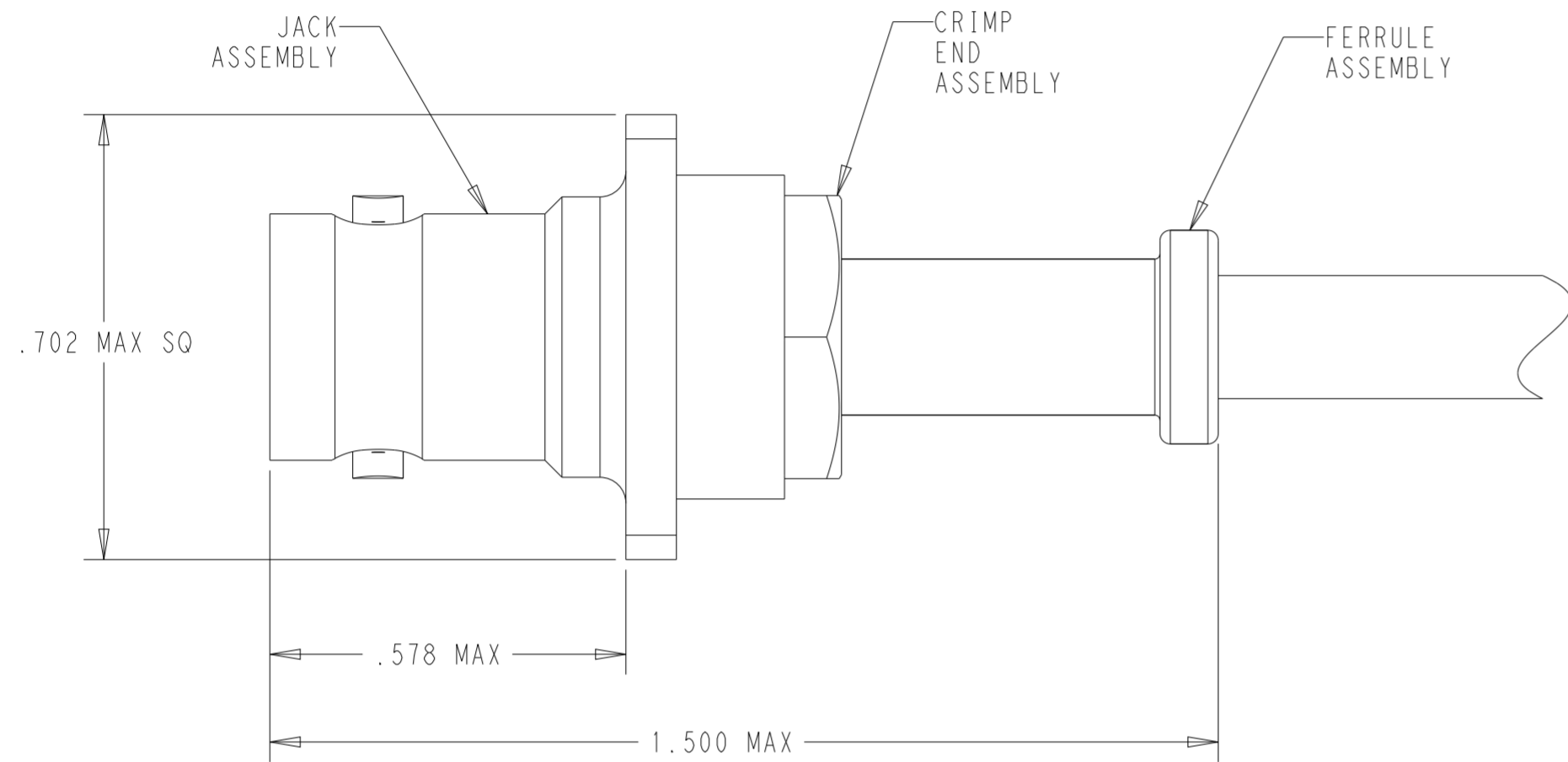
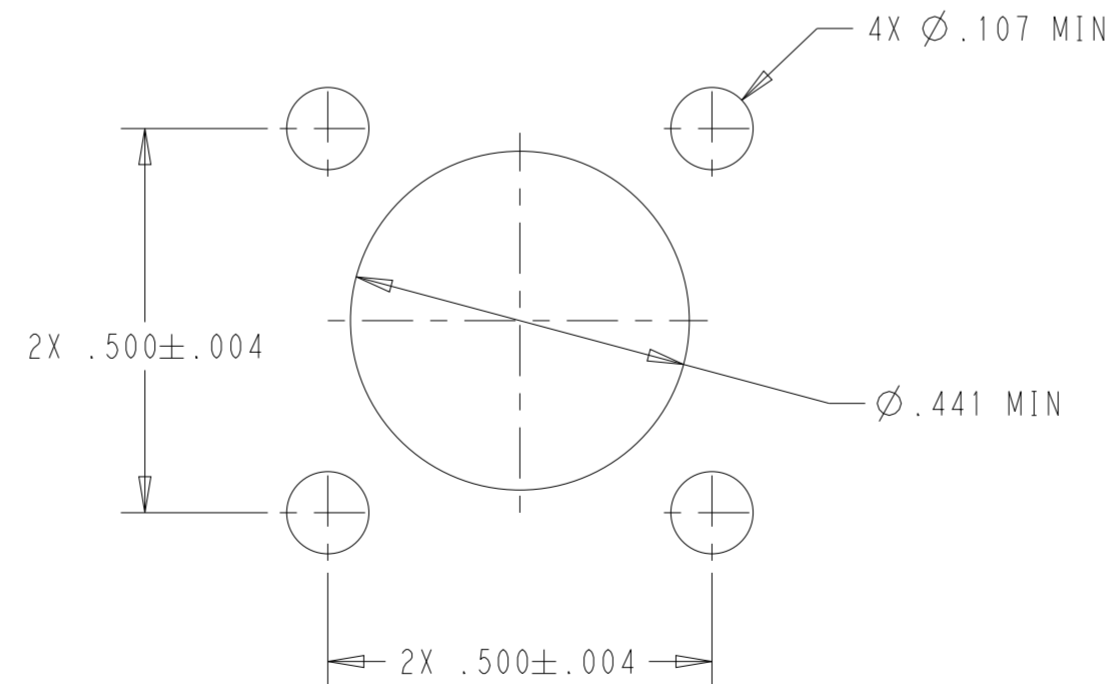

PANEL CUTOUT

SHELLS	BRASS PER ASTM B16	SILVER PLATE PER ASTM B700
DIELECTRICS	PTFE FLUOROCARBON PER ASTM-D-1457	N/A
GASKETS	SILICONE RUBBER PER A-A-59588	N/A
CONTACT	BeCu PER ASTM B196	GOLD PLATE PER ASTM B488 OVER NICKEL PLATE PER SAE-AMS-QQ-N-290
CRIMP FERRULE	COPPER OR BRASS ALLOY ROCKWELL B 45 MAX	SILVER PLATE PER ASTM B700
FLANGE	BRASS PER ASTM B36	SILVER PLATE PER ASTM B700
COMPONENT	MATERIAL	FINISH

69376-1	1-331280-1
CRIMP TOOL	PART NUMBER

- FOR USE ON CABLE SIZE RG-141/U AND 141A/U
- SEE INSTRUCTION SHEET 408-1799-4
- WEIGHT: .53 OZ

THIS DRAWING IS A CONTROLLED DOCUMENT.		DWN	06SEP2024	TE Connectivity	CONNECTOR, COAXIAL, RF, JACK, PANEL, SERIES BNC
DIMENSIONS: in		CHK	06SEP2024		
TOLERANCES UNLESS OTHERWISE SPECIFIED:		APVD	06SEP2024		
0 PLC ± 1 PLC ± 2 PLC ± 3 PLC ± 4 PLC ± ANGLES ± FINISH -		J. GUNDERMANN D. WILSON	NAME PRODUCT SPEC APPLICATION SPEC WEIGHT		
MATERIAL	-	SIZE	A2	CAGE CODE	00779
		DRAWING NO	G-1-331280-1		RESTRICTED TO
		CUSTOMER DRAWING	SCALE	4:1	SHEET 1 OF 1
					REV M