

8 7 6 5 4 3 2 1

REVISIONS					
ZONE	LTR	ECN	DESCRIPTION	DATE	APPROVED
B1			REVISED PER ECO-11-005139	28MAR11	HMR

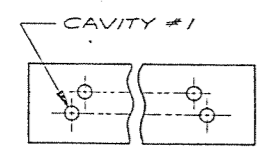

REAR VIEW OF PLUG CAVITY LAYOUT

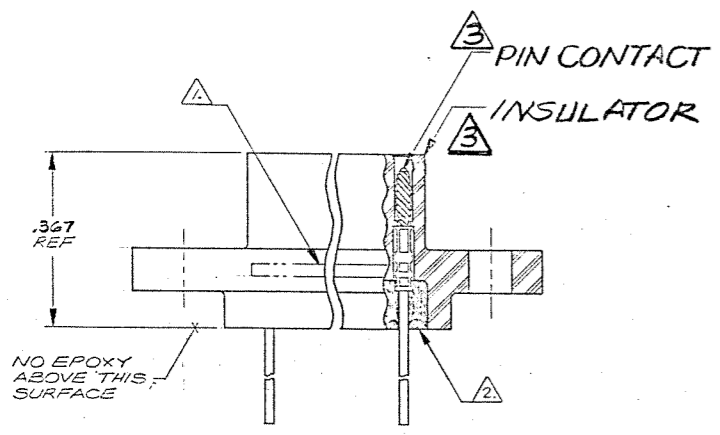
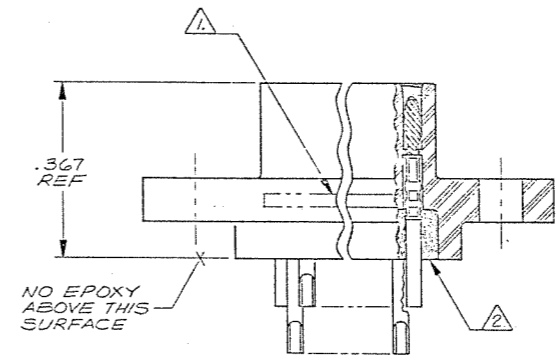
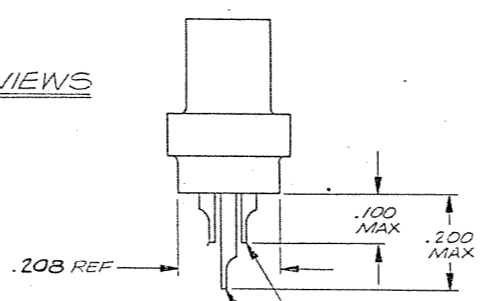
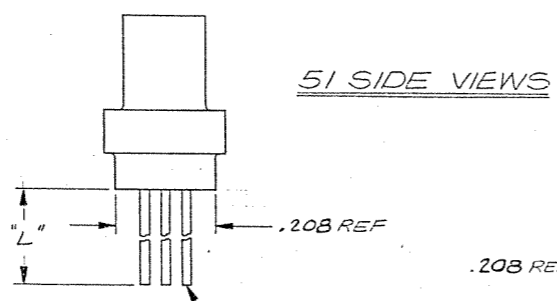
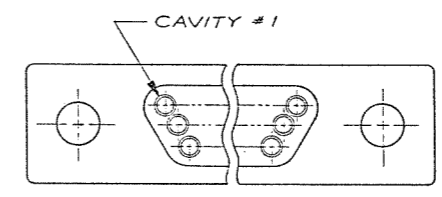
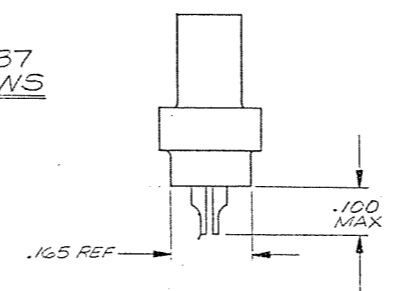
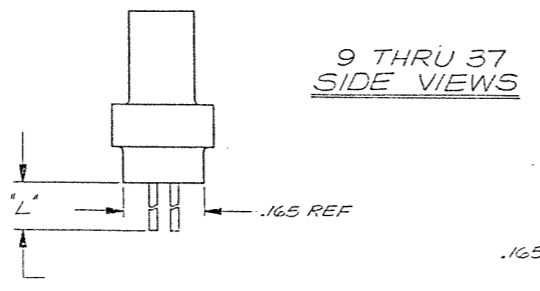
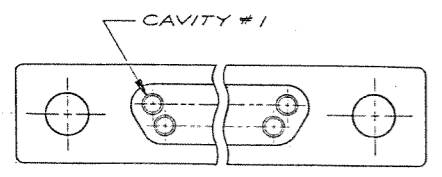
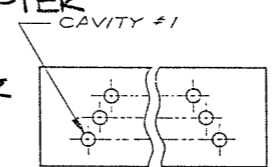

REAR VIEW OF PLUG CAVITY LAYOUT

3 SOLDER POT-ADAPTER (SHORT)
 3 USED ON 51 ONLY
 3 SOLDER POT-ADAPTER (LONG)

9 THRU 37 CONFIGURATION

(SHOW WITH WIRE TERMINATIONS FOR REFERENCE ONLY. SOLDER POT TERMINATIONS ARE THE SAME CONFIGURATION)

51 CONFIGURATION

(SHOW WITH SOLDER POT TERMINATIONS FOR REFERENCE ONLY. WIRE TERMINATIONS ARE THE SAME CONFIGURATION)

NOTES: UNLESS OTHERWISE SPECIFIED

1 MARK "MALCO" OR MALCO LOGO, MILITARY PART NO. (e.g. MB3513/06-*), CODE IDENT. NO., & DATE CODE WITH .047 MIN HIGH CHARACTERS IN APPROXIMATE LOCATION SHOWN.

2 EPOXY USING HYSOL #4215 & 3561.

3 SOLDER POT; MATL: BRASS PER QQ-B-626, COMP 360, 1/2 HARD
 FINISH: COPPER ALLOY/GOLD PLATED
 PIN CONTACT; MATL: COPPER ALLOY/GOLD PLATED
 HOUSING; MATL: (R3) POLYPHENYLENE SULFIDE RYTON 4-04 (BR-68) PER MIL-M-24519, COLOR BROWN

TE Connectivity Drawing 1-1532149-4

QTY	CODE	PART OR IDENTIFYING NO.	NOMENCLATURE OR DESCRIPTION
			UNLESS OTHERWISE SPECIFIED DIMENSIONS ARE IN INCHES TOLERANCES ARE: FRACTIONS DECIMALS ANGLES ± .XX ± ± .XXX ± ±
			CONTRACT NO. APPROVALS DATE DRAWN 1/4/23 CHECKER PR. ENG. 1-5-23 A.T.U.
			MATERIAL FINISH
			DO NOT SCALE DRAWING
			SCALE: NONE
			SHEET / OF /

PARTS LIST			
RACK & PANEL CONNECTOR, PLUG MCD PER MIL-C-83513			
SIZE	CODE IDENT. NO.	DRAWING NO.	PROD. CODE
D	98278	1-1532149-4	824
			CD

8 7 6 5 4 3 2 1

REVISIONS					
ZONE	LTR	ECN	DESCRIPTION	DATE	APPROVED
			SEE SHEET 1		

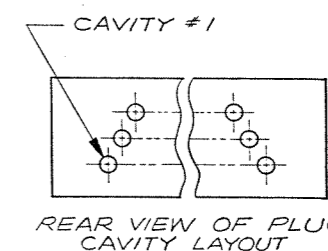
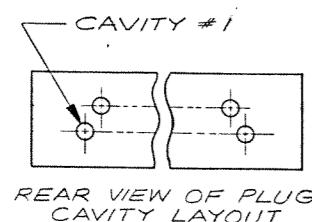
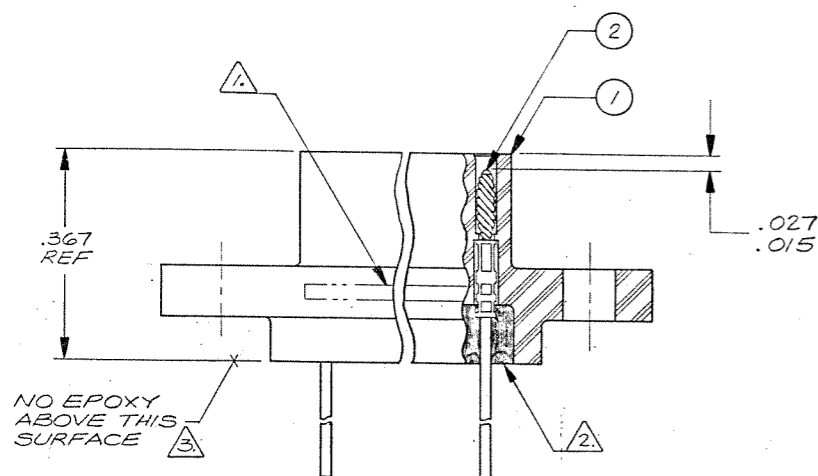
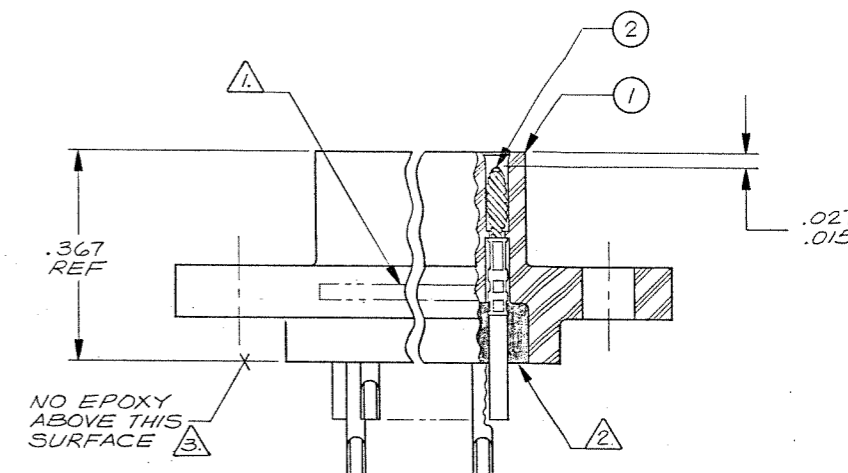
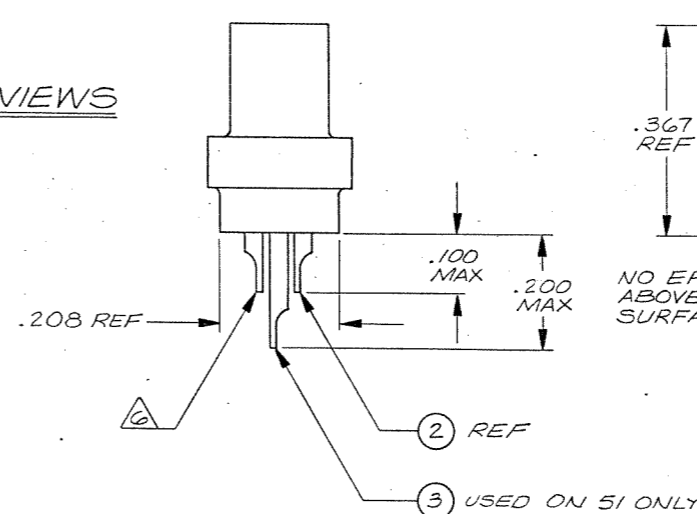
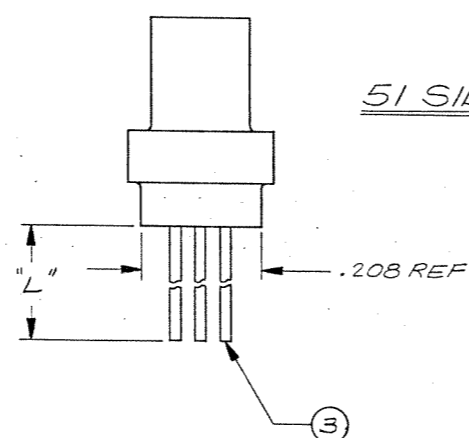
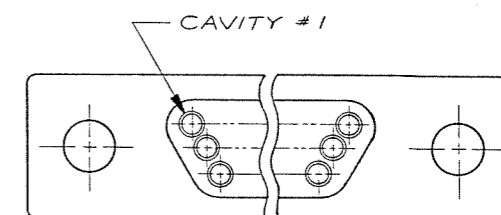
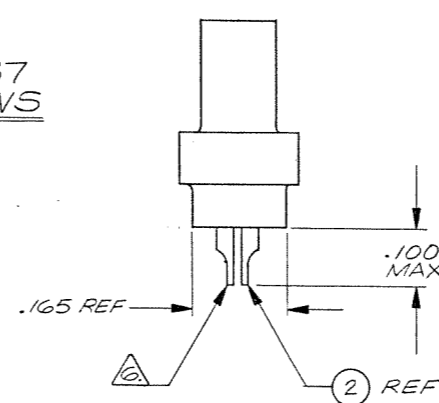
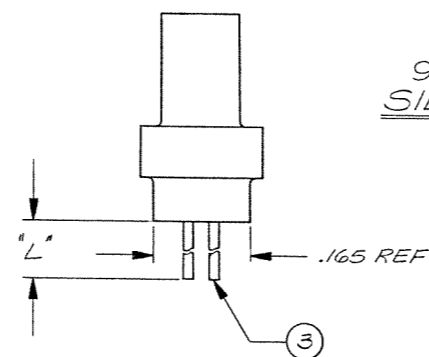
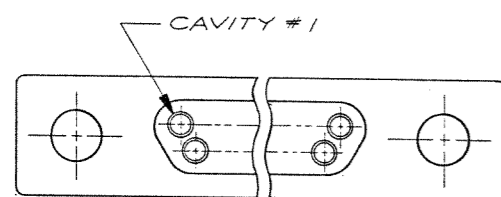

9 THRU 37 CONFIGURATION

(SHOW WITH WIRE TERMINATIONS FOR REFERENCE ONLY. SOLDER POT TERMINATIONS ARE THE SAME CONFIGURATION)

51 CONFIGURATION

(SHOWN WITH SOLDER POT TERMINATIONS FOR REFERENCE ONLY. WIRE TERMINATIONS ARE THE SAME CONFIGURATION)

NOTES: UNLESS OTHERWISE SPECIFIED

- 1. MARK "MALCO" OR MALCO LOGO, MILITARY PART NO. (e.g. M83513/06-*), CODE IDENT. NO., & DATE CODE WITH .047 MIN HIGH CHARACTERS IN APPROXIMATE LOCATION SHOWN.
- 2. EPOXY USING HYSOL # 4215 & 3561.
- 3. EPOXY WICKING - UNINSULATED WIRE — .050 MAX.
INSULATED WIRE UP TO # 25 AWG — .125 MAX.
INSULATED WIRE # 24 AWG OR LARGER — .200 MAX.
- 4. CRIMP LEADS OR SOLDER POTS INTO CONTACTS PER MEP 302-05.
- 5. NO SCRATCHES SHOWING BASE METAL PERMITTED ON SOLDER POTS.
- 6. CHAMFER ON SOLDER POTS ARE TO BE PARALLEL WITH SIDES OF CONNECTOR WITHIN 10 DEGREES.

TE Connectivity Drawing 1-1532149-4

QTY REQD	CODE IDENT	PART OR IDENTIFYING NO.	NOMENCLATURE OR DESCRIPTION	CONTRACT NO.	PROD. CODE
					824
PARTS LIST				TE Connectivity	
UNLESS OTHERWISE SPECIFIED DIMENSIONS ARE IN INCHES TOLERANCES ARE:				APPROVALS	
FRACTIONS DECIMALS ANGLES				DATE	
± .XX ± ±				DRAWN G SAUER 5-12-82	
± .XXX ± ±				CHECKED E Jhon 5-17-82	
MATERIAL				PR. ENG. [Signature]	
FINISH				APPD. [Signature]	
DO NOT SCALE DRAWING				SIZE CODE IDENT NO. DRAWING NO.	
				D 98278 1-1532149-4	
				SCALE NONE SHEET / OF /	
				REV. B1	