



P1200

SPECIFICATIONS

- ◆ **Rugged Design for Harsh Environments**
- ◆ **High Burst Pressure Limit**
- ◆ **High Reliability**
- ◆ **Low and High Level Output Signals**

The P1200 Series pressure transducers and transmitters provide high accuracy pressure measurement of liquids and gases. These robust transducers combine hybrid electronics with highly reliable strain gauge sensing technology to offer superior performance in rugged applications. Constructed from media compatible 17-4 PH stainless steel, the P1200 provides exceptional performance in extreme environments.

Accuracy of the P1200 is guaranteed to be within $\pm 0.20\%$ F.R.O. over a wide temperature compensated range of -20°C to 80°C . The P1200 is available with either cable or connector terminations or offers a variety of outputs including 0-20 mV, 0-100 mV, 0-5 V and 4-20 mA. Six selectable pressure ports are available to suit most application requirements. Pressure ranges include 0-75 psi to 10,000 psi (0-5 bar to 700 bar) and can be referenced in absolute, sealed or vented gauge. The P1200 Series maintains a high burst rate of greater than 20x the rated pressure and 5x overpressure limit without damage to the sensor due to a positive over travel stop.

For parts requiring RoHS compliance, please contact factory.

FEATURES

- ◆ Typical Accuracy of $\pm 0.15\%$ F.R.O.
- ◆ Cable/Connector Termination
- ◆ Stainless Steel Media Isolated
- ◆ 5x Overpressure Protection
- ◆ High and Low Level Output

APPLICATIONS

- ◆ Vehicle Brake System Monitoring
- ◆ Gas Production
- ◆ Farm Machinery
- ◆ Hydraulic Control Monitoring

PERFORMANCE SPECS

Series	P1200	P1230	P1240	P1260	P1280
Model Number	P1221/3	P1231/3	P1241/3	P1261/3	P1281/3
Input Voltage	10VDC (12 V max)	10VDC (12 V max)	10VDC (12 V max)	18-32VDC	10-36VDC
Impedance (ohms)	1000 to 1600	-	-	-	-
Current (mA max)	10	12	12	25	-
Full Range Output ($\pm 2\%$)	20mV	100mV	5VDC	5VDC	4-20 mA (16 mA $\pm 2\%$)
Impedance (ohm)	1000 ± 50	<10	<10	<10	Load Resistance 1300 ohm (max) at 36VDC
Current (mA max)	-	-	5	5	-
Frequency Response	2.5 to 40 kHz	2 kHz	2 kHz	1 kHz	1 kHz
Residual Unbalance	< ± 2	< ± 2	< ± 2	< ± 2	4.0 mA +2-0
Weight oz (gm)	3.4 (95)	4.4 (125)	4.4 (125)	4.4 (125)	4.4 (125)

COMMON SPECIFICATIONS

Pressure Ranges

High (psi) 0-75, 100, 150, 220, 250, 350, 500, 750, 1000, 1500, 2200, 2900, 3500, 5000, 7500, 10,000

(bar) 0-5, 7, 10, 15, 20, 25, 35, 50, 70, 100, 150, 200, 250, 350, 500, 700

DIN (bar) 6, 10, 16, 25, 40, 60, 100, 160, 250, 400, 600

Pressure References Vented gauge (Sensors should only breathe dry noncorrosive gases. Sealed gauge and absolute to special order).

Pressure Limit >5x full range pressure or 12,000 psi (830 bar), whichever is less.

Burst Pressure >20 x full range pressure or 22,000 psi (1,520 bar), whichever is less

Pressure Media Liquids or gases compatible with 17-4 PH stainless steel

Combined Non-linearity, Hysteresis

and Non-repeatability <±0.15% F.R.O. (typ); ±0.20% F.R.O. max (BSL) – high range

Temperature Range

Operable -65°F to 185°F (-54°C to 85°C) [P1221/4 -65°F to 250°F (-54°C to 120°C)]

Compensated -4°F to 185°F (-20°C to 85°C) [P1221/4 -4°F to 212°F (-20°C to 100°C)]

Storage -65°F to 250°F (-54°C to 120°C)

Combined Thermal Zero

And Sensitivity Shift <±0.010% F.R.O./°F (±0.02% F.R.O./°C) over compensated temperature range

Total Thermal Error Band*

(including NLH) %F.R.O.

-4° to 185°F (-20° to 85 °C ±1.2% typical, ±2.0% max. (over compensated temperature range)

Shock Resistance

1000 g for 5 msec

Vibration Resistance

Surpasses MIL STD810C Method 514-2 Curve L and EUROCAE ED 14A/RTCA 160A

Humidity

Connector Version 95% Relative humidity

Cable Version Immersible to IP67

EMC

Emissions to EN55022 (CISPR 22) Limit B; Radiated Immunity to IEC 801-3 Level 3 10 V/m; Burst Transients to IEC 801-4 Level 3 (2kV); Electrostatic Discharge to IEC 801-2 Level 2 (4kV contact); Surges to IEC 801-5 class 3 (2kV).

Insulation Resistance

500 MOhm at 50 VDC

DIMENSIONS

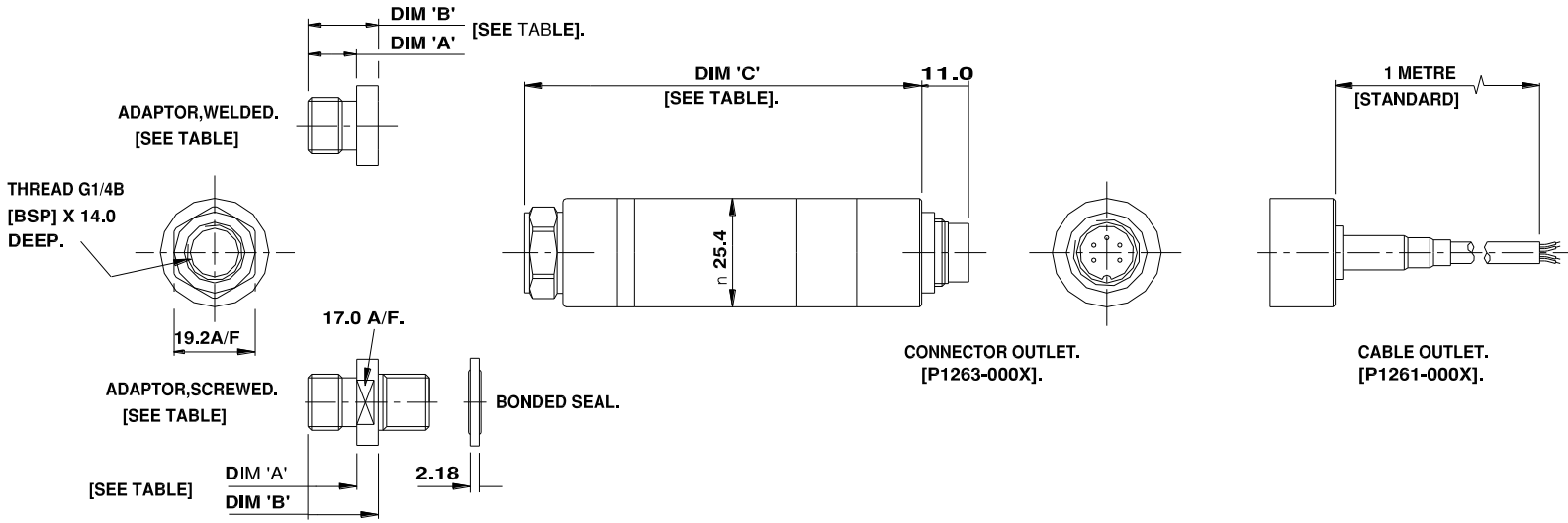

Male Connector Part Number: Amphenol T3262 000

Mating Female Connector: Amphenol T3361 004

Adapters					
Thread Size	Code Welded	A	B	Code Screw In	B
G1/4A (BSP) (F)	0001				
G1/4A (BSP) (M)	0002	0.46 (11.7)	0.67 (16.9)	0022	0.70 (17.8)
M14 x 1.5 (M)	0003	0.40 (10.2)	0.61 (15.4)	0023	0.62 (15.8)
7/16"-20UNF-2A (M)	0004	0.56 (14.3)	0.77 (19.5)	0024	0.78 (19.8)
1/4"-18NPT (M)	0005	0.67 (17.0)	0.87 (22.2)	0025	0.92 (23.4)
M10 x 1.0 (F)	0006		0.60 (15.2)	0026	0.61 (15.4)
1/4"-18NPT (F)	0009				

	Dimension C	
	0 to 5 - 50 bar	0 to 70 - 700 bar
P1221/3-00XX	65.0	66.5
P1231/3-00XX	79.0	80.5
P1241/3-00XX	79.0	80.5
P1261/3-00XX	93.4	95.0
P1281/3-00XX	79.0	80.5

CONNECTIONS

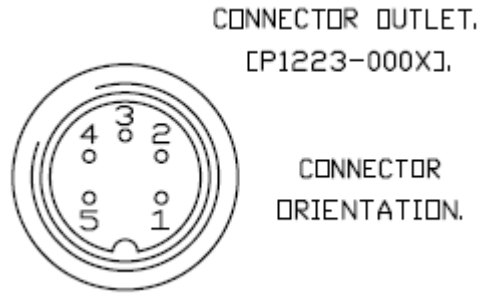
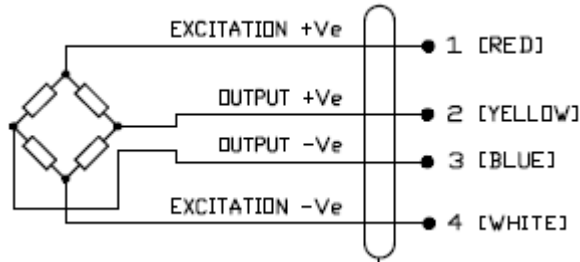

ORDERING INFORMATION

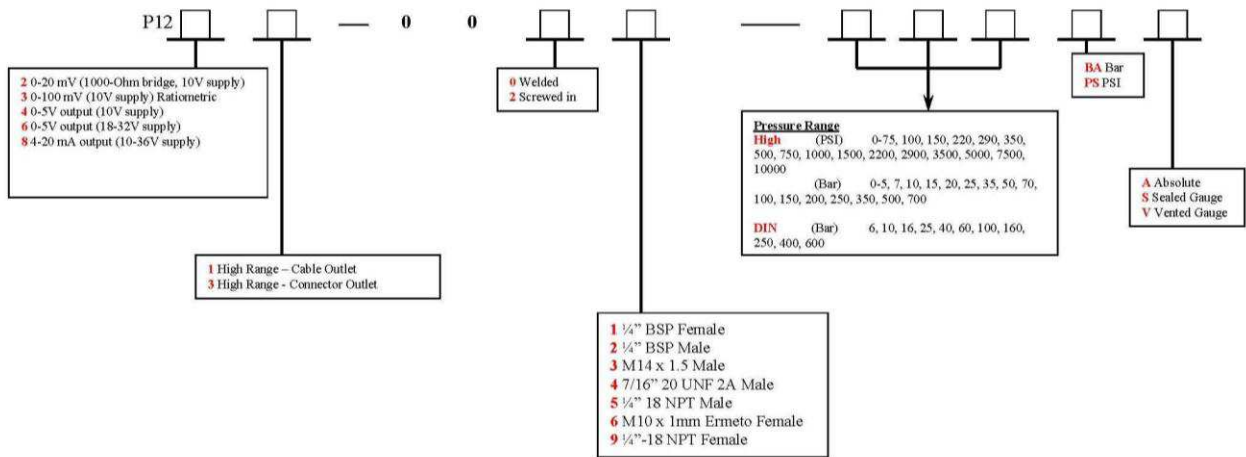

NOTE: Unit comes standard with 1 meter of cable.

For a different cable length, add 2 digits "xx" to the end of the configuration above indicating the length desired. Max 20 meters.

NORTH AMERICA

Measurement Specialties, Inc.,
a TE Connectivity Company
Phone: 800-522-6752
Email: customercare.frm@te.com

EUROPE

Measurement Specialties (Europe), Ltd.,
a TE Connectivity Company
Phone: 800-440-5100
Email: customercare.lcsb@te.com

ASIA

Measurement Specialties (China), Ltd.,
a TE Connectivity Company
Phone: 0400-820-6015
Email: customercare.shzn@te.com

TE.com/sensorsolutions

Measurement Specialties, Inc., a TE Connectivity company.

Measurement Specialties, TE Connectivity, TE Connectivity (logo) and EVERY CONNECTION COUNTS are trademarks. All other logos, products and/or company names referred to herein might be trademarks of their respective owners.

The information given herein, including drawings, illustrations and schematics which are intended for illustration purposes only, is believed to be reliable. However, TE Connectivity makes no warranties as to its accuracy or completeness and disclaims any liability in connection with its use. TE Connectivity's obligations shall only be as set forth in TE Connectivity's Standard Terms and Conditions of Sale for this product and in no case will TE Connectivity be liable for any incidental, indirect or consequential damages arising out of the sale, resale, use or misuse of the product. Users of TE Connectivity products should make their own evaluation to determine the suitability of each such product for the specific application.

© 2015 TE Connectivity Ltd. family of companies All Rights Reserved.