

REVISIONS ÄNDERUNGEN					
P	LTR	DESCRIPTION BESCHREIBUNG	DATE	DWN	APVD
C1		EXTENSION OF PART OF 0.5 mm	01APR98	SCHZ	RK
C2		WIDTH 11.95 WAS 12.0	25JUN98	CS	RK
D1		DIM 9.3 WAS 9.0 (C4)	25SEP98	CS	RK
D2		969406-2 PART OBSOLETE	26MAY2021	GMN	KV

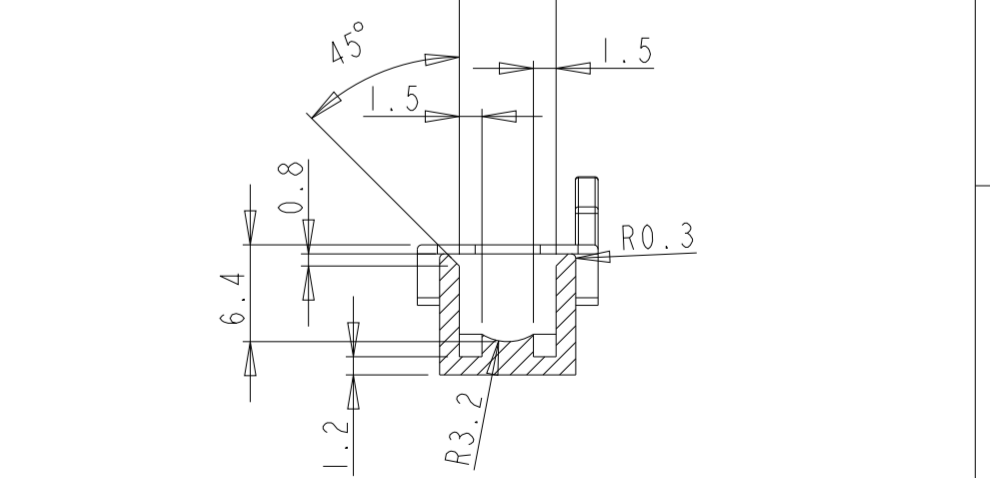
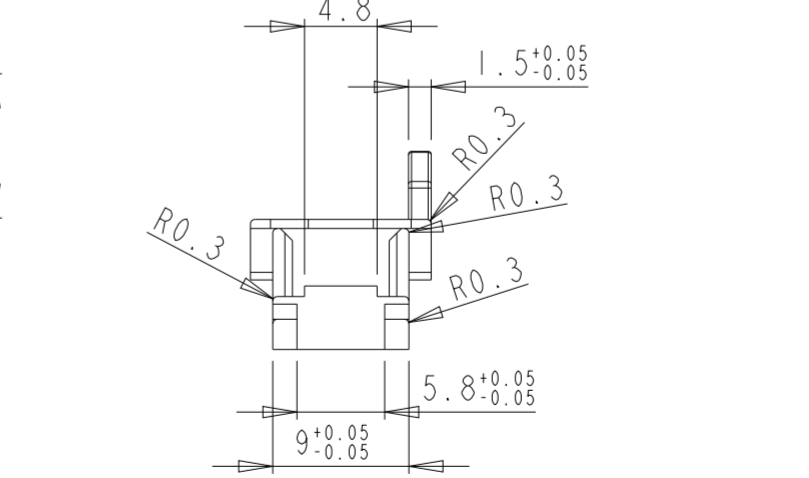
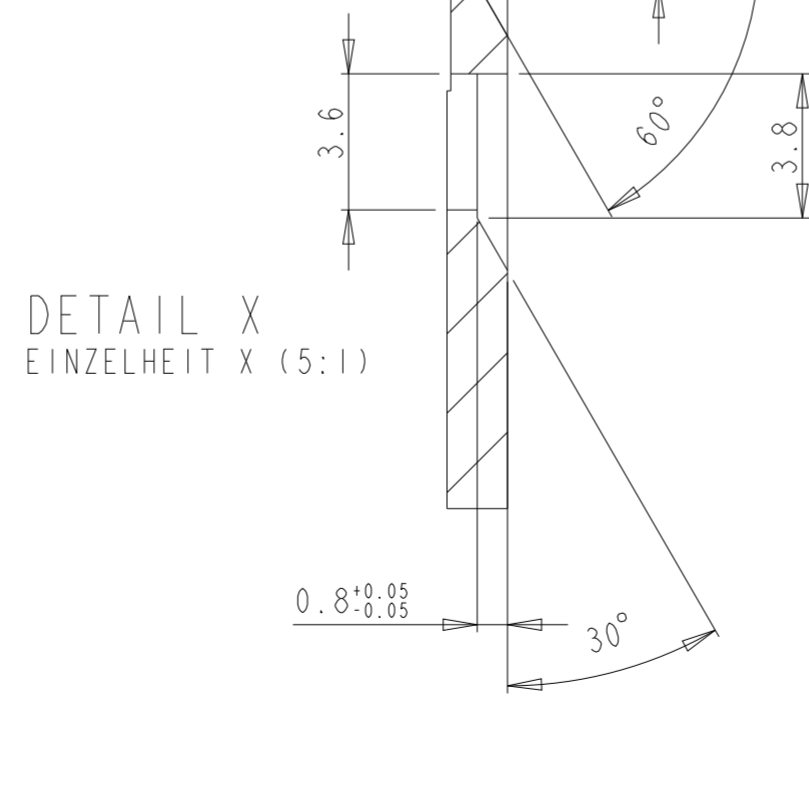
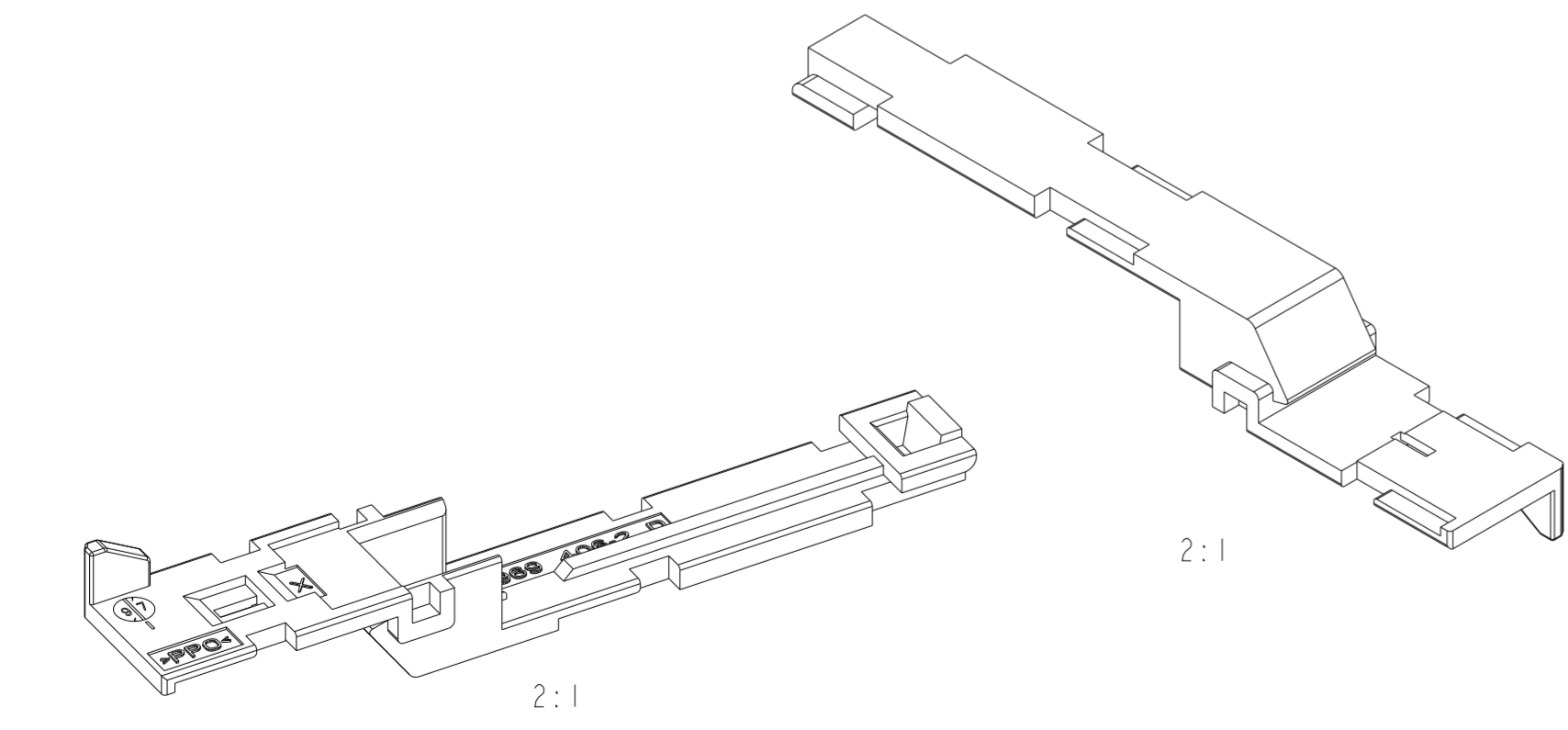
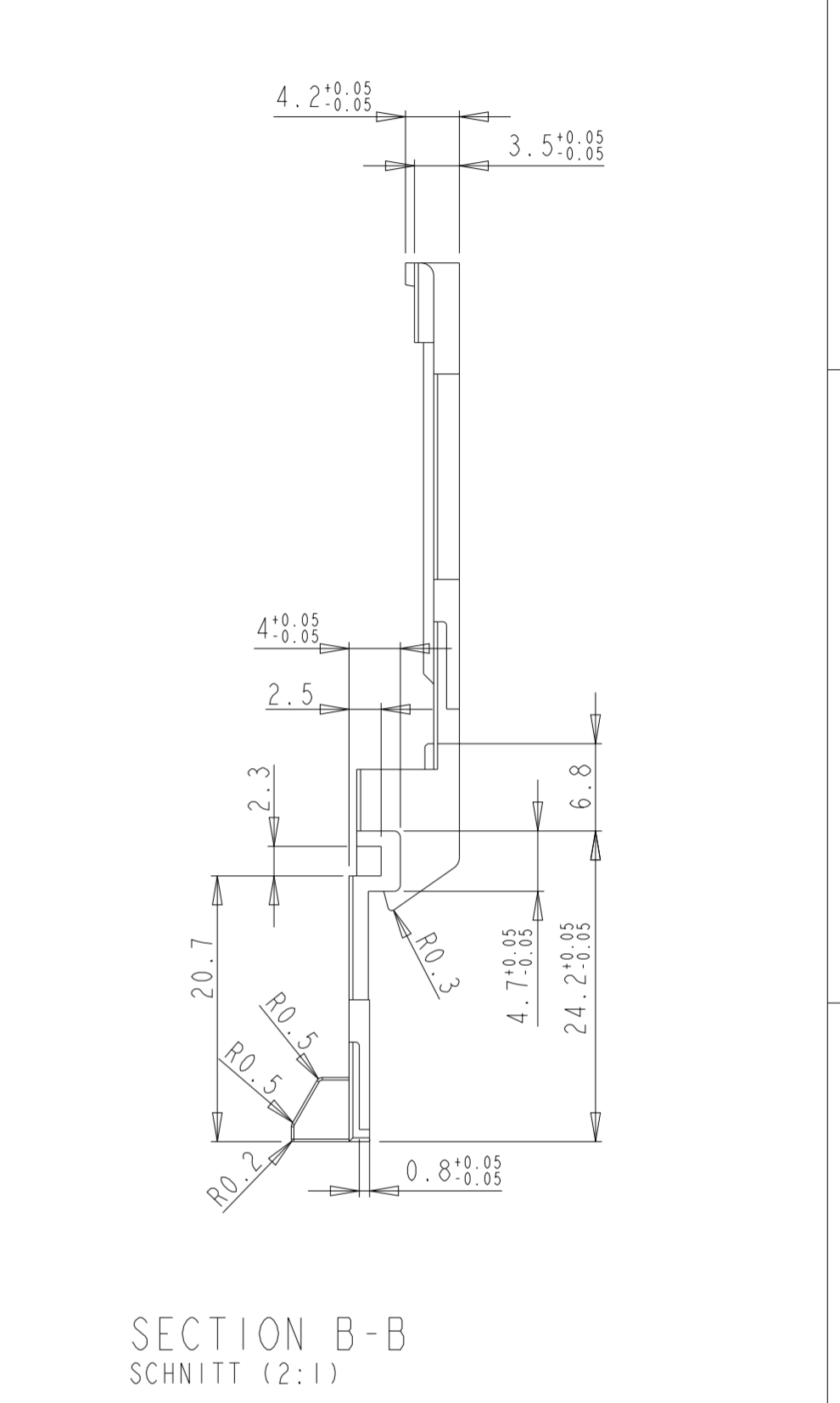
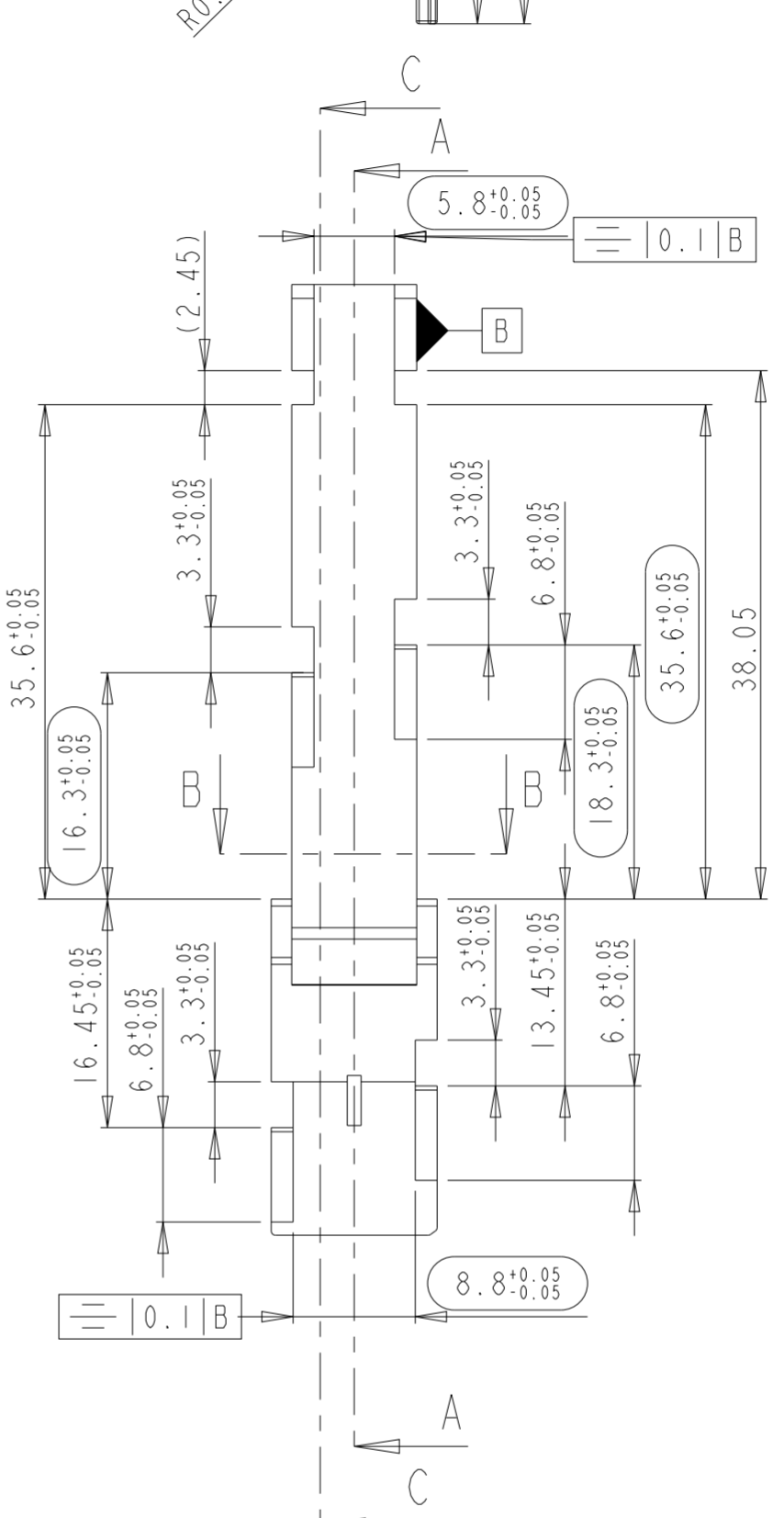
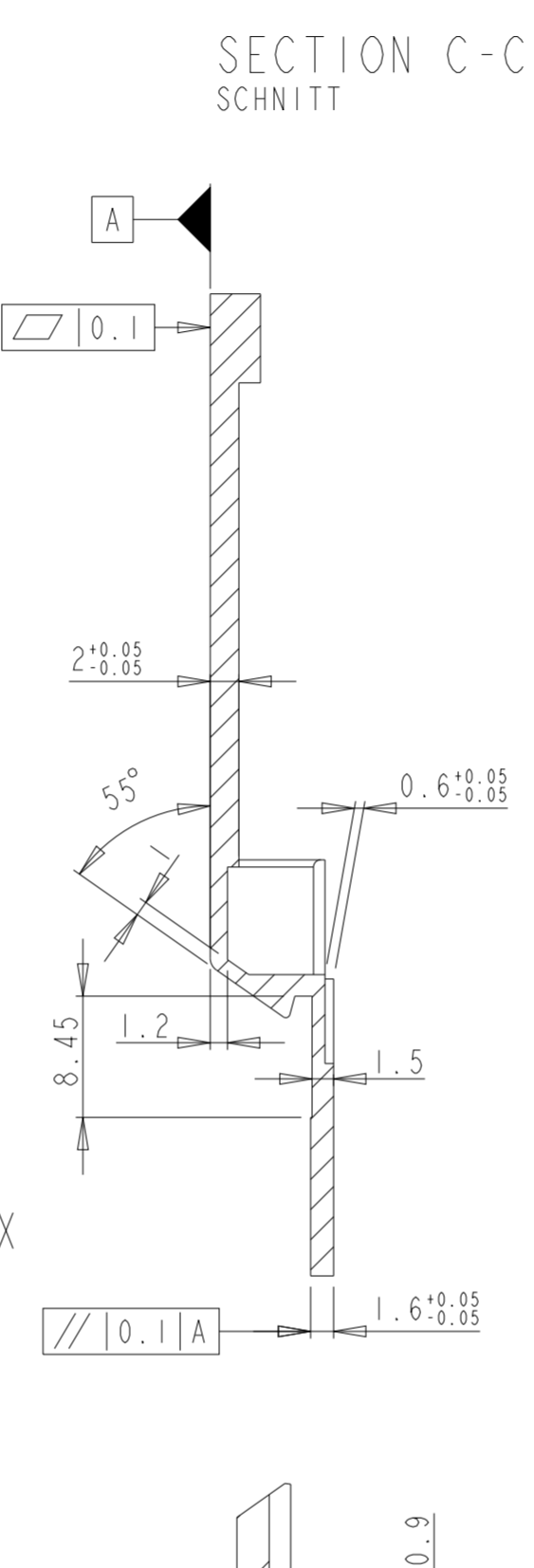
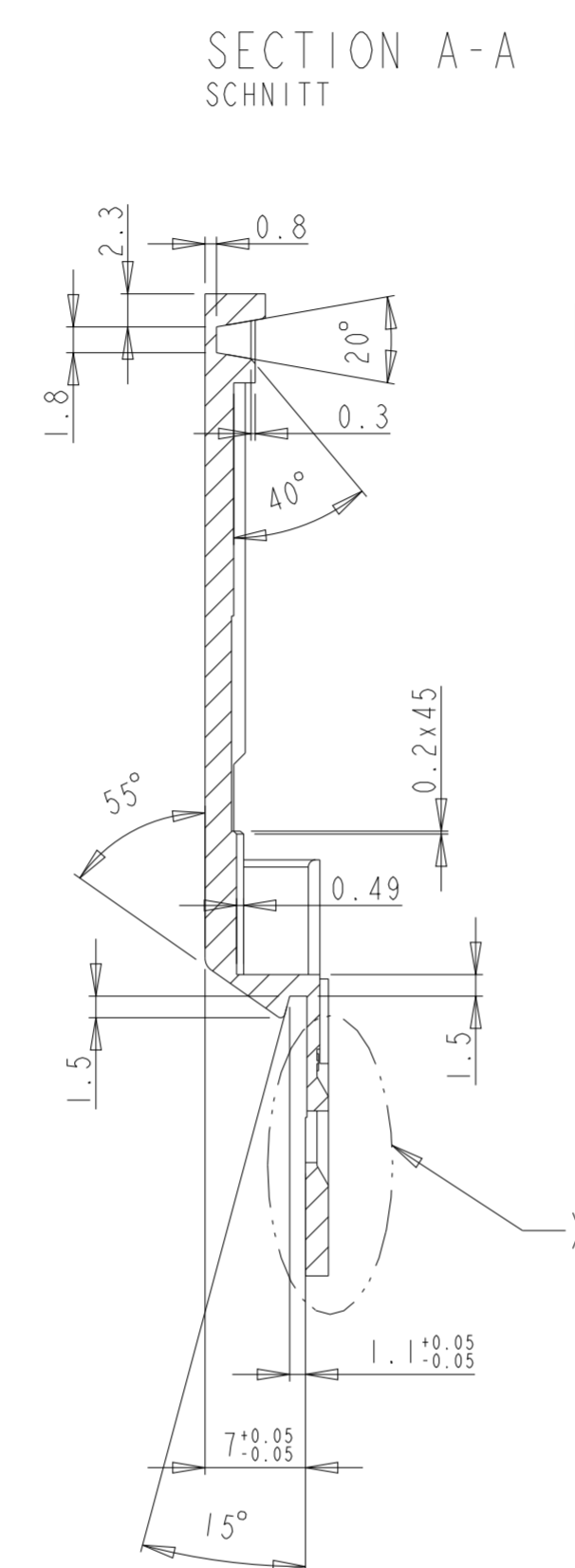
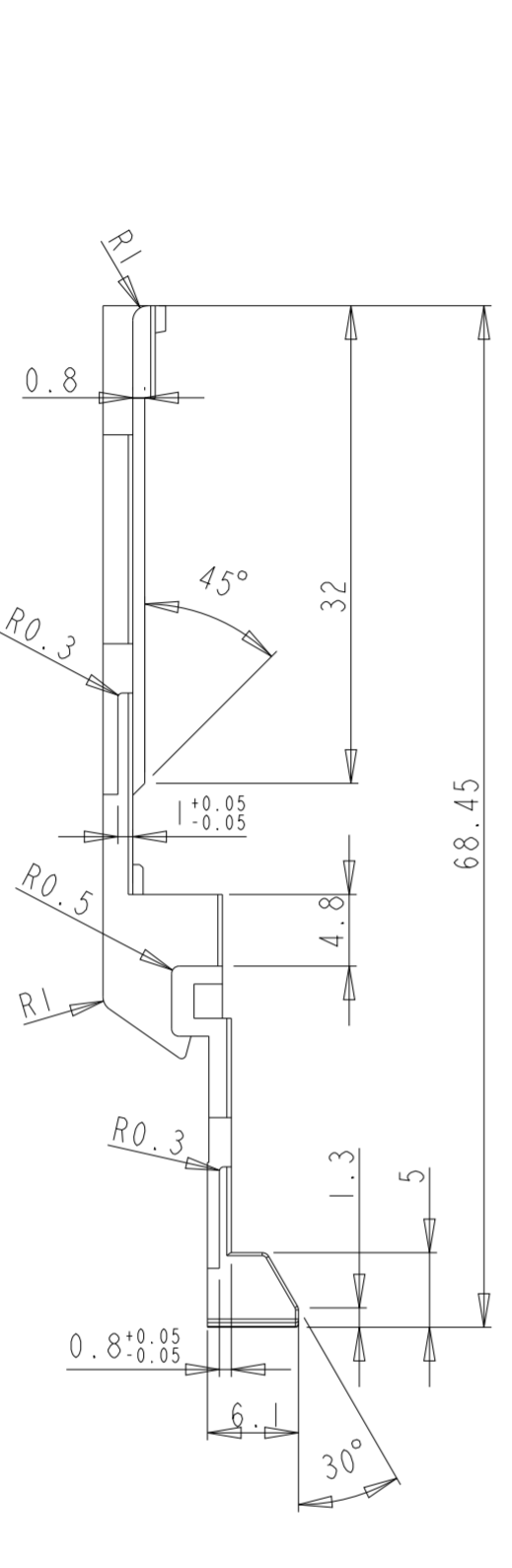
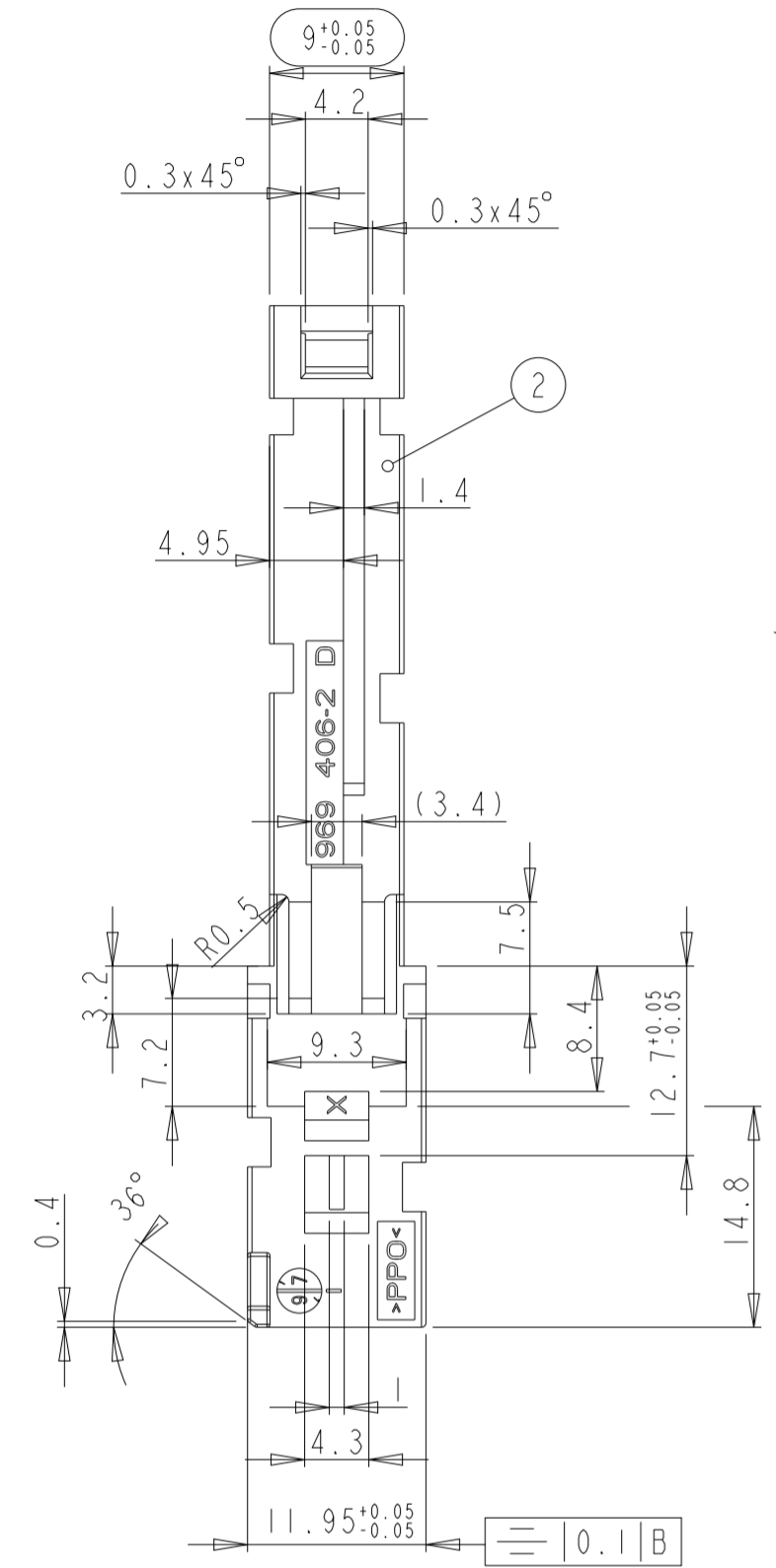

THIS DRAWING IS A CONTROLLED DOCUMENT. DIESES ZEICHNUNGSDOKUMENT WIRD DURCH AMP INCORPORATED KONTROLLIERT. ÄNDERUNGEN, DIE DEM TECHNISCHEN FORTSCHRITT DIENEN, SIND VORBEHALTEN. DEN JEWELIG LETZTGESETZTEN ÄNDERUNGSSTAND ERFAHREN SIE AUF ANFRAGE.		DWN C.Schrettlinger 05NOV97	TE Connectivity	
DIMENSIONS: MASSEINHEITEN: MM		CHK R.Kraemer 05NOV97	NAME SLIDE SCHIEBER	RESTRICTED TO NUR FUER
TOLERANCES UNLESS OTHERWISE SPECIFIED: ALLGEMEINTOLERANZEN		APVD G.Feldmeier 05NOV97	SIZE A2	REVISIONS REV D2
0 PLC ±0.1 1 PLC ±0.1 2 PLC ±0.1 3 PLC ± 4 PLC ± ANGLES/WINKEL ±1		PRODUCT SPEC PRODUKTSPEZ. -	CAGE CODE 00779	DRAWING NO ZEICHNUNGS-NR. G-969406
MATERIAL -		APPLICATION SPEC VERARBEITUNGSSPEZ. -	WEIGHT GEWICHT -	SCALE MASSSTAB 2:1
material_2		FINISH/OBERFLAECHE/FARBE -	CUSTOMER DRAWING /KUNDENZEICHNUNG	SHEET BLATT 1 OF VON 2

PROJEKT NR.:
E97-52520

REVISIONS		DATE	DWN	APVD
ÄNDERUNGEN				
P	LTR	DESCRIPTION		
		BESCHREIBUNG		
-	-	SEE SHEET 1	-	-

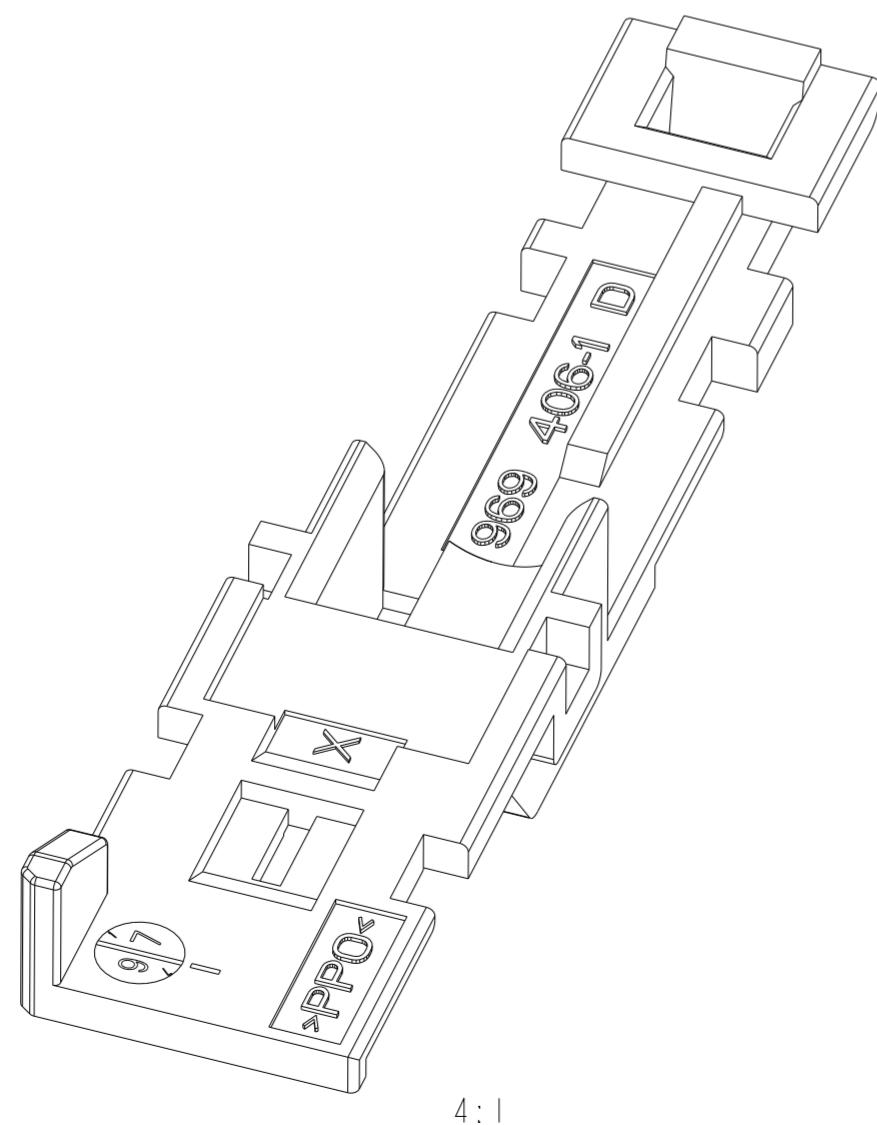
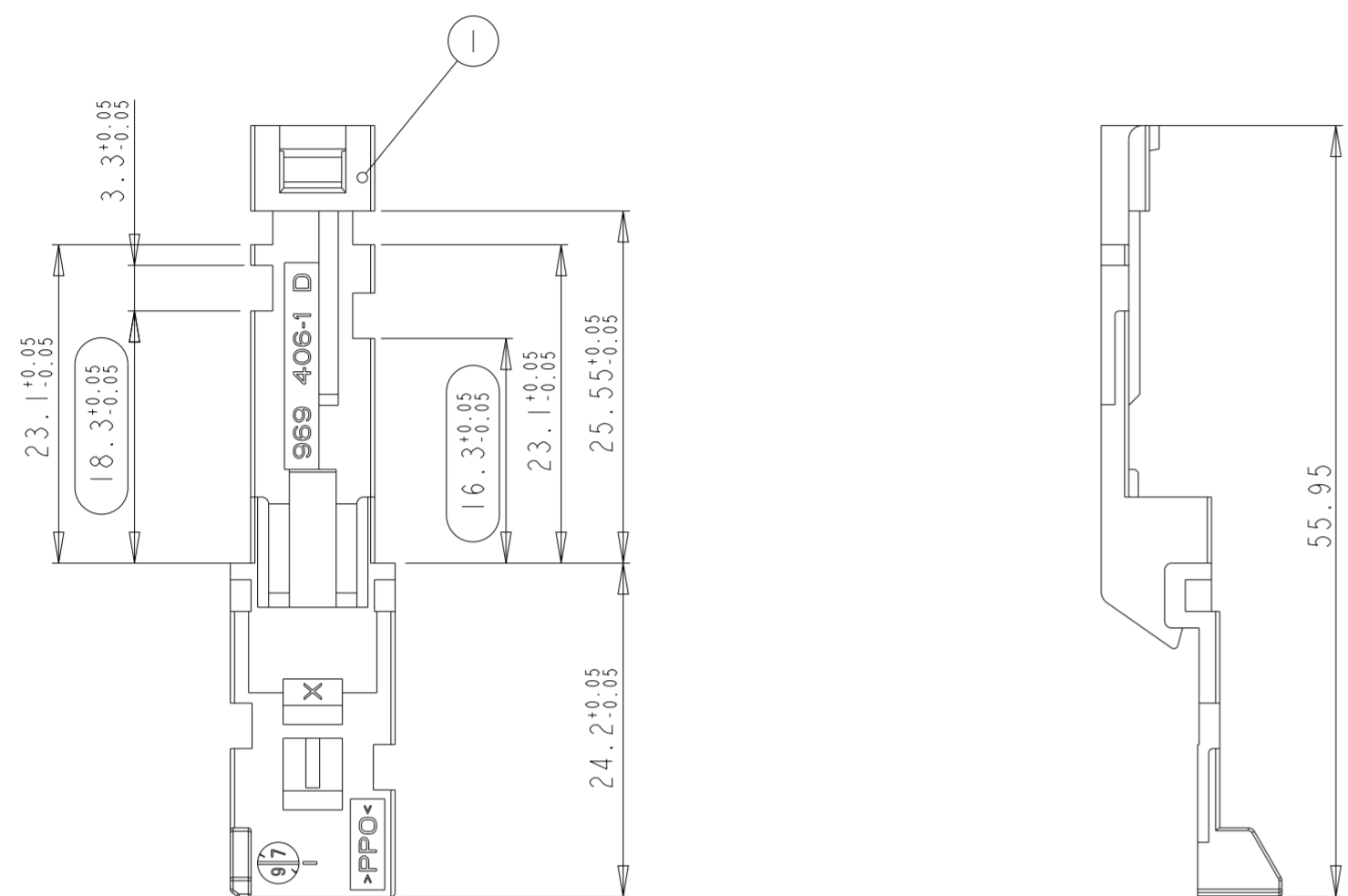

4:1

PACKING NOTE:

1000 PARTS PACKED INTO CARDBOARD BOX

VERPACKUNGSHINWEIS:

1000 TEILE IN KARTON VERPACKT

OBSELETE	969 406-2	2		SLIDE LONG SCHIEBER LANG	ANTHRACITE ANTHRAZIT	NORYL SEI GFNI
7832108-01	969 406-1	1	-	SLIDE SHORT SCHIEBER KURZ	ANTHRACITE ANTHRAZIT	NORYL SEI GFNI
SIEMENS ORDER NO. BESTELL-NR.	AMP ORDER NO. BESTELL-NR.	POS.	QTY. STK.	DESCRIPTION BENENNUNG	SURFACE OBERFLAECHE COLOUR/FARBE	MATERIAL
THIS DRAWING IS A CONTROLLED DOCUMENT. DIESES ZEICHNUNGSDOKUMENT WIRD DURCH AMP INCORPORATED KONTROLLIERT. ÄNDERUNGEN, DIE DEM TECHNISCHEN FORTSCHRITT DIENEN, SIND VORBEHALTEN. DEN JEWELIGS LETZTGESETZTEN ÄNDERUNGSSTAND ERFAHREN SIE AUF ANFRAGE.				DWN C. Schrettlinger 05NOV97	TE Connectivity	
DIMENSIONS: MASSEINHEITEN: [mm]	TOLERANCES UNLESS OTHERWISE SPECIFIED: ALLGEMEINTOLERANZEN		CHK R. Kraemer 05NOV97	APVD G. Feldmeier 05NOV97	NAME SLIDE SCHIEBER	
0 PLC ±0.1 1 PLC ±0.1 2 PLC ±0.1 3 PLC ± 4 PLC ±	ANGLES/WINKEL ±1 FINISH/OBERFLAECHE/FARBE		PRODUCT SPEC PRODUKTSPEZ. -	APPLICATION SPEC VERARBEITUNGSSPEZ. -	SIZE A2	CAGE CODE 00779
MATERIAL -	finish_spec_2	WEIGHT GEWICHT -	CUSTOMER DRAWING	/KUNDENZEICHNUNG	DRAWING NO. ZEICHNUNGS-NR. C-969406	RESTRICTED TO NUR FUER -
SCALE MASSSTAB 2:1		SHEET BLATT 2 OF 2		REV D2		