

SUGGESTED MATING TAB

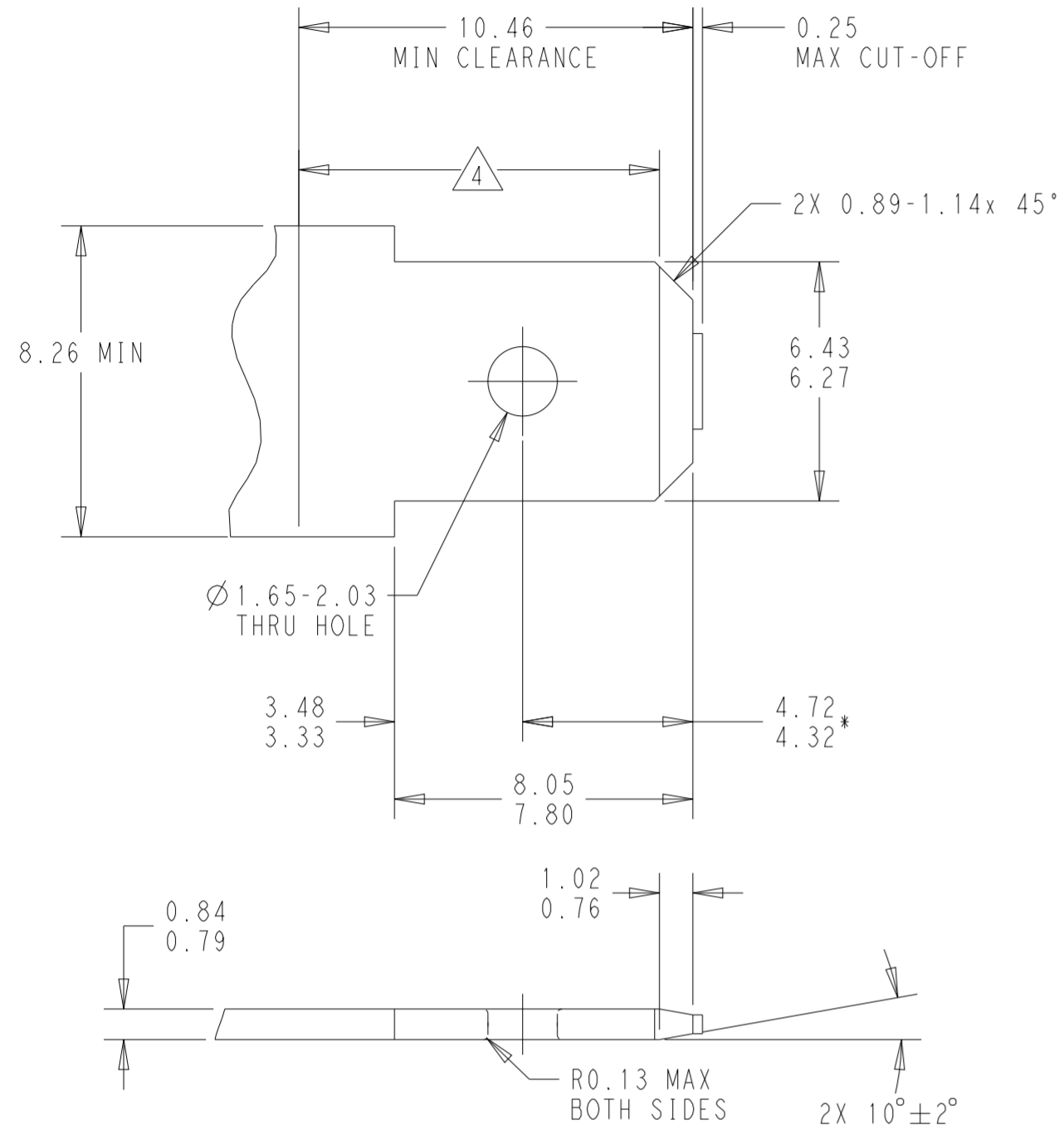

1. MATERIAL: 1/2 HARD BRASS OR NICKEL PLATED STEEL
 2. NO BURRS PERMISSIBLE AROUND HOLE
 3. TIN PLATING IS REQUIRED ON BRASS WHEN TERMINAL TEMP. IS OVER 225°F
 4. MUST BE FLAT WITHIN 0.08 OVER THIS LENGTH
 5. HOLE MUST BE SYMMETRICAL ABOUT TAB \perp WITHIN 0.08.
- * TO BE USED ONLY WHEN SHOULDER IS ELIMINATED.

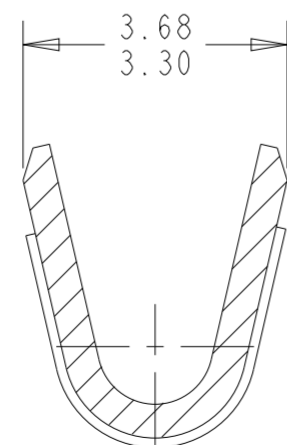

SECTION N-N
SCALE 10:1

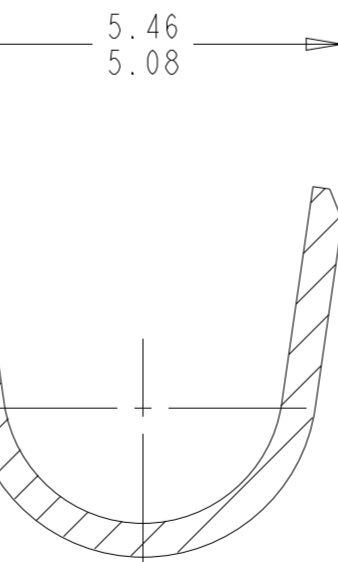
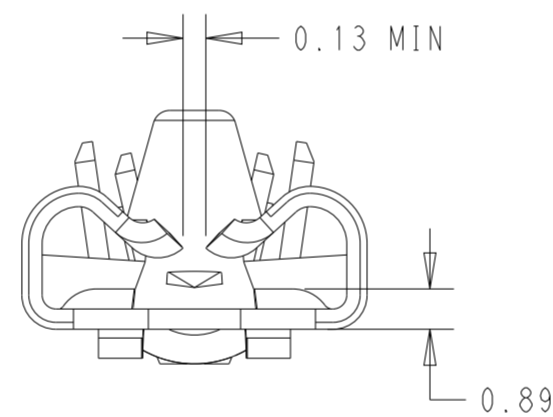

SECTION P-P
SCALE 10:1

REVISIONS

P	LTR	DESCRIPTION	DATE	DWN	APVD
B		REDRAWN/REVISED PER ECN-24-245855	27DEC2023	BKW	DH

1. PRODUCT PROVIDED IN CONTINUOUS STRIP FORM, BREAKS MAY BE PRESENT
2. THIS DIMENSION MUST BE MAINTAINED FOR PROPER FUNCTION OF THE LATCHING MECHANISM.
3. WIRE RANGE:
16-14 AWG / 2.29-3.94 INSULATION DIAMETER

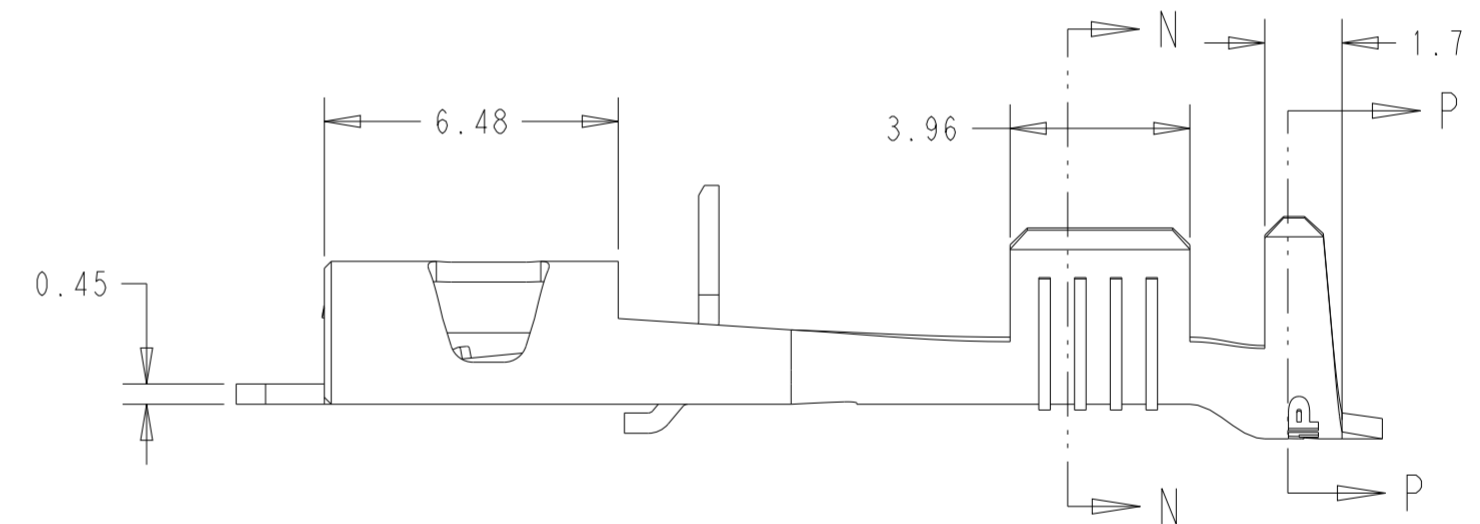
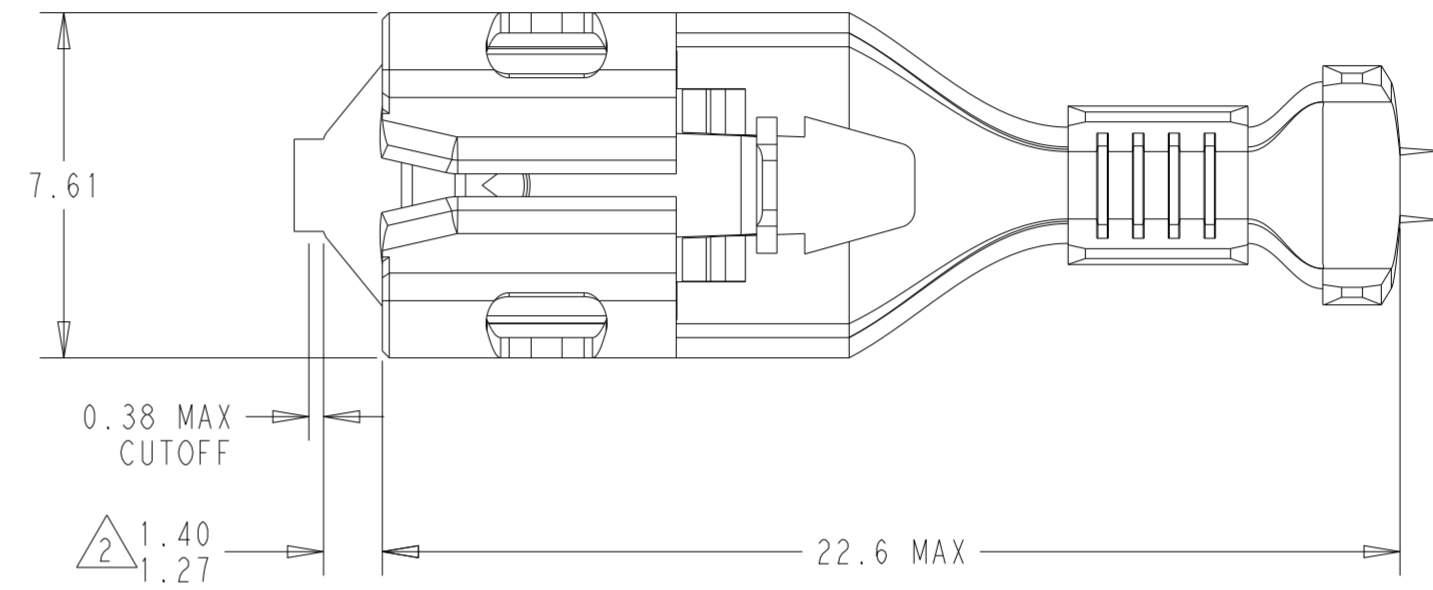

NICKEL PLATED	STEEL	2238104-1
FINISH	MATERIAL	PART NUMBER

THIS DRAWING IS A CONTROLLED DOCUMENT.		DWN B. WEAVER 27DEC2023	TE Connectivity	
DIMENSIONS: mm		CHK D. HUMPHREY 27DEC2023		
TOLERANCES UNLESS OTHERWISE SPECIFIED:		APVD W. MOYER 27DEC2023	NAME RECEPTACLE, POSITIVE-LOCK 250 SERIES	
0 PLC ±	1 PLC ±	PRODUCT SPEC 108-143022	SIZE A2	
2 PLC ±0.25	3 PLC ±	APPLICATION SPEC 114-2074	CAGE CODE 00779	DRAWING NO C-2238104
4 PLC ±	ANGLES ±	WEIGHT -	RESTRICTED TO -	SCALE 6:1
MATERIAL SEE TABLE	FINISH SEE TABLE	CUSTOMER DRAWING	SHEET 1 OF 1	REV B