

CHAMP Z-Dok Connector System

Product Facts

- The CHAMP Z-Dok Connector System is the latest addition to the Docking CHAMP connector family
- Operating bandwidth up to 6.25 Gb/s
- Familiar, robust, 4 row, design
- Blindmate design
- Utilizes TRI-Q Differential Pair, Contact System
- Each differential pair in close proximity to a dedicated ground, providing uniform impedance profile and low noise in a 100Ω system.
- Ground contacts are confined to rows B & E to simplify trace routing, control crosstalk, and to minimize impedance discontinuities at the board interface
- Size -In increments of 8 differential pairs (8-64 pairs)
- Sequenced mating (ESD, Gnd-Signal or Gnd-Signal Sensing)
- Housings are made of high temperature LCP
- UL and CSA approvals pending
- Boardlocks :
 - Provide stability during wave soldering
 - ESD Style-Mate first break last
 - Sensing Style-Mate last break first

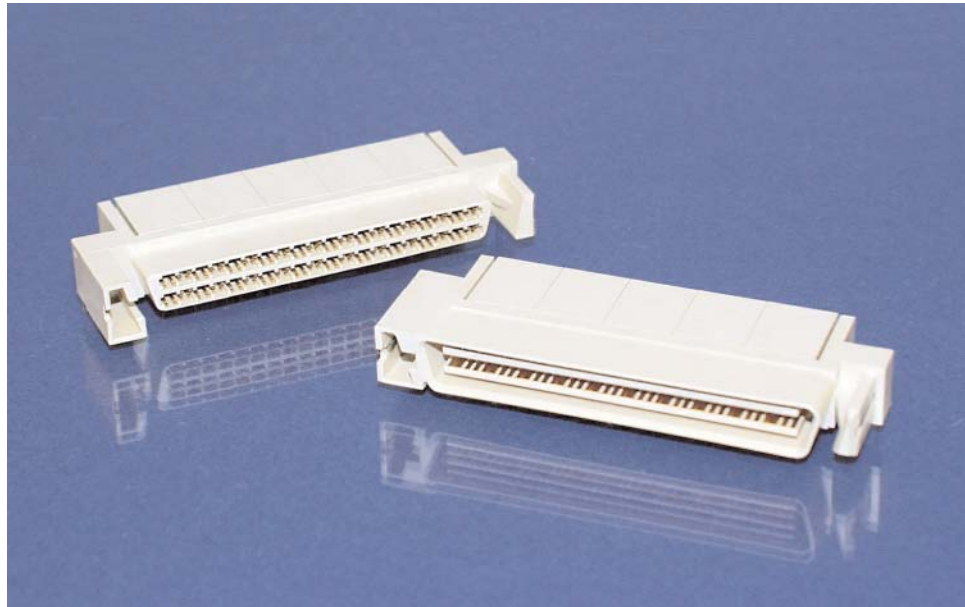

The CHAMP Z-Dok Connector System plug and receptacles

The CHAMP Z-Dok Connector System is designed for docking applications at data rates up to 6.25 Gbps using standard board materials and routing techniques. The CHAMP Z-Dok Connector system utilizes a familiar robust blindmate design derived from the very popular CHAMP .050 Series connector family. The CHAMP Z-Dok Connector System also utilizes the revolutionary TRI-Q Differential

Pair Contact System to maximize data throughput while minimizing pair to pair crosstalk and impedance discontinuities through the connector and its footprint. This connector is available in size increments of 8 differential pairs (8-64 pairs), with 40 to 64 pair products as standard offerings. The robust blindmate guides also incorporate a unique contact design that can be supplied in two versions; an

ESD version to insure dissipation of ESD in a mate first break last mating sequence or a sensing contact version which mates last and breaks first. This sense circuit can be utilized to insure full seating of the card before initialization of circuits. The CHAMP Z-Dok Connector System offers sequenced mating of ground and signal circuits to insure proper initialization of the mating cards.

- Fully validated SPICE models: E-mail requests to modeling@tycoelectronics.com
- Samples: E-mail requests to zdok@tycoelectronics.com
- Pro/E models and IGES models: E-mail requests to ampmodels@tycoelectronics.com
 - Application Specification 114-13068
 - Product Specification Design Objectives 108-1985

www.tycoelectronics.com
www.Z-Dok.com

Z-Dok Connector Assembly Plug (Continued)

Part Number: 1367198-X
1367444-X

Material and Finish

Housing — Polyester, Natural

Contacts — Copper Alloy

Boardlocks — Brass

Plating

Boardlocks — 2.0 µm Tin-Lead over 1.00 µm Nickel

Contacts — 0.76 µm MIN Gold in contact area, 2.5 µm Tin-Lead in termination area, over 1.27 µm MIN Nickel

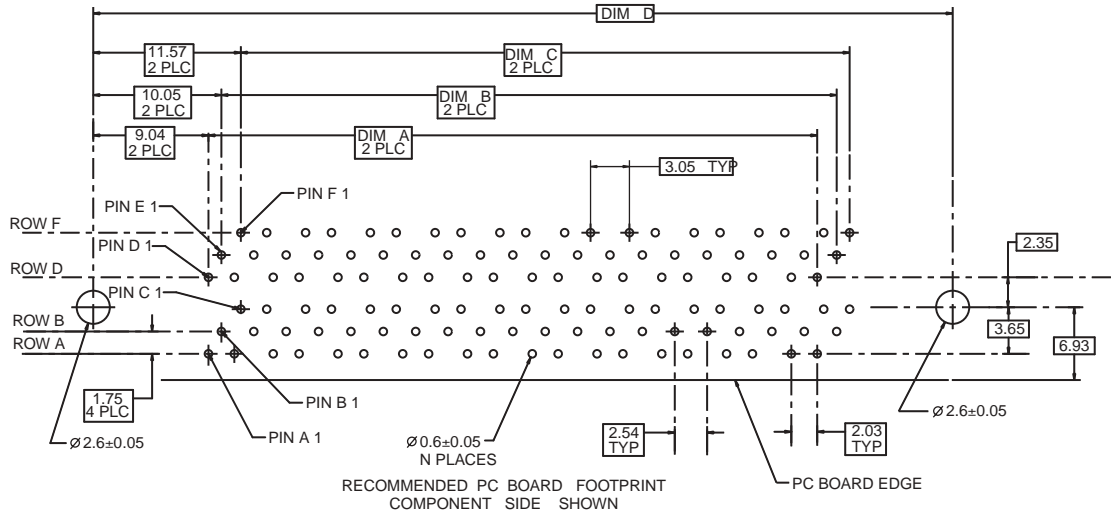
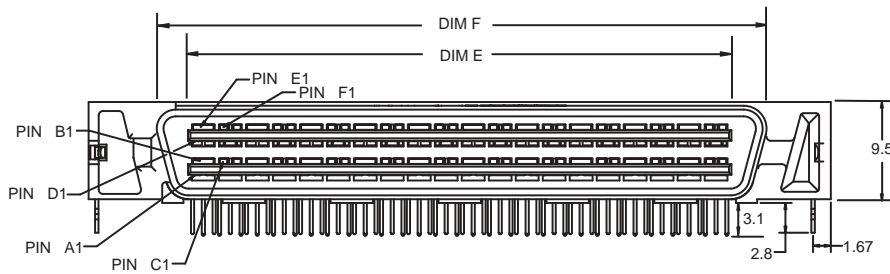
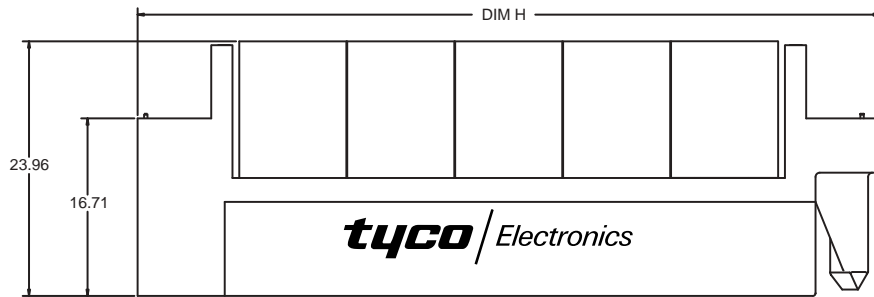

Part Number Table
Z-Dok Connector Assembly, Plug

Solder tails N	DIM H	DIM F	DIM E	DIM D	DIM C	DIM B	DIM A	Pairs	Part Numbers	Description
96	59.70	45.60	41.04	57.25	37.59	38.10	37.59	32	1367198-6	with ESD Boardlocks
72	49.54	35.44	30.88	47.09	27.43	27.94	27.43	24	1367198-5	with ESD Boardlocks
192	100.34	86.24	81.68	97.89	78.23	78.74	78.23	64	1367198-4	with ESD Boardlocks
168	90.18	76.08	71.52	87.73	68.07	68.58	68.07	56	1367198-3	with ESD Boardlocks
144	80.02	65.92	61.36	77.57	57.91	58.42	57.91	48	1367198-2	with ESD Boardlocks
120	69.86	55.76	51.20	67.41	47.75	48.26	47.75	40	1367198-1	with ESD Boardlocks
Solder tails N	DIM H	DIM F	DIM E	DIM D	DIM C	DIM B	DIM A	Pairs	Part Numbers	Description
192	100.34	86.24	81.68	97.89	78.23	78.74	78.23	64	1367444-4	with Sensing Boardlocks
168	90.18	76.08	71.52	87.73	68.07	68.58	68.07	56	1367444-3	with Sensing Boardlocks
144	80.02	65.92	61.36	77.57	57.91	58.42	57.91	48	1367444-2	with Sensing Boardlocks
120	69.86	55.76	51.20	67.41	47.75	48.26	47.75	40	1367444-1	with Sensing Boardlocks

Dimensions in mm

Z-Dok Connector Assembly, Receptacle (Continued)

Part Number 1367130-X
1367445-X

Material and Finish

Housing — Polyester, Natural

Contacts — Copper Alloy

Boardlocks — Brass

Plating

Boardlocks — 2.0µm Tin-Lead over 1.00 µm Nickel

Contacts — 0.76 µm MIN Gold in contact area, 2.54 µm Tin-Lead in termination area, over 1.27 µm MIN Nickel

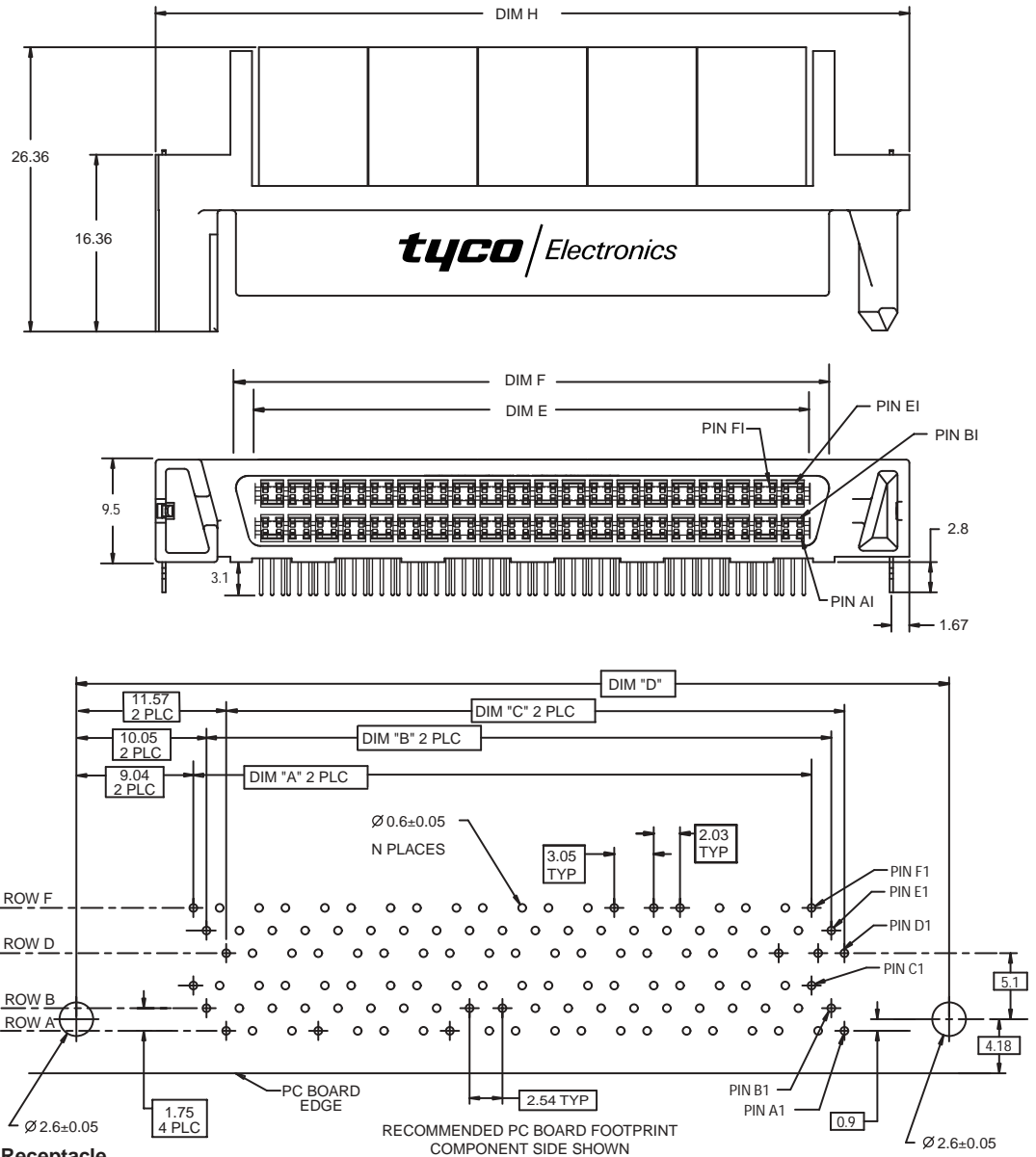

Part Number Table
Z-Dok Connector Assembly, Receptacle

Solder tails N	DIM H	DIM F	DIM E	DIM D	DIM C	DIM B	DIM A	Pairs	Part Numbers	Description
96	59.70	44.82	41.24	57.25	37.59	38.10	37.59	32	1367130-6	with ESD Boardlocks
72	49.54	34.66	31.08	47.09	27.43	27.94	27.43	24	1367130-5	with ESD Boardlocks
192	100.34	85.46	81.88	97.89	78.23	78.74	78.23	64	1367130-4	with ESD Boardlocks
168	90.18	75.30	71.72	87.73	68.07	68.58	68.07	56	1367130-3	with ESD Boardlocks
144	80.02	65.14	61.56	77.57	57.91	58.42	57.91	48	1367130-2	with ESD Boardlocks
120	69.86	54.98	51.4	67.41	47.75	48.26	47.75	40	1367130-1	with ESD Boardlocks
Solder tails N	DIM H	DIM F	DIM E	DIM D	DIM C	DIM B	DIM A	Pairs	Part Numbers	Description
192	100.34	85.46	81.88	97.89	78.23	78.74	78.23	64	1367445-4	with Sensing Boardlocks
168	90.18	75.30	71.72	87.73	68.07	68.58	68.07	56	1367445-3	with Sensing Boardlocks
144	80.02	65.14	61.56	77.57	57.91	58.42	57.91	48	1367445-2	with Sensing Boardlocks
120	69.86	54.98	51.4	67.41	47.75	48.26	47.75	40	1367445-1	with Sensing Boardlocks

Dimensions in mm

TYCO, CHAMP, Z-DOK, and AMP FAX are trademarks.